

Table of Content

Safety Instructions 2
Machine Features and Functions 3
Specifications 4
Configuration and Working Principle 5
Machine Operation 7
Machine Adjustments 8
Machine Installation 9
Machine Remove 12
Tools and Spare Parts List 13
Faults - Causes – Remedies 14
Appendices 15

Safety Instructions

1. After the machine is earthen, operator could connect the supply power to trial run.
2. Strictly following the operation procedures, add lubricating oil to each movable and frictional part, and always clean and maintain the machine.
3. Keep the gearbox full of machine oil. The new machine is required to replace the machine oil of the gearbox after one month using time, and after that replace the machine oil every half an year (generally using the machine oil #40~#50).
4. Avoid the stitcher machine stitching without wire. If happened, operator should lift up the clinch handle and clean the left wire out off the clinch. Do not leave the wire left inside the clinch and continue to stitch, avoiding affecting the machine's normal running, or even damaging the machine.
5. Make the wire from each wire spool straight and the direction is the same, in order to keep the wire reliably feeding.
6. When adjusting machine or troubleshooting, operator should cut off the power supply to avoid contingency happening.
7. Non- professional maintenance man does not allow opening the safety plate to the installing side of the electric component, avoiding being shocked.
8. When the machine is running, do not take off the organic glass safety guard.

Machine Features and Functions

The Superstitcher-10 is a semi-automatic saddle stitcher designed to stitch magazines, advertisements, instruction manuals, etc. The machine comes with two traditional style stitcher heads or two side-feed style stitcher heads.

After placing book on the saddle manually, book feeding, stitching, clinching, and conveying will be completed automatically. The features of this machine are: (1) easily understood operating process; (2) convenient maintenance procedures; (3) wide range of stitching dimension; and (4) high production capability.

Specifications

1. Machine Model: Superstitcher-10
2. Stitching Dimensions: Min. 89 mm by 127 mm
Max. 305 mm by 450 mm
3. Stitching Thickness: Max. 3 mm
4. Stitching Speed: 40 to 100 units per min
5. Normal Length of Staple's Legs: 12mm
6. Distance between Staples: Min. 46mm
7. Wire Types: #27 or #26
8. Motor Power: 0.37 kw
9. Weight of Machine: 320 kg
10. Machine Exterior Dimensions: 1313 mm (width)
2203 mm (length)
1345 mm (height)

Configuration and Working Principle

This machine consists of eight parts: (see in Figure 1)

1. Machine frame
2. Book feeding unit
3. Stitching unit
4. Insert-board book collecting unit
5. Book collecting wheels unit
6. Drive unit
7. Book output plate unit
8. Electric control unit

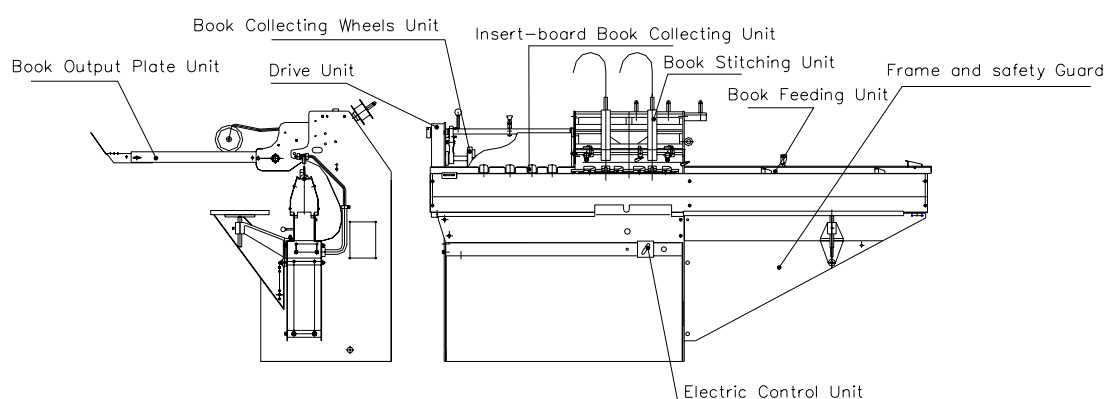

Figure 1

Turning on the power, lights up the power light and turns on the speed controller. Pressing the foot switch causes the motor to run. The front output of the motor connects to a gearbox that transfers power to a cam in the front and an eccentric wheel behind. The back output of the motor delivers power to the delivery unit. The cam consists of three parts. One runs the moving horizontal bar; one raises and lowers the clincher unit; and one raises and lowers the book insert-plates. The eccentric wheel at the back of the gearbox is connected to the bonnet assembly by an adjustable rod.

An adjustable rod connects the cam to a lever that drives the horizontal bar back and

forth. The long horizontal bar has another bar in the front which is half its length. Between the two moving bars is a stationary rod on which two metal push units slide. The long horizontal bar has a third single sided push unit. The three metal push units push the book along the stationary saddle.

The cam also drives an adjustable rod, attached to a swing lever, up and down. This action clinches the staple closed.

The third function of the cam is to drive a lever that raises and lowers the book insert-plates. When the book insert-plates move up, the rubber wheels grab the book and deliver it to the last station.

Machine Operation

Two operators operate this machine, one feeds books, and the other collects the finished books (see in Figure 2).

1. Add the lubricating oil to the moving parts, as required.
2. Add gearbox the oil (machine oil #40 to #50) to the new machine. Change after first month of operation. Then change every 6 months.
3. Check for loose screws and tighten. Run machine without book, to check if the running direction is correct and listen for abnormal sounds. Check for correct position of the two book stopping blocks above the saddle.
4. According to the dimensions of the book, first adjust the position of the bonnet rail, and then adjust the wire length for each stitcher head.
5. According to the thickness of the book to be stapled, adjust the gap between the two rows of the book collecting wheels, to make the book reliably output.
6. Rotate the speed modulation button to choose the correct speed.
7. Weave the wire through the stitcher head, place the book on the saddle, and depress the foot switch to operate.

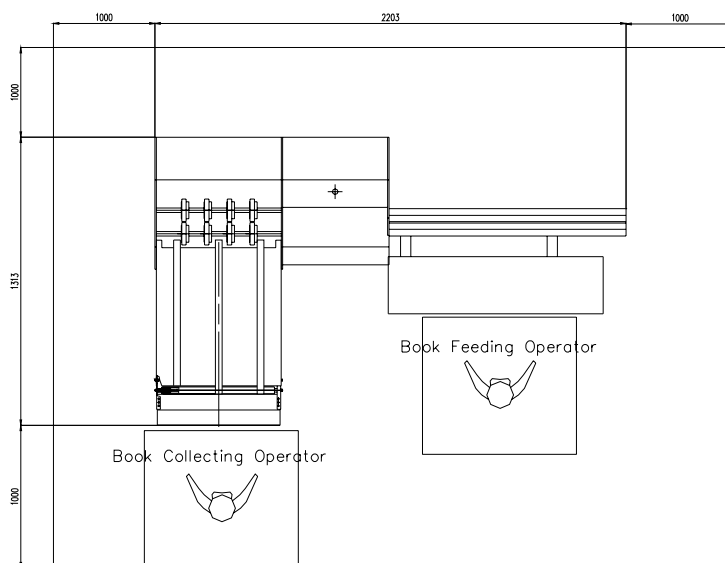

Figure 2

Machine Adjustments

1. Adjust the position of the two larger metal push units and one smaller metal push unit:

Under the machine, there is a lever that rotates on a fixed shaft and is connected to the horizontal bar at the top end. About half way up the lever an adjustable rod connects it to the cam. To adjust: loosen the locking nuts on each end of the rod and rotate the rod by way of the hole in the middle of it. After adjusting, tighten the lock nuts. The position of the push-block is set at the factory and normally does not need adjusting.

2. Adjust the height of bonnet rail:

According to the thickness of book, adjust the height of bonnet rail (see Figure 4). Adjust the bonnet rail (14) by turning the inner-hexagon screw on the top of the bonnet rail, counter clockwise to rise and clockwise to lower.

3. Adjust the position of two clincher points:

The two clincher points need to be in the proper position. If the position of the clincher points is too high, the book and parts of the machine may be damaged. If the position of clincher points is too low, the wire staple will not be clinched tightly. To adjust (see Figure 3), loosen the recessed hex screw (5) in the sliding block (4). Then loosen the two locking nuts (2) and (6), and adjust the rods length by turning the stationary nut (10) counter clockwise to raise the clincher points. After making adjustments tighten locking nuts (2) and (6), and locate sliding block (4), locking it with hex screw (5).

4. Adjust the stitcher head:

For adjustments to the stitcher head see specific operation and maintenance manual for the model of stitcher head being used.

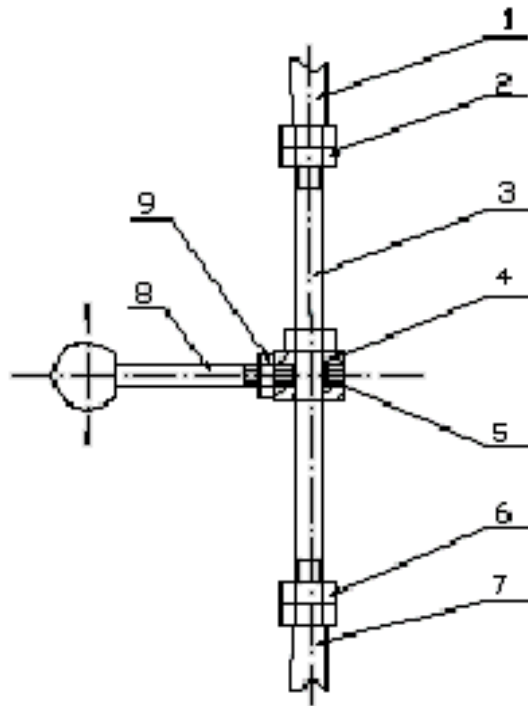

Figure 3 Clincher Adjustment Unit

- 1 upper joint bearing 2 upper lock nut 3 clincher rod
4 connecting block 5 fastening nut 6 lower lock nut
7 lower joint bearing 8 handle 9 pressure nut

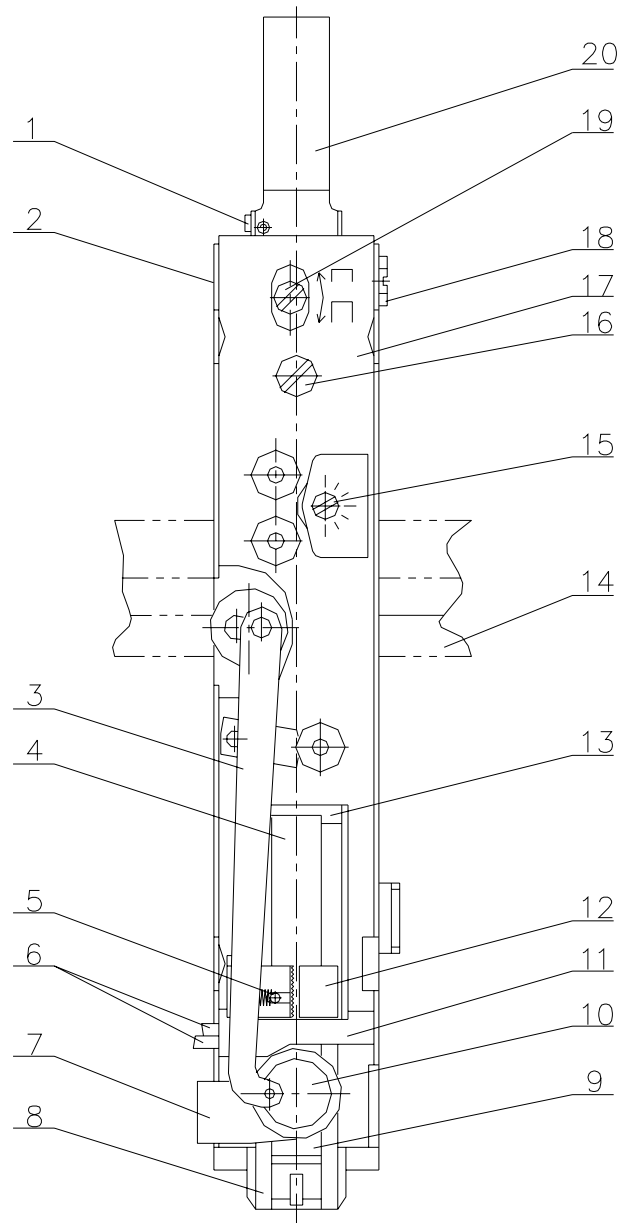

Figure 4 - Stitcher Assembly

- 1. Adjusting Screw
- 2. Stitcher Frame
- 3. Swivel Operating Spring
- 4. Driving Slide
- 5. Steel Wire Spring
- 6. Wire Cutter
- 7. Swivel Holder
- 8. Bender Bar
- 9. Supporter
- 10. Swivel
- 11. Wire Cutter Holder
- 12. Wire Clamp Block
- 13. Bender Slide
- 14. Bonnet Rail
- 15. Alignment Nut
- 16. Tightening Screw
- 17. Stitcher Plate
- 18. Tightening Screw
- 19. Wire Length Adjusting Screw
- 20. Wire Guide Spring Bracket

Machine Installation

The customer should check for damages to the packing crate upon receiving machine. Check all the items against the shipping list. If there is anything abnormal, it should be reported to DeLuxe Stitcher so that it can be corrected. Remove all surface wrapping paper and anti-rust oil. Next apply a coat of machine oil to avoid rusting.

The machine should be installed on a firm, flat concrete base to ensure that the machine is stable. Install the machine refers to Figure 5.

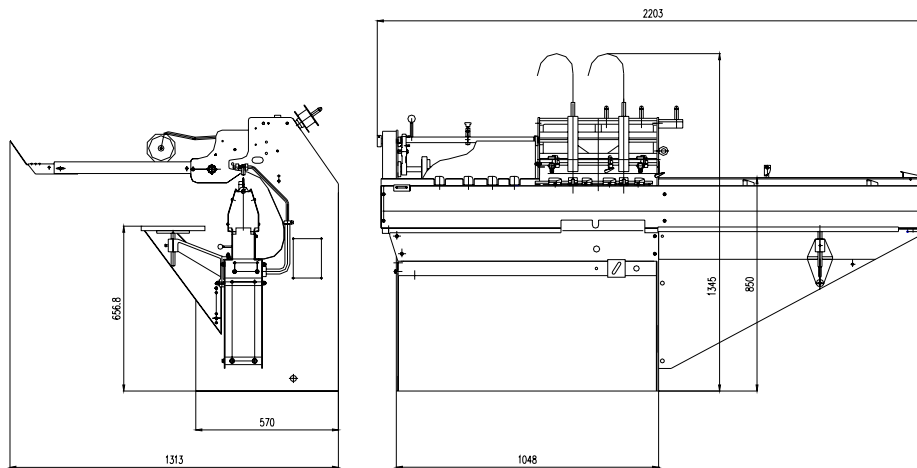

Figure 5

Machine Remove

Use the bridge crane of capacity above 1-ton, with the attached machine fittings (flying rings) to remove the machine, see in Figure 6.

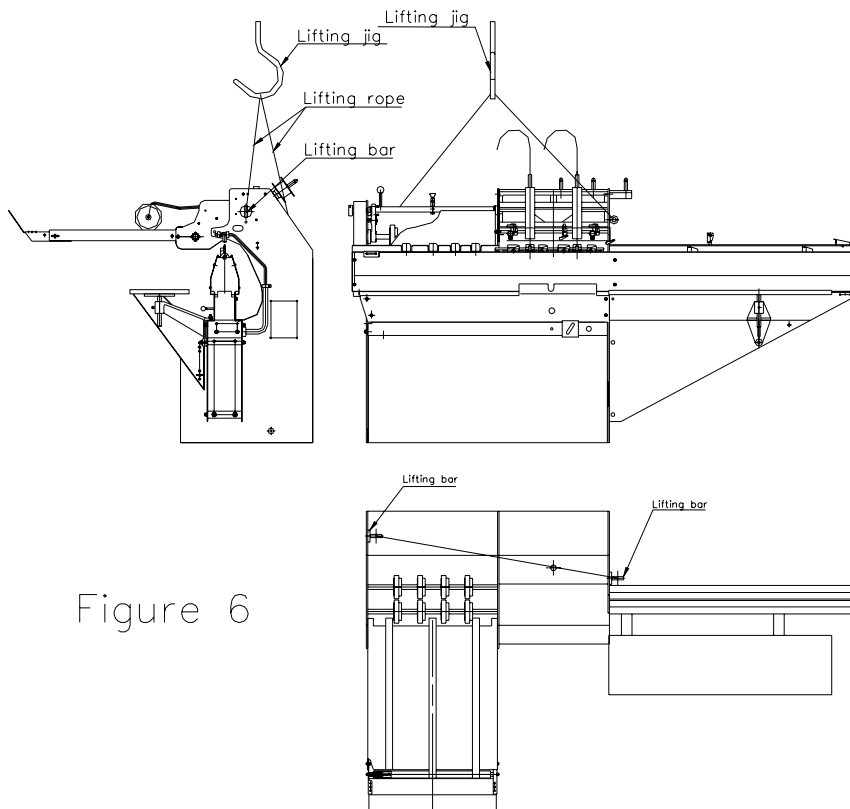

Figure 6

Tools and Spare Parts List

No.	Name& Specification	Quantity
1	Tool Box	1
2	Manual for Superstitcher-10 Stitcher	1
3	Manual for Variable Speed Controller	1
4	Manual for Stitcher Head	1
5	Side Cutting Pliers	1
6	Adjustable Wrench size 8'	1
7	'Regular Screwdriver	1
8	Phillips Screwdriver size 10"	1
9	Inner-hexagon Spanner size S 1.5 to 10	1 set
10	Inner-hexagon Spanner size S 12	1
11	Oil Can	1
12	Wooden Stopping Block OB-2-5	4
13	Spring OB-2-16	4
14	Clincher Point	2
15	Spring OB-3.3-2	2

Faults - Causes – Remedies

Faults	Causes	Remedies
No wire is feeding	<ol style="list-style-type: none"> 1. Wire spool is jammed 2. The stitcher plate is lifted too high, or the bonnet rail drops too low. 	<ol style="list-style-type: none"> 1. Straighten the wire. 2. Lower the stitcher plate, or lift the bonnet rail (see in Machine Adjustments 2).
Wire is not in shape.	Wire is contorted.	Adjust the screw to straighten the wire.
Wire is not cut off.	Cutter is worn out, or damaged.	Replace the cutter.
Stitching could not go through.	<ol style="list-style-type: none"> 1. Wire length is not enough. 2. The two stitching legs are not the same long. 3. Wire is too weak, not enough hard. 4. Cutter is worn out. 	<ol style="list-style-type: none"> 1. Increase the wire length (see in Machine Adjustments 4). 2. Adjusting (see in Machine Adjustments 5). 3. Replace the wire. 4. Replace the cutter.
Stitching is not enough fast.	<ol style="list-style-type: none"> 1. The stitcher heads are not in the same line with the clinch back plate. 2. The clincher points' rising height is not enough. 3. The clincher points are damaged. 4. Clincher supporter is damaged. 	<ol style="list-style-type: none"> 1. Re-adjust the stitcher heads or the clinch back plate, making the two ones being in the same line. 2. Lift the clincher points to the proper height (see in Machine Adjustments 3). 3. Replace the clincher points. 4. Replace the clincher supporter.

Appendices

1. Electrical Diagram

2. Electrical Wiring Diagram