

 **DeLuxe STITCHER**  
COMPANY INC.

*solving your wire stitching needs for 125 years...*

**ISP** Stitching & Bindery Products

***220V, 50Hz MODEL***

# Model B3000 Stitch'n Fold Booklet Maker

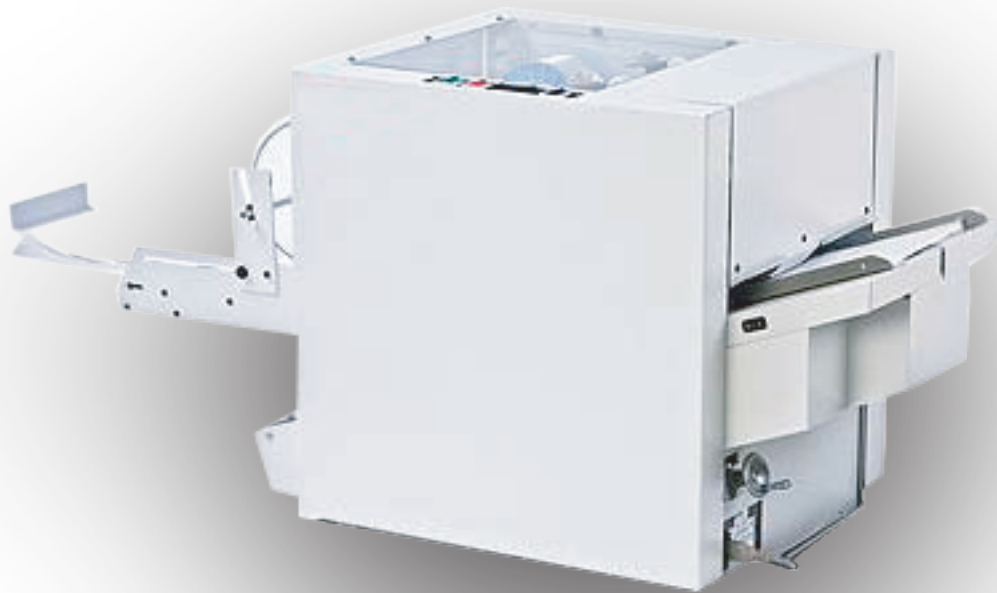

*Instructions and parts manual*

# *Stitch'n Fold*

## CONTENTS

Introduction .....	3
Specifications .....	3
Safety .....	4
Assembly Drawing .....	5
Installation .....	6
Preventive Maintenance .....	6
Control Panel .....	7
Fuses .....	7
Operation & Setup .....	8
Side Stitching .....	9
Corner Stitching .....	10
Adjustments .....	11
Clutch Shear Pin Replacement .....	13
Trouble Shooting .....	14
Exploded Drawings & Parts Lists .....	16
Electrical Schematic .....	32
Back Jog .....	33
Side/Corner Stitch Gate (Optional) .....	34
Activated Clinch (Optional) .....	35

## INTRODUCTION

Simple Operation: Just load your booklet and it is automatically jogged, stitched, folded, and discharged onto an accumulating output conveyor. Side stitching, corner stitching, and folding projects, with or without stitching, are easily accomplished.

Advanced Technology: Stitch'n Fold uses ISP's patented magnetic stitching head technology, providing the reliability and economy of wire stitching. Dual sets of folding rollers assure consistent, professional results. For safety, interlocked access guards prevent machine operation when open.

Improved Productivity: With Stitch'n Fold, you can jog, stitch, and fold more than 65,000 booklets at a maximum speed of 2,300 finished booklets per hour - without stopping to reload staples. Stitch 'n Fold's variable work thickness capacity handles from 2 sheets to a one hundred page booklet with no setup changes or adjustments.

Lower Operating Costs: The Stitch'n Fold replaces expensive preformed staples with inexpensive bookbinding wire; you save on material costs and nonproductive downtime.

## SPECIFICATIONS - MODEL: B3000

Unit Weight:	250 Pounds
Speed:	Up to 2,300 booklets per hour
Capacity:	2 to 25 sheets of 20# bond (.100" thick before folding) (100 page book)
Re-load:	65,000 booklets per spool of wire
Paper Size:	Min. 4.75" x 8.25"    Max. 12.75" x 18.5"    (also: A5 to A3)
Booklets:	4.25" x 5.5", 5.5" x 8.5", 8.5" x 11", 4.75" x 4.75 "CD", & metric sizes (All booklets with or without trim stock on one or three sides)
Stitch Space:	5.5" on 8.5" or 11" tall books    2.75" on 5.5" tall books
Counter:	Resettable 6-digit electronic counter
Folder:	Knife folder with dual folding rollers
Squaring:	Side jog plus full length tape feed
Output:	Continuous conveyor
Footprint:	16.25" x 22.5"
Dimensions:	Height 25"    Width 21"    Depth 52"
Modes:	Stitch and Fold, Stitch, Fold, Corner Stitch, Side Stitch
Electrical:	Standard outlet - 220 Volts, 50 Hz, 10 Amps    (1/4 HP)

# Stitch'n Fold

## SAFETY

### SAFETY PRECAUTIONS AND PROCEDURES

1. *Make sure electrical power is turned off before performing any adjustment or maintenance.*
2. *Keep hands, hair, tools, and clothing clear of stitching area.*
3. *Become familiar with the moving components of your machine. Keep fingers away from areas that could pinch or cut.*
4. *A well maintained machine is a safer machine. Clean and lubricate the machine at regular intervals. Check machine daily for broken or worn parts. Replace as necessary. DO NOT attempt to operate the machine if a part is broken.*
5. *See "SAFETY GUARDS" below! If you are unsure how to safely operate your Bookletmaker, contact your Service Representative.*



KEEP HANDS CLEAR OF STITCHING AREA AND ANY MOVING PARTS!

NEVER OPERATE MACHINE WITHOUT ALL GUARDS IN PLACE!

### SAFETY GUARDS

- A. Front Guard: Blocks access to the stitching heads and their point of operation. An electrical interlock keeps the machine turned off unless this hinged guard is closed. Do not stick your fingers under the front guard!
- B. Top Guard: Blocks access to mechanism that drives the stitching heads. An electrical interlock keeps the machine turned off unless this guard is closed. Do not stick your fingers under the top guard!
- C. Right Side Cover: Blocks access to mechanisms that can pinch or cut.
- D. Left Side Cover: Blocks access to dangerous electric voltage and mechanisms that can pinch or cut. Be sure to disconnect electrical power before removing this cover.
- E. Front Cover: Blocks access to dangerous electric voltage and mechanisms that can pinch or cut. Be sure to disconnect electrical power before removing this cover.
- F. Rear Cover: Blocks access to low voltage connections and mechanisms that can pinch or cut. Do not stick your fingers beyond this cover!
- G. Roller Guard: Blocks access to a pinch points. Do not stick your fingers beyond this cover!

# ASSEMBLY DRAWING

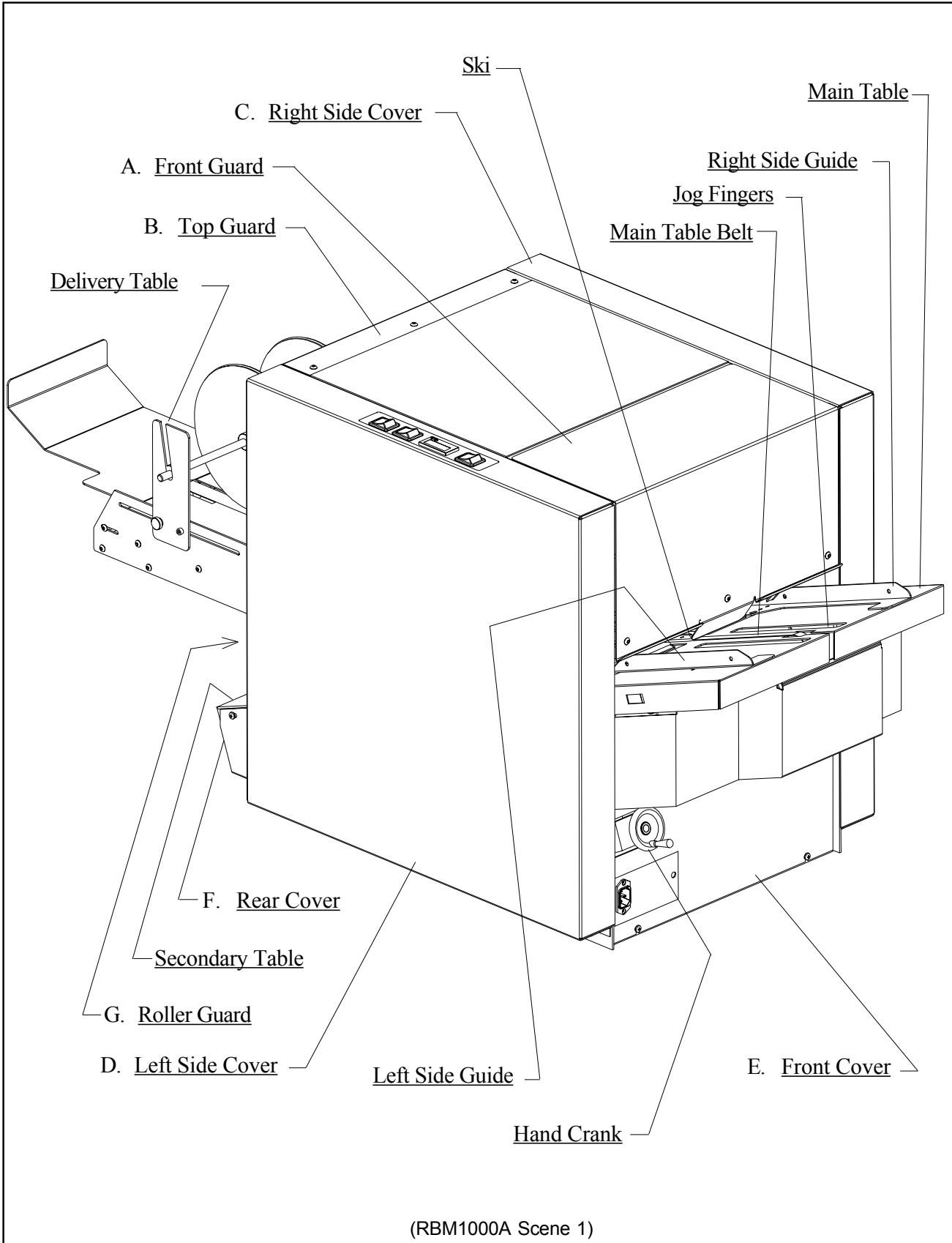

(RBM1000A Scene 1)

# Stitch'n Fold

## INSTALLATION

### BEFORE UNCRATING:

Examine the crate for visible damage. If the crate is damaged, the machine might be damaged. Notify the carrier who delivered the machine.

### UNCRATING THE MACHINE:

Carefully remove the machine from its container. Lift the machine by grasping its strong framework. Tugging on cables, covers, or other delicate components could cause damage.

Examine the machine for damages incurred during shipping. Do not install a damaged machine. Notify the carrier immediately, and be sure to get a signed copy of the Carrier Inspector's Report of the damage incurred. Your service representative will assist you in determining the cost of repairs.

### ELECTRICAL POWER:

The power cord can be plugged into any 115V, 60 Hz, 1 Phase, 15 Amp circuit. The machine draws less than 10 amps.

### LOADING & THREADING WIRE:

Use only approved stitching wire, part number 415-0225. Open the top guard to reach the wire spool studs. Remove the first retaining pin on each stud. While holding back the white brake pad, mount the coil of stitching wire so the wire comes off upward from the backside, and replace the pin.

Thread the wire upward through the large opening in the spring lever assembly, over the curved section of the lever, and through the slot in the lever. Continue to thread the wire over the large roller on top of the stitcher head, through the straightening rollers, into the check pawl, and down past the gripper. (For easier threading, temporarily turn straightening roller to "OFF" position.) Guide the wire about 1/8" into the hole in the top of the cutter.

When both heads are threaded, the machine is ready to operate. However, it will take two cycles before proper stitches are produced. See instructions in the stitching head owners manual for detailed instruction on threading wire.

## PREVENTIVE MAINTENANCE

### LUBRICATION:

Disconnect electrical power. Next, remove the front cover and both side covers.

Use SAE-20 oil to lubricate porous bronze bearings, plastic bearings, chains, and shafts.

Use 10 weight, SAE-10 oil, to lubricate the stitching heads every time a new coil of stitching wire is loaded. Clean and lubricate the magnetic rotator. Lubricate the driver bar and the bender bar latch. See stitching head owners manual for detailed lubrication instructions.

### CLEANING:

Use alcohol to clean the belts.

Use a 50-50 mixture of alcohol and water to clean the folding rollers.

## MAIN CONTROL PANEL

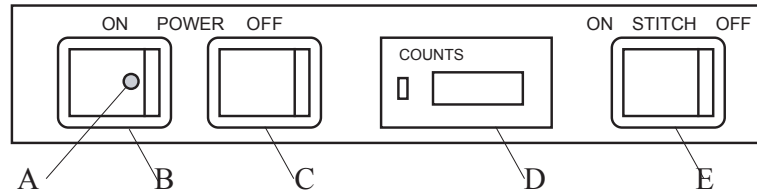

- A. Pilot Light: Glows to indicate that electrical power is turned on.
- B. Power On: Black rocker switch turns on power. Pilot glows, motor runs, and belts move.
- C. Power Off: Red rocker switch turns off power.
- D. Counter: Digital counter records the number of sets that pass through the machine. A manual reset button returns the counter to zero after each job. The reset button can be locked to prevent accidental reset.
- E. Stitch On/Off: Selector switch chooses mode of operation: "On" for stitching jobs or "Off" for folding without stitching.
- Note: Opening the front or top guards shuts off the machine. It must be restarted as above.

## FUSE PANEL

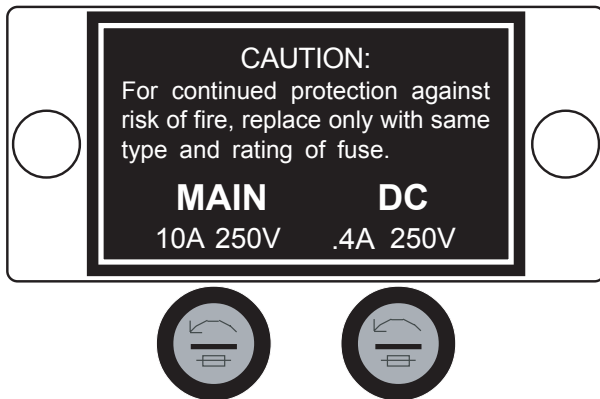

Lift open the front guard. The fuse panel is located on the left side wall. Use a small screw driver to open each fuse holder.

- A. Main Fuse: Fuse protects entire machine. If this fuse fails, power cannot be turned on. Replace with 10 amp ceramic time-delay fuse, ISP #RBM1352F.
- B. DC Fuse: Fuse protects transformer. If this fuse fails, none of the 24VDC components will operate. Replace with proper .4 amp fuse, ISP #RBM1350F.

# StitchFold

## OPERATION & SETUP

### BOOKLETMAKING

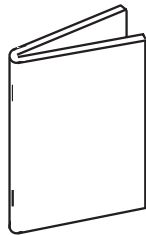

#### STITCHING HEADS:

Make sure the stitching heads are mounted in the proper positions to match the paper size. For 5.5" x 8.5" (also A5) paper, the heads must be mounted in the two positions closest to the belt on the main table. One head is mounted just to the left of the belt, and the other head is mounted just to the right of the belt. These head locations will provide a stitch spacing of 2.75". For 8.5" x 11" or 11" x 17" (also: A4 or A3) paper, each head is mounted in the second position to the left and the right of the center belt. These head locations provide 5.50" stitch spacing.

To move a stitching head to a new position, first lift open the top guard. Loosen and remove the knob/bolt from the back of the head. Pull the head forward until it comes off of the locating pin, and slide it over to the desired location. Slip the head onto the new locating pin, and be sure that the driving lug on the upper backside of the head engages the slot in the head driving bar. Replace the knob/bolt (and its washers and lockwasher), and tighten it securely.

#### PAPER WIDTH:

Adjust the side guides for paper width. For instance, if 8.5" x 11" paper is being used to make a 5.5" x 8.5" booklet, the side guides must be set for the 8.5" width. First, lift open the front guard. Loosen the thumb screw on each side guide, and slide each guide sideways until its outer edge is aligned with the 8.50" mark on the setup scale. This adjustment is critical for accurate stitch placement, so fine tune as follows. Place two sheets of paper between the side guides and slide them under the ski until they stop against the first gate. Hold the right side guide with your fingers on each side of the thumb screw

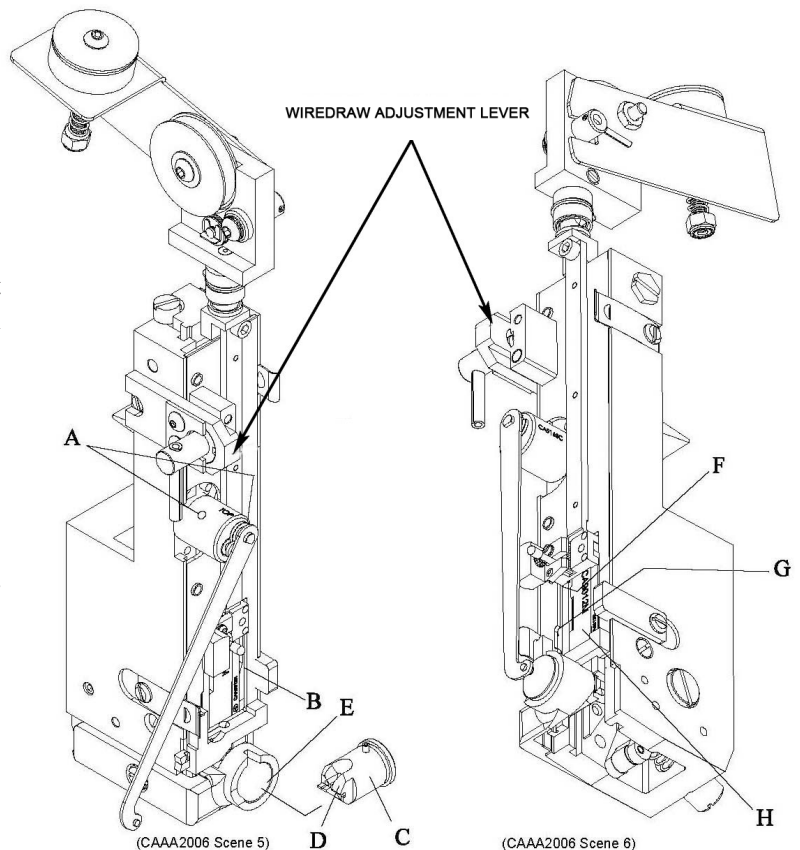

and pull it to the left until it stops at the fully jogged position. In this position, the paper must fit perfectly between the side guides. If there is a gap or the paper buckles, loosen the thumb screw on the right-hand side guide and move it in the correct direction. Recheck your side guide position until proper setting is obtained.



## PAPER LENGTH:

Adjust the gates for paper length. For instance, for 8.5" x 11" paper, the gates must be set for the 11" length. Place two sheets of paper between the side guides and slide them under the ski until they stop against the first gate. While holding the paper against the gate, turn the hand crank under the left hand side of the table until the paper is aligned with the 11" mark on the scale. (Clockwise rotation moves the paper out.) This single adjustment takes care of the stitching gate, the folding gate, and the optional back jog.

For machines equipped with the optional back jog, fine tune the hand crank adjustment as follows. Place your finger about one inch down from the top of one of the jog fingers and raise it to the point that it hits the stop. Use your other hand on the hand crank to get the two sheets firmly against the back jog finger without buckling the paper. In other words, two sheets should fit perfectly between the first gate and the raised jog fingers.

Adjust the booklet tray at the end of the delivery table to match the booklet size. Loosen the knob under the tray, and slide the tray to the proper position. Finally, adjust the position of the delivery table wheels. There are four sets of slots in the frame for positioning the shaft and wheels; choose a position that suits the booklet size. Just lift the shaft and wheels and set the ends of the shaft into the appropriate pair of slots.

## OPERATION:

Turn on power and select "STITCH ON". Square up a set of paper sheets by hand, and lay the front edge on the table between the side guides. Push until the front edge is under the ski, and then let go. The set will be automatically stitched, folded, and ejected onto the output conveyor.

## **FOLDING ONLY**

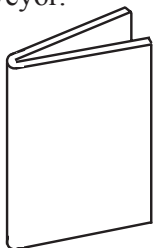

Adjust the machine for paper size according to the instructions for bookletmaking. However, the stitching heads may be left in any mounting positions. On the control panel, select "STITCH OFF".

## **SIDE STITCHING**

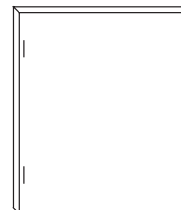

Side stitching can be done with 5.5" x 8.5" or 8.5" x 11" (also: A4 or A5) paper. In either case, mount the heads for 5.50" stitch spacing.

Lower the folding gate by pressing the toggle switch located on the secondary table. The side stitched sets will drop off the end of the secondary table unfolded. The booklet stacker assembly can be re-located to catch the finished sets.

Adjust the side guides for paper length. For instance, if 8.5" x 11" paper is being side stitched, the side guides must be set for the 11" length. Align the outer edge of each side guide with the 11" mark on the table scale.

### With Optional Side/Corner Stitch Gate:

Use thumb screw to mount gate assembly on the middle of the stitcher head mounting bar. Connect cord from gate to socket on left inside wall. Place two sheets between the side guides, and slide them under the ski until they stop against the side stitch gate. Use the hand crank to adjust the position of the back jog until the paper just fits between the gate and the raised jog fingers. If the standard fold gate returns early and causes a jam or double stitch, turn the gate timer clockwise enough to prevent the problem.

### Without Optional Side/Corner Stitch Gate:

Adjust the stitching gate for paper width. For instance, for 8.5" x 11" paper, the gate must be set for the 8.5" width. First, lift open the front guard. Place two sheets between the side guides, and slide them under the ski until they stop against the gate. Turn the knob until the trailing edge of the paper is just in front of the clinchers.

# Stitch'n Fold

## CORNER STITCHING

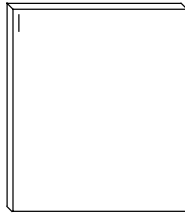

Lower the folding gate by pressing the toggle switch located on the secondary table. The side stitched sets will drop off the end of the secondary table unfolded. The booklet stacker assembly, item 6 on page 29, can be relocated to catch the finished sets.

### With Optional Side/Corner Stitch Gate:

Corner stitching can be done with 5.5" x 8.5" or 8.5" x 11" (also: A4 or A5) paper. In all cases, mount one head in the far right position. (Be sure there is a clincher, item #8 on page 20, in the far right position. If necessary, relocate the far left clincher to the far right position.) The other head may be removed or left in another position without wire. Use thumb screw to mount gate assembly on the middle of the sticher head mounting bar. See page 33 for picture of gate assembly. Connect cord from gate to socket on left inside wall.

Adjust the left side guide for paper length. For instance, if 8.5" x 11" paper is being corner stitched, the side guide must be set for the 12" length. Align the outer edge of the left side guide with the table scale as follows:

11" paper	12" mark
8.5" paper	7" mark
A4 paper	13.4" mark
A5 paper	6.5" mark

An accessory guide must be mounted on the right hand side for corner stitching. Using thumb screws and wing nuts, attach the corner stitch guide (9" long sheet metal part) to the two holes in the right side guide. See items 1, 2, and 3 on page 35.

Place two sheets between the side guides, and slide them under the ski until they stop against the corner stitch gate. Pull the right side guide left to the jogged position. If there is a gap or the paper buckles, loosen the thumb screw on the right-hand side guide and move it in the correct direction. Use the hand crank to adjust the position of the back jog until the

paper just fits between the gate and the raised jog fingers. If the standard fold gate returns early and causes a jam or double stitch, turn the gate timer clockwise enough to prevent the problem.

### Without Optional Side/Corner Stitch Gate:

Corner stitching can be done with 5.5" x 8.5" or 8.5" x 11" (also: A4 or A5) paper. In all cases, mount one head in the far left position. The other head may be removed or left in any position without wire.

Two accessory guides must be mounted on the left hand side for corner stitching. See page 35 for picture of accessories. First, adjust the standard left side guide as far as possible to the left. Using thumb screws and wing nuts, attach the corner stitch guide (9" long sheet metal part) to the two holes in the left side guide.

Next, lift open the top guard. Using two thumb screws, attach the corner stitch bar (11" long bar) to two holes in the table on the far left. The angle on the bar should face the front and middle of the machine. Adjust the left side guide until the corner stitch guide is aligned with the corner stitch bar.

Adjust the right side guide for paper length. For instance, if 8.5" x 11" paper is being corner stitched, the side guide must be set for the 11" length. Align the outer edge of the right side guide with the table scale as follows:

11" paper	11" mark
8.5" paper	6" mark
A4 paper	12.38" mark
A5 paper	6.54" mark

Adjust the stitching gate for paper width. For instance, for 8.5" x 11" paper, the gate must be set for the 8.5" width. First, lift open the front guard. Place a sheet on the table between the side guides, and slide it under the ski until it stops against the gate. Turn the knob until the trailing edge of the paper is just in front of the clinchers.

## ADJUSTMENTS

### GATE TIMER

The adjusting knob for the gate timer is located on the back of the machine's left side cover. It controls the amount of time that the stop gate is held down each cycle after the stitches have been driven into the booklet. Longer booklets need more time to get past the gate, and the next cycle cannot start until the gate has returned.

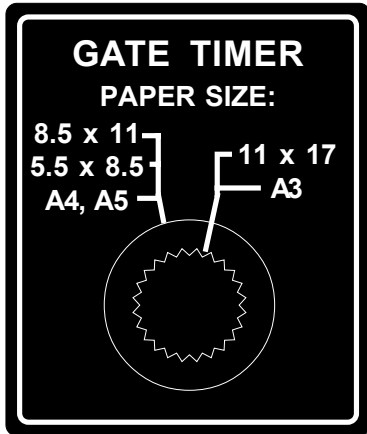

For 11" x 17" paper, set the knob as shown. The knob can be left in this position for any other paper size with feed rates up to 2,300 booklets per hour. For faster feed rates with smaller paper, turn the knob to the 8.5x11 position.

The stitch gate must be down long enough for booklet to pass over. If the gate comes up too soon, the gate limit switch could get tripped causing a double stitch. Turn the knob slightly clockwise.

If the stitch gate stays down longer than necessary and the feed rate is high, booklets will pass through the stitching station without getting stitched. Turn the knob slightly counter clockwise.

Once the adjustment is fine tuned, the knob can be calibrated by loosening its set screw and aligning the mark on the knob with the appropriate paper size.

### BOOKLET SQUARENESS

Check the finished booklet. If the stitches are properly located on the fold, but the fold is off center, adjust the gates by turning the hand crank until sets will fold precisely in half.

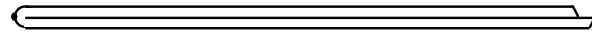

Off Center Fold

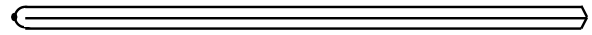

Proper Fold

**Important:** Adjust the lock nuts as described below only as a last resort. First, carefully adjust the side guides and hand crank per page 8.

If the stitches are off the fold (see below), open the booklet flat and measure to see if the stitches are centered on the length of the paper. Turn the knob until stitches are placed precisely on the center of the paper. Next, remove the rear cover and locate the two lock nuts below the back end of the secondary table. Turn both nuts equally in small increments until booklets will fold precisely on the stitches.

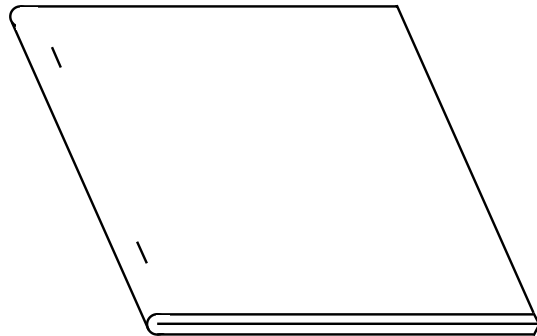

Finally, if the fold is not quite square (see below), the lock nuts can be adjusted individually.

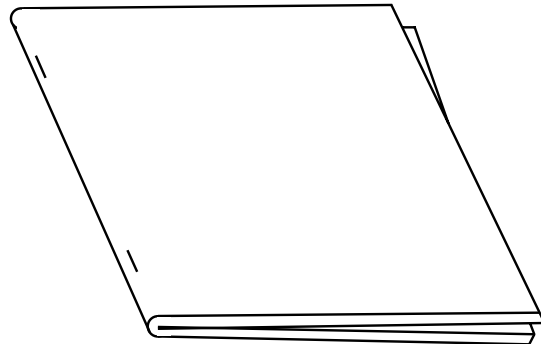

# Stitch'n Fold

## STITCHING CLUTCH

The stitching heads are controlled by a single revolution wrap spring clutch. This clutch must be adjusted to stop the stitching heads in the proper position. First disconnect electrical power. Then remove the front cover and the right side cover. The clutch is located inside the cabinet on the shaft toward the left side, and it is bronze, black, brown, and pewter in color.

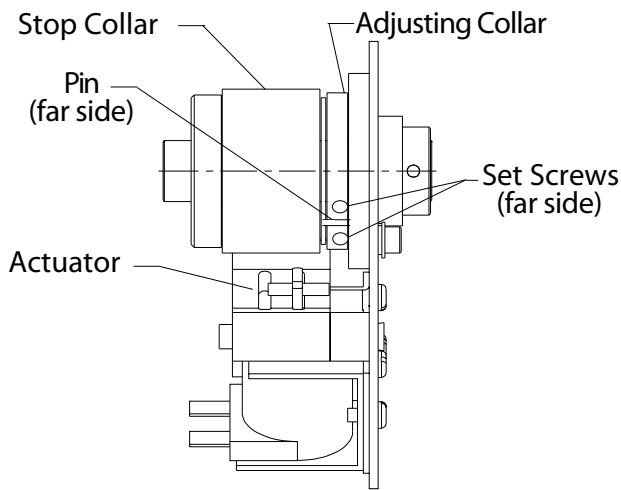

(RBM1916F Scene 1)

Clutch In Neutral Position

Remove stitching wire from the stitching heads. Trip the clutch by pushing down the brown actuator. On the right hand side of the machine, slowly turn the large spoked wheel clockwise until the first set screw in the adjusting collar is facing forward. Use a 5/64 hex wrench to loosen the set screw. Continue to turn the wheel until the second set screw is facing forward; loosen the screw.

Turn the wheel until the stop on the stop collar hits the actuator. Now turn the wheel until the proper stopping position is reached. Watch the stitching heads on the up stroke. When the bender bars reach the top of the windows in the face plates, turn the wheel slightly more. Be sure that both wire grips are still open. This is the proper stopping position. If you have gone too far, just continue to turn the wheel until you return to the proper position.

Finally, while still in the proper stopping position, trip

the clutch and turn the wheel until one of the set screws is facing forward. Carefully hold the adjusting collar so that the stop collar pin is centered in the opening in the adjusting collar. Tighten the set screw securely. Turn the wheel and trip the clutch, if necessary, until the second set screw can be tightened.

## CAM for 3LS

The cam for 3LS, which signals the stitch gate to operate, is to the right of the stitching clutch. To assure proper stitch alignment, the stitching heads should contact the work before the gate goes down. To prevent repeat stitching, the gate must pull the stitch start limit switch, 4LS, down away from the work before the clutch completes a full cycle.

First, be sure the stitching clutch has been adjusted properly. Then, trip the clutch and turn the spoked wheel clockwise until the stitcher heads just reach the clinchers. Loosen set screw on cam, and rotate the cam until it is just about to trip the limit switch. Tighten the cam in this position.

## REPLACEMENT OF SHEAR PIN ON STITCH CLUTCH

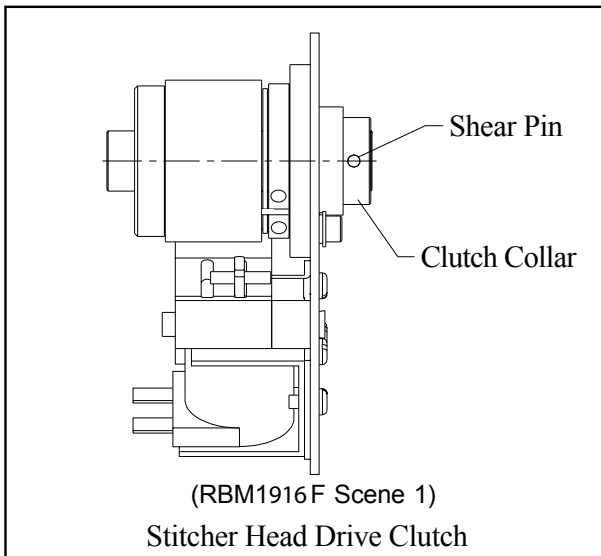

1. Unplug machine and remove front cover. The clutch is located inside the cabinet on the shaft toward the left side, and it is bronze, black, brown, and pewter in color.
2. Remove the sheared pin and replace.
3. It might be necessary to adjust the clutch per the instructions on page 12.

## REPLACEMENT OF STITCH CLUTCH

1. Unplug machine. Remove side covers and front cover.
2. See exploded view of head drive shaft on page 22. Disconnect the pull rods from both head drive cranks (#16). Remove the left side head drive crank (#16) and the right side jog actuator cam (#52) by driving out roll pin (#17).
3. Remove the bearing assembly (#18) on each side.
4. Mark the position of the side jog actuator cam (#38), then loosen both set screws and slide it to the left. If the unit has the optional activated clinch feature, loosen the set screws on its cam and also slide it to the left.
5. Mark the position of the stitch gate switch cam (#37), then loosen the set screw.
6. Remove screws (#29) from the switch and clutch bracket (#28), and gently lay the bracket down. There is no need to remove the switch wires.
7. Release the tension idlers on both drive pulley belts. And slip the belts off the pulleys to the left.
8. Move the head drive shaft (#15), and all the components connected to it, to the right and remove it.
10. Remove the pin (#32) that connects the clutch collar to the shaft, and slide all components off the shaft. Match the markings on the old shaft to the new shaft.
11. Reassemble by reversing the disassembly procedure using the new clutch coupling components.

# Stitch'n Fold

## TROUBLE SHOOTING

### PROBLEM:

### SOLUTION:

1. Unit will not turn on.	<ol style="list-style-type: none"><li>1. Plug unit into appropriate power supply.</li><li>2. If there is no green light:<ol style="list-style-type: none"><li>a. Check for proper line voltage. (115V or 220V)</li><li>b. Check the "Main" fuse.</li><li>c. Make sure front and top guards are closed.</li></ol></li></ol>
2. Book remains in stitching position.	<ol style="list-style-type: none"><li>1. Make sure motor and belt are running. If not, see problem 1.</li><li>2. Check the "DC" fuse.</li><li>3. Check the connection to the stitch gate microswitch (4LS).</li><li>4. Turn to Stitch "off" position:<ol style="list-style-type: none"><li>a. If stitch gate drops when putting a set through the machine, check connections to the stitch clutch.</li><li>b. If stitch gate doesn't drop when putting a set through, check the stitch gate microswitch (4LS).</li></ol></li></ol>
3. Book moves slowly through the machine.	<ol style="list-style-type: none"><li>1. Make sure when feeding the book that it gets under the side guides.</li><li>2. Spray furniture polish or wax on the entry and through the machine. Caution: Do not get polish or wax on paper drive belt.</li></ol>
4. Inconsistent fold.	<ol style="list-style-type: none"><li>1. Use a 50-50 mixture of rubbing alcohol and water to clean all four folding rollers.</li><li>2. Use a 50-50 mixture of rubbing alcohol and water to clean paper drive belt.</li><li>3. Check and tighten the set screws in all five sprockets that drive the folding rollers. (Three on left side; two on right.)</li><li>4. Make sure that the spring loaded folding rollers are freely springing out and back.</li><li>5. Check the folding knife for bends or waviness. Straighten or replace the knife.</li></ol>
5. Stitches are not square to book.	<ol style="list-style-type: none"><li>1. Make sure the stitch stops are square to the clinchers.</li><li>2. Make sure the side guides are square to the stops.</li></ol>
6. Stitch heads cycle and stop in the down position.	<ol style="list-style-type: none"><li>1. Adjust the stitch clutch according to page 12.</li></ol>

PROBLEM:

SOLUTION:

<p>7. Stitch heads won't cycle.</p>	<ol style="list-style-type: none"> <li>1. Make sure that Stitch on/off switch is in "on" position.</li> <li>2. Check stitch clutch solenoid to see if it is activating when triggered by the stitch gate microswitch (4LS):             <ol style="list-style-type: none"> <li>a. If solenoid is activating and heads still don't cycle, check stitch clutch shear pin. See page 13.</li> <li>b. If solenoid is not activating, check the stitch clutch connections. There should be 24VDC to the solenoid when it is triggered by 4LS. If the solenoid fails to activate when 24VDC is applied, replace the stitch clutch.</li> </ol> </li> </ol>
<p>8. Loud banging/clicking noise when stitch heads cycle.</p>	<ol style="list-style-type: none"> <li>1. Lubricate head per the "External Lubrication Sheet" provided with the stitch heads. (Lubrication instructions also appear in the EZ Thread Owners Manual.) <b>Pay special attention to the rotator lubrication.</b></li> </ol>
<p>9. Double stitch.</p>	<ol style="list-style-type: none"> <li>1. Check stitch gate timer setting; see instructions on page 11. The gate should stay down until the tail end of the book clears the stitch gate. Otherwise, turn clockwise.</li> <li>2. Adjust cam for 3LS according to page 12.</li> <li>3. Check for sluggish operation of stitch gate. If there is binding or the return spring is too strong, the gate will fail to pull the stitch start limit switch, 4LS, away from the paper causing repeat stitching.</li> <li>4. Adjust the stitch clutch according to page 12.</li> </ol>
<p>10. Booklet folded but not stitched.</p>	<ol style="list-style-type: none"> <li>1. Make sure that Stitch on/off switch is in "on" position.</li> <li>2. Check that you are not feeding the books so fast that the gate has not come back up to receive the next book in time. In that case, adjust stitch gate timer setting per instructions on page 11.</li> </ol>

# Stitch'n Fold

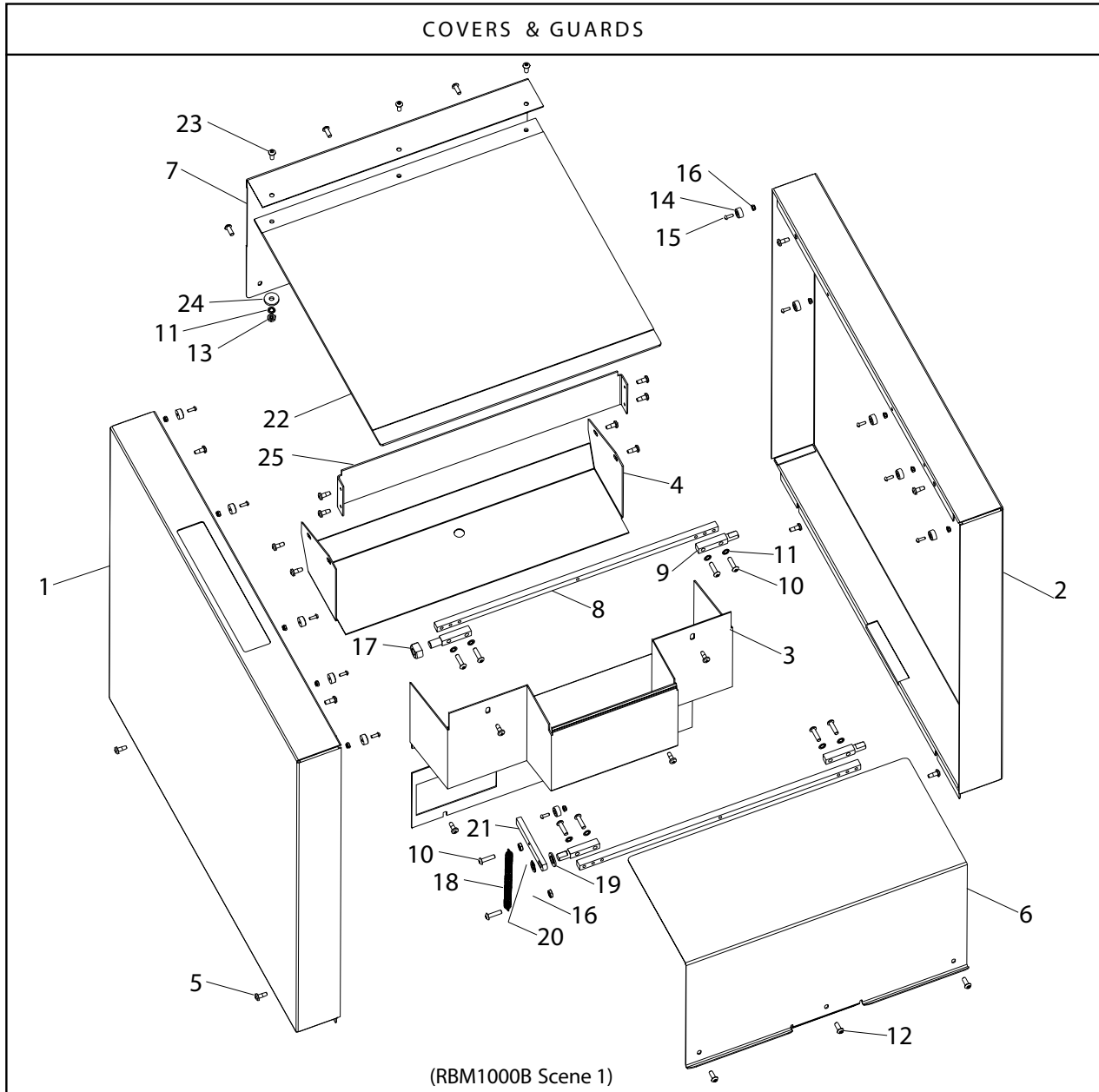

Index Number	Part Number	Part Name	Number Required	Index Number	Part Number	Part Name	Number Required
1	RBM1575F	LH Cover	1	14	RBM1316F	Rubber Bumper	11
2	RBM1574F	RH Cover	1	15	D27396F	Round Hd Scr 5-40 x 3/8	11
3	RBM1697F	Front Cover	1	16	D27398F	Elastic Lock Nut #5-40	11
4	RBM1676A	Back Cover	1	17	RBM1686F	Interlock Cam	1
5	RBM1324F	Pan Hd Scr 10-32 x 1/2	20	18	RBM1694F	Extension Spring	1
6	RBM1602F	Front Guard	1	19	CB2125	Nylon Washer	1
7	RBM1850F	Top Guard	1	20	RBM1586F	Retaining Ring	1
8	RBM1607F	Guard Bracket	2	21	RBM1688F	Spring Arm	1
9	RBM1687F	Guard Hinge	4	22	RBM1771F	Top Guard Window	1
10	CG26C	Button Hd Scr 10-32 x 3/4	10	23	CG26A	Button Hd Scr 10-32 x 1/2	3
11	CB988	Lockwasher #10	11	24	RBM1790F	Steel/Rubber Washer	3
12	CG26	Button Hd Scr 10-32 x 3/8	6	25	RBM1849F	Roller Guard	1
13	CB278	Nut #10-32	6				



## FRAME ASSEMBLY

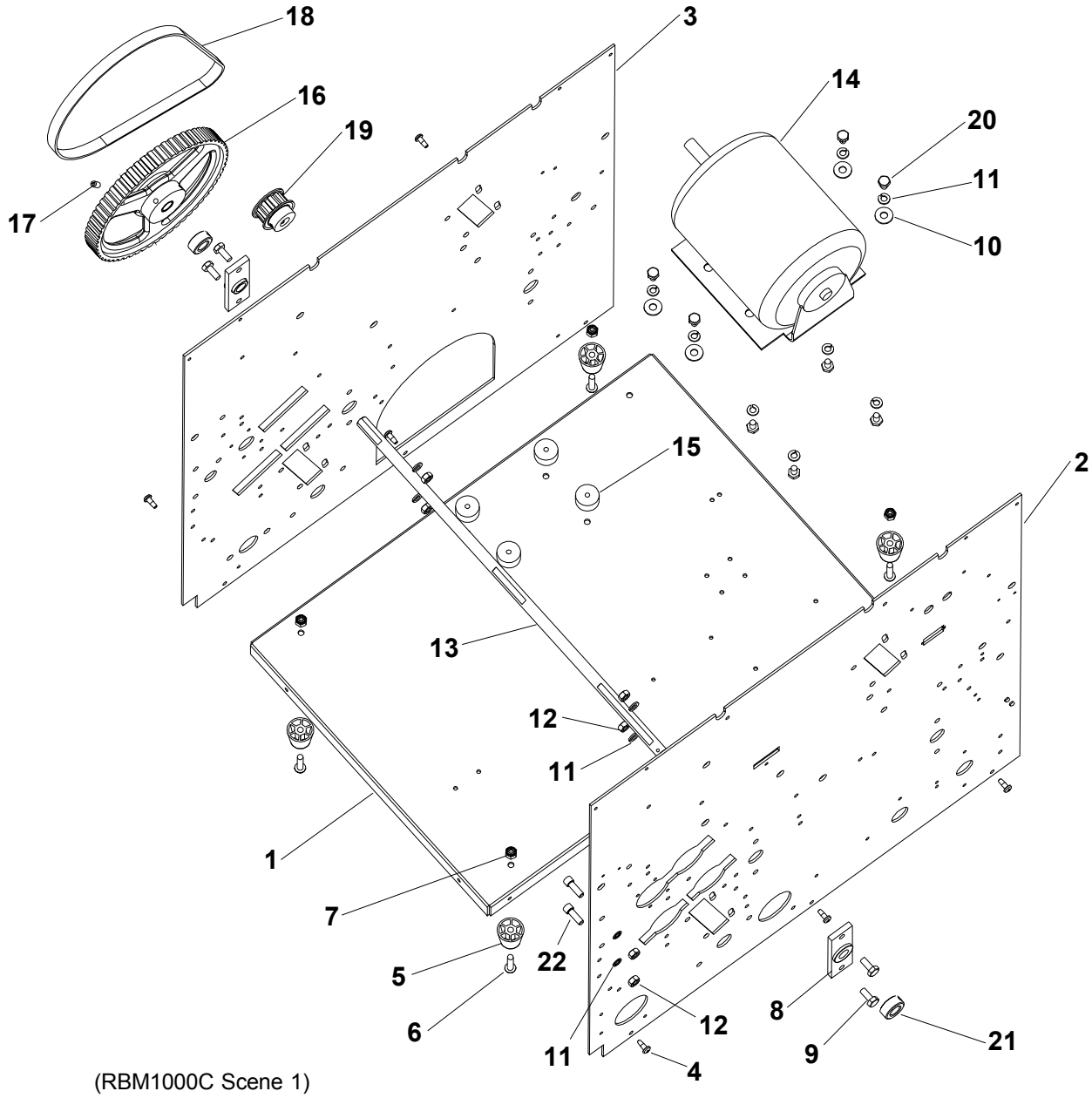

(RBM1000C Scene 1)

Index	Part	Part Name	Number	Index	Part	Part Name	Number
1	RBM1529F	Frame Bottom	1	13	RBM1543F	Tape Drive Shaft (also item 22 page 21)	1
2	RBM1566F	LH Side Frame	1	14	RBM1201F	Motor (also item 29 page 32)	1
3	RBM1565F	RH Side Frame	1	15	RBM1301F	Motor Mount	4
4	RBM1324F	Pan Hd Scr 10-32 x 1/2	6	16	RBM1046A	Tape Drive Pulley Assy	1
5	RBM1202F	Bumper Foot	4	17	CB59	Set Scr 1/4-20 x 1/2	2
6	RBM1252F	Rd Hd Scr 1/4-20 x 1	4	18	RBM1209F	Motor Belt	1
7	CB860C	Elastic Stop Nut 1/4-20	4	19	RBM1208F	Motor Pulley	1
8	RBM1480A	Bearing Assy	2	20	RBM1382F	Hex Hd Scr 1/4-20 x 3/8	8
9	CB487	Hex Hd Scr 1/4-20 x 3/4	4	21	RBM1657F	Collar	2
10	CB718	Washer 1/4	4	22	CB51	Screw, .250-20 x .750 Soc. Hd.2	2
11	RBM1519F	Lockwasher 1/4	14				
12	CB493	Nut 1/4-20	6				

# Stitch'n Fold

## HEAD DRIVE ASSEMBLY

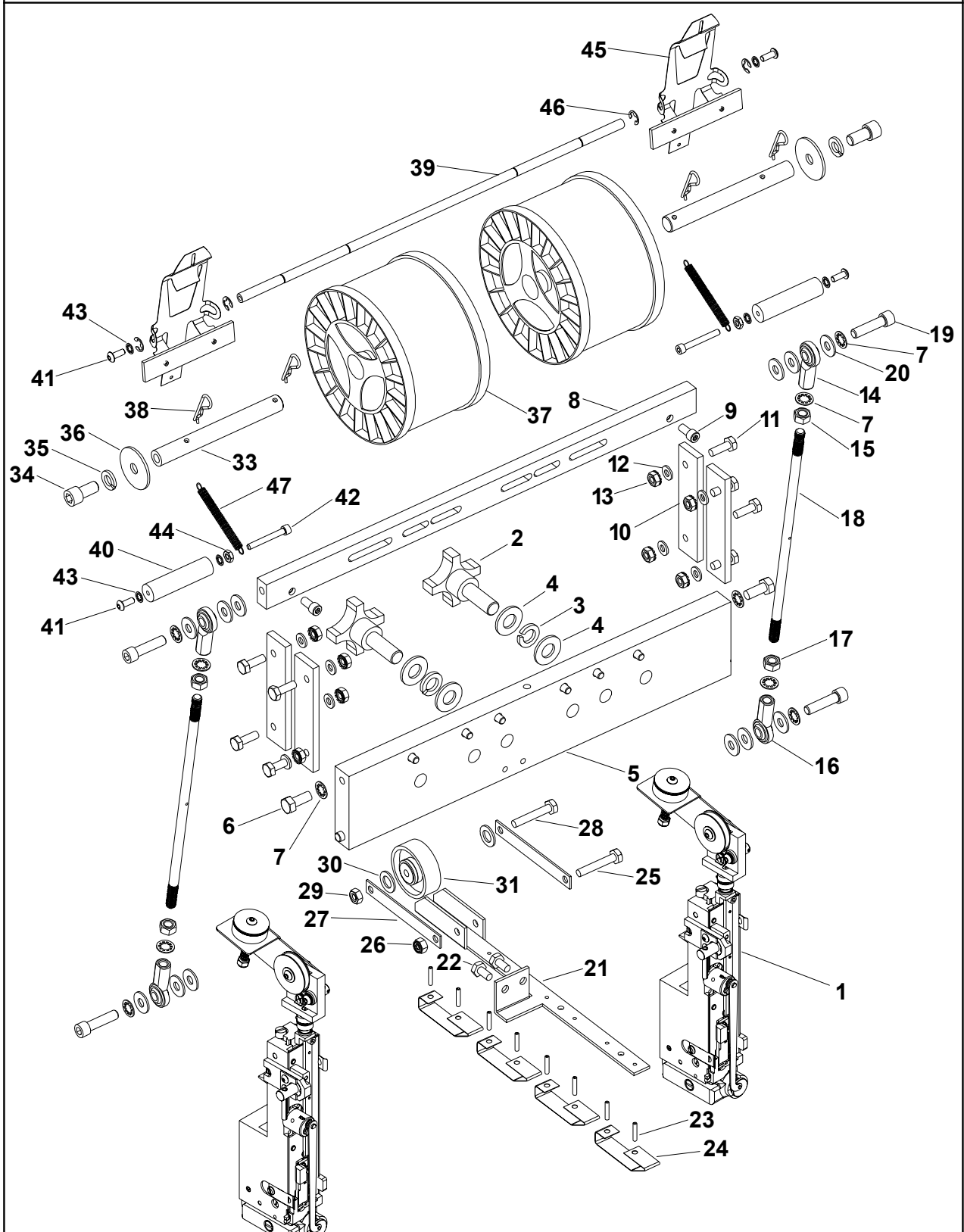

(RBM1000D Scene 1)

Index	Part	Part Name	Number
1	CAA2006W	EZ Thread Stitcher Head	2
2	RBM1321A	Knob Assy	2
3	CB734	Lockwasher 1/2	2
4	RBM1630F	Washer 1/2	4
5	RBM1530A	Head Support Bar Assy	1
6	CB606	Hex Hd Scr 5/16-18 x 3/4	2
7	CB895	Lockwasher 5/16	10
8	RBM1550F	Head Actuating Bar	1
9	CB325	Soc Hd Scr 1/4-20 x 1/2	2
10	RBM1564F	Head Drive Wear Strip	4
11	CB487	Hex Hd Scr 1/4-20 x 3/4	8
12	CB806	Washer	8
13	RBM1617F	Keps Nut 1/4-20	8
14	RBM1220F	RH Rod End	2
15	CB418	RH Nut 5/16-24	2
16	RBM1221F	LH Rod End	2
17	RBM1262F	LH Nut 5/16-24	2
18	RBM1037F	Head Connecting Rod	2
19	CB110A	Soc Hd Scr 5/16-18 x 1 1/4	4
20	CB718	Washer	12
21	RBM1659F	Ski Bracket	1
22	CK31	Hex Hd Scr 1/4-20 x 1/2	2
23	CA9028A	Roll Pin 1/8 x 11/16	8
24	RBM1391F	Paper Ski	4
25	CB764	Hex Hd Scr 1/4-20 x 1 1/2	1
26	CB860C	Elastic Stop Nut 1/4-20	1
27	RBM1660F	Roller Arm	2
28	RBM1361F	Plastic Screw 1/4-20 x 1 1/2	1
29	CB411	Plastic Nut 1/4-20	1
30	CB806	Washer	2
31	CB1247A	Roller	1
33	RBM1642F	Wire Spool Stud	2
34	CB314A	Soc Hd Scr 3/8-16 x 3/4	2
35	CB889	Lockwasher 3/8	2
36	CA46	Washer	2
37	415-0225	Stitching Wire (Two Spools)	1
38	CK176	Hairpin	4
39	RBM1644F	Shaft	1
40	RBM1656F	Spacer	2
41	CG26A	Button Hd Scr 10-32 x 1/2	4
42	MF337	Soc Hd Scr 10-32 X 1 1/2	2
43	CB988	Lockwasher #10	6
44	CB278	Nut 10-32	2
45	RBM1646A	Spring Lever Assy	2
46	RBM1645F	E-Ring	4
47	CK250	Spring	2

# Stitch'n Fold

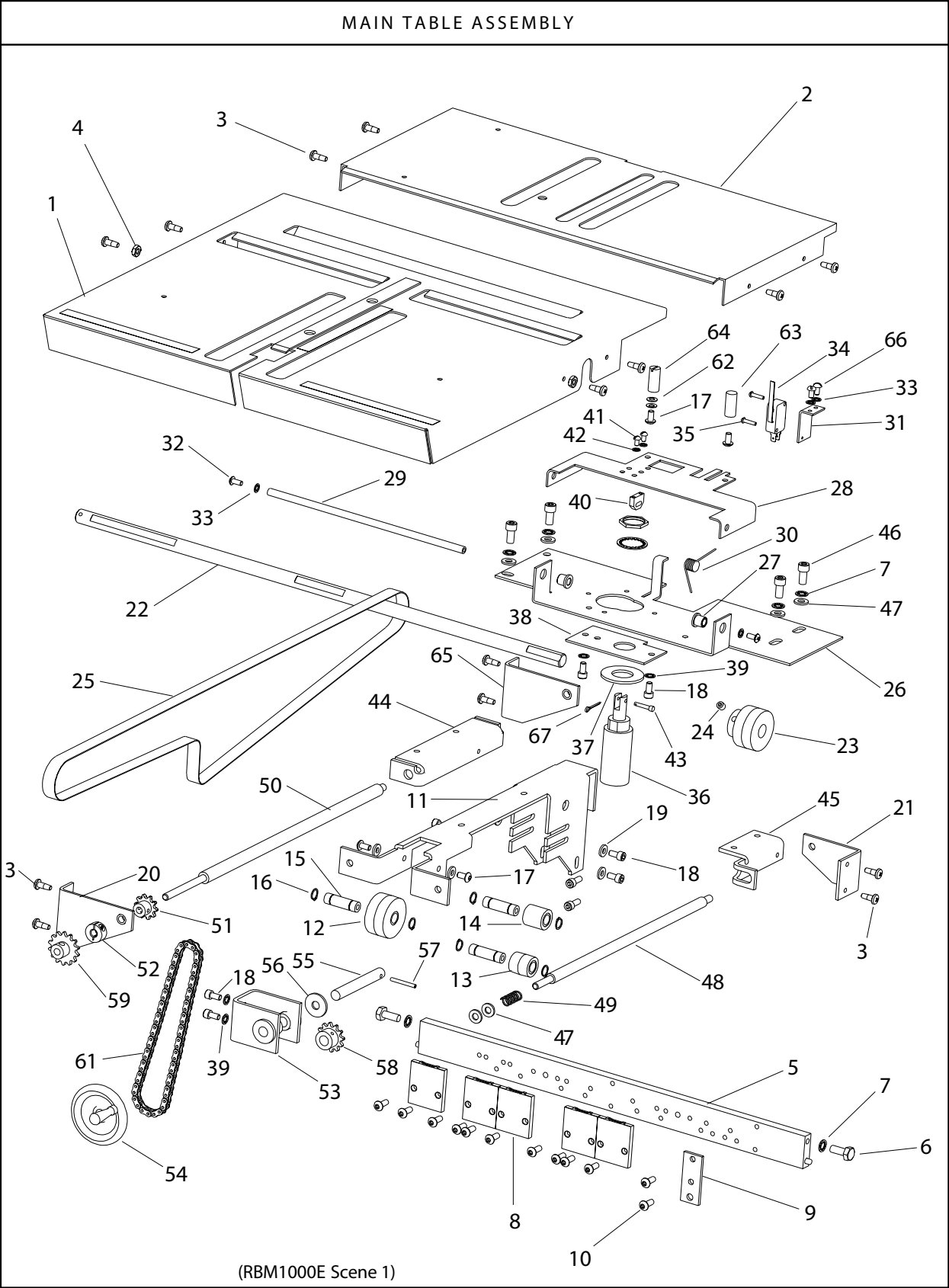

Index	Part	Part Name	Number	Index	Part	Part Name	Number
1	RBM1528A	Main Table	1	34	RBM1310C	Microswitch	1
2	RBM1615F	Gate Table	1			(also item 31 page 32)	
3	RBM1324F	Pan Hd Scr 10-32 x 1/2	14	35	RBM1327F	Rd Hd Scr 4-40 x 1/2	2
4	CB278	Nut 10-32	4	36	RBM1234F	Solenoid (also item 49 page 32)	1
5	RBM1551A	Clincher Bar	1				
6	CB487A	Hex Hd Scr 1/4-20 x 5/8	2	37	CE17	Washer	1
7	RBM1519F	Lockwasher 1/4	6	38	RBM1507F	Back Up Plate	1
8	CT9086X	Clincher	5	39	CB988	Lockwasher #10	6
9	RBM1024F	RH Front Bracket	1	40	RBM1272F	Solenoid Pivot Bracket	1
10	CG26A	Button Hd Scr 10-32 x 1/2	12	41	CB287	Rd Hd Scr 6-32 x 3/16	2
11	RBM1600F	Center Pulley Bracket	1	42	CK50	Lockwasher #6	2
12	RBM1627A	Center Belt Pulley Assy	1	43	RBM1720F	Pin	1
13	RBM1101A	Crowned Idler Assy	1	44	RBM1750F	LH Guide Bracket	1
14	RBM1340A	Flat Idler Assy	1	45	RBM1751F	RH Guide Block	1
15	RBM1614F	Idler Shaft	3	46	CB325	Soc Hd Scr 1/4-20 x 1/2	4
16	CB837B	Retaining Ring 3/8	6	47	CB806	Washer 1/4	6
17	CG26	Button Hd Scr 10-32 x 3/8	6	48	RBM1547F	Stop Carriage Rod	1
18	CB651F	Soc Hd Scr 10-32 x 3/8	8	49	RBM1667F	Spring	1
19	CB1262	Washer #10	8	50	RBM1591F	Stop Carriage Screw	1
20	RBM1777A	Front LH Bracket	1	51	RBM1269F	Sprocket 10T	1
21	RBM1548F	RH Rear Bracket	1	52	RBM1311F	Split Collar	1
22	RBM1543F	Tape Drive Shaft	1	53	RBM1635A	Bracket Assy	1
23	RBM1096F	Table Drive Pulley	1	54	RBM1775F	Hand Crank	1
24	CB141	Set Scr 1/4-20 x 1/4	1	55	RBM1780F	Hand Crank Shaft	1
25	RBM1536F	Table Belt	1	56	CB175	Washer 3/8	1
26	RBM1482F	Stop Carriage	1	57	RBM1760F	Roll Pin 18 x 1	1
27	RBM1249F	Plastic Bearing	2	58	RBM1781F	Sprocket 12T	1
28	RBM1783F	Stop Platform	1	59	RBM1782F	Sprocket 14T	1
29	RBM1313F	Gate Shaft	1		CA118	Set Scr 1/4-20 x 3/16	1
30	RBM1666F	Torsion Spring	1	61	RBM1670F	Chain - 62L	1
31	RBM1506F	Switch Bracket	1	62	CL44A	Spring Washer	2
32	CG26N	Button Hd Scr 8-32 x 3/8	2	63	RBM1769F	Paper Stop	1
33	CB988A	Lockwasher #8	4	64	RBM1770F	Eccentric Paper Stop	1
				65	RBM1549A	Rear LH Bracket	1
				66	CB112	Rd Hd Scr 8-32 x 5/16	2
				67	CB451	Cotter Pin	1

# Stitch'n Fold

## HEAD DRIVE SHAFT ASSEMBLY

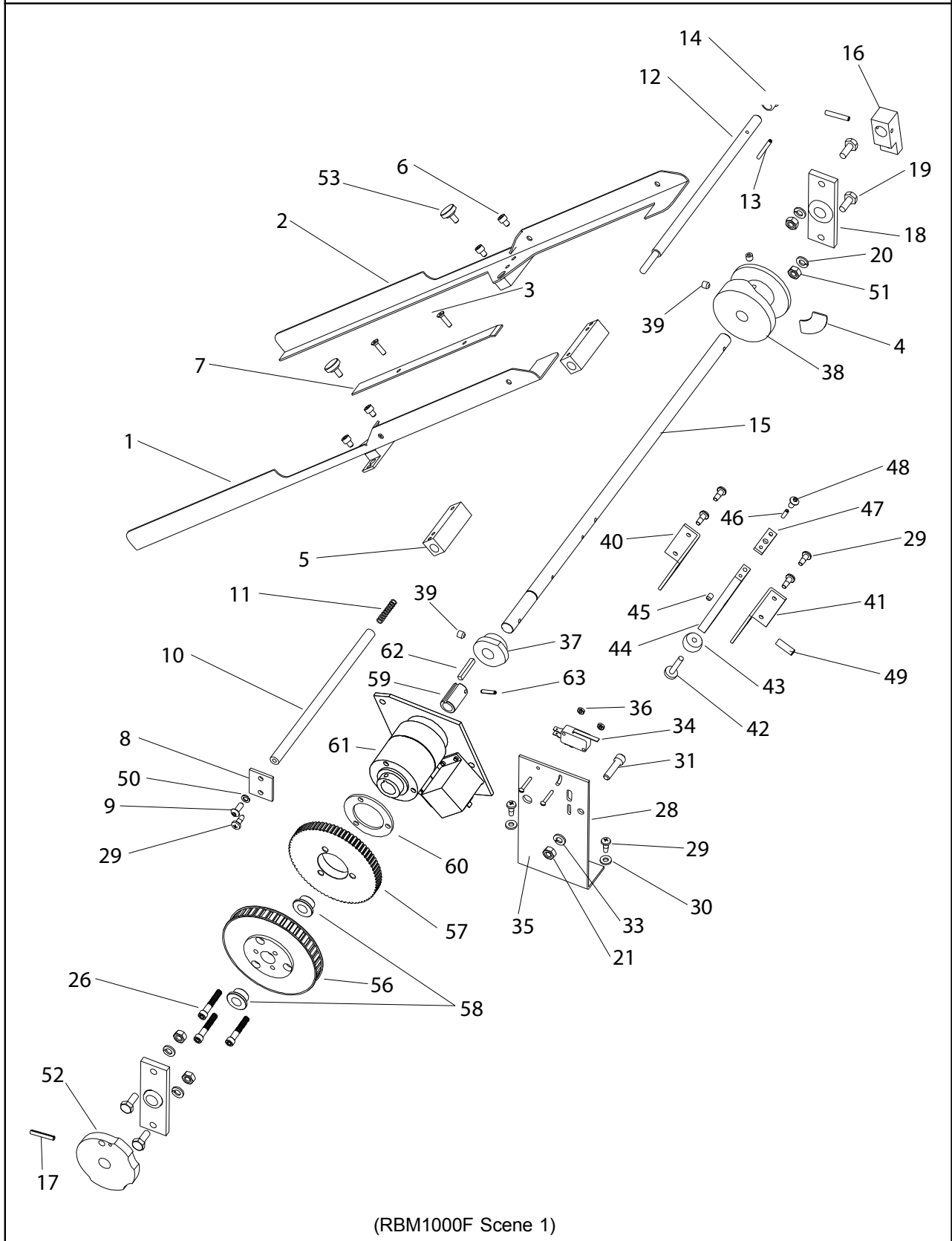

(RBM1000F Scene 1)

Index Number	Part Number	Part Name	Number Required	Index Number	Part Number	Part Name	Number Required
1	RBM1629A	LH Side Guide	1	35	RBM1328F	Rd Hd Scr 4-40 x 3/4	2
2	RBM1628A	RH Side Guide	1	36	CG13	Nut 4-40	2
3	RBM1329F	Flat Hd Scr 8-32 x 5/8	2	37	RBM1126F	Switch Cam	1
4	RBM1789F	Cam Shim	1	38	RBM1559F	Actuator Cam	1
5	RBM1623F	Side Guide Bracket	2	39	CB141	Set Screw 1/4-20 x 1/4	3
6	D34080F	Soc Hd Scr 10-32 x 1/4	4	40	RBM1091F	LH Bracket	1
7	RBM1622F	Belt Bed	1	41	RBM1090F	RH Bracket	1
8	RBM1651F	Plate	1	42	RBM1086F	Roller Stud	1
9	CG26A	Button Hd Scr 10-32 x 1/2	1	43	RBM1085F	Roller	1
10	RBM1540F	Stationary Guide Shaft	1	44	RBM1084F	Actuator Bar	1
11	RBM1229F	Spring	1	45	D22872F	Set Scr 10-32 x 1/4	1
12	RBM1539F	Moveable Guide Shaft	1	46	CB835P	Roll Pin	1
13	CB835G	Roll Pin	1	47	RBM1087F	Actuator Bar Extension	1
14	RBM1250F	Plastic Bearing	1	48	CG26	Button Hd Scr 10-32 x 3/8	1
15	RBM1542F	Head Drive Shaft	1	49	CB1201	Dowel Pin	1
16	RBM1637F	Head Drive Crank	1	50	CB988	Lockwasher #10	1
17	D37751F	Roll Pin 5/32 x 1	2	51	CB493	Nut 1/4-20	4
18	RBM1480A	Bearing Assy	2	52	RBM1638F	Cam	1
19	CB487	Hex Hd Scr 1/4-20 x 3/4	4	53	CGG44B	Thumb Scr Knob Assy	2
20	RBM1519F	Lockwasher 1/4	4	55**	CB837E	Retaining Ring, 1/2	1
21	CB493	Nut 1/4-20	1	56	RBM1910F	Pulley, CB6 Clutch	1
21*	CB125	Nut 3/8-16	1	57	RBM1909F	Pulley, Knife Drive	1
26**	CB651B	Soc Hd Scr 10-32 x 3/4	3	58	RBM1912F	Bearing, Flanged	2
26	CB629C	Soc Hd Scr 1/4-20 x 1 1/2	3	59	RBM1913F	Shaft Adapter	1
28	RBM1596F	Switch & Clutch Bracket	1	60	RBM1911F	Pulley Spacer	1
29	RBM1324F	Pan Hd Scr 10-32 x 1/2	7	61	RBM1916F	Clutch CB6	1
30	CB1262	Washer #10	2	62	RBM1917F	Key 3/16 x 1-1/4	1
31	CB629A	Soc Hd Scr 1/4-20 x 1	1	63	UB3532.34	Roll Pin	1
31*	CB314	Soc Hd Scr 3/8-16 x 1	1				
33	CB371A	Lockwasher 1/4	1				
33*	CB889	Lockwasher 3/8	1				
34	RBM1225F	Microwitch (3LS) (also item 30 page 32)	1				

\* Parts marked with asterisk are for machines equipped with Hi-Torque Clutch for Loop Stitch Heads or four head applications.

\*\*For use on machines with serial numbers 2650 and up. When replacing the discontinued RBM1748F clutch on a model B2000 prior to serial #2650, order update kit CBBB3000J7.

**Below listed part numbers are for reference from previous B1000 and B2000 model machines:**

22	RBM1047F	Head Drive Pulley	1
22*	RBM1794F	Head Drive Pulley	1
23**	RBM1900F	Bearing	1
23*	RBM1796F	Bearing	1
24**	RBM1902F	Knife Drive Pulley	1
24*	RBM1793F	Knife Drive Pulley	1
25**	RBM1901F	Clutch (also item 54 page 32)	1
25*	RBM1792F	Clutch (also item 54 page 32)	1
27	CB988	Lockwasher #10	3
27*	RBM1519F	Lockwasher 1/4	3
32	RBM1760F	Roll Pin 1/8 x 1	1
32*	RBM1797F	Roll Pin 5/32 x 1 1/4	1
54**	CB284B	Dowel Pin, 3/16 x 1	3

## ROLLERS & KNIFE ASSEMBLY

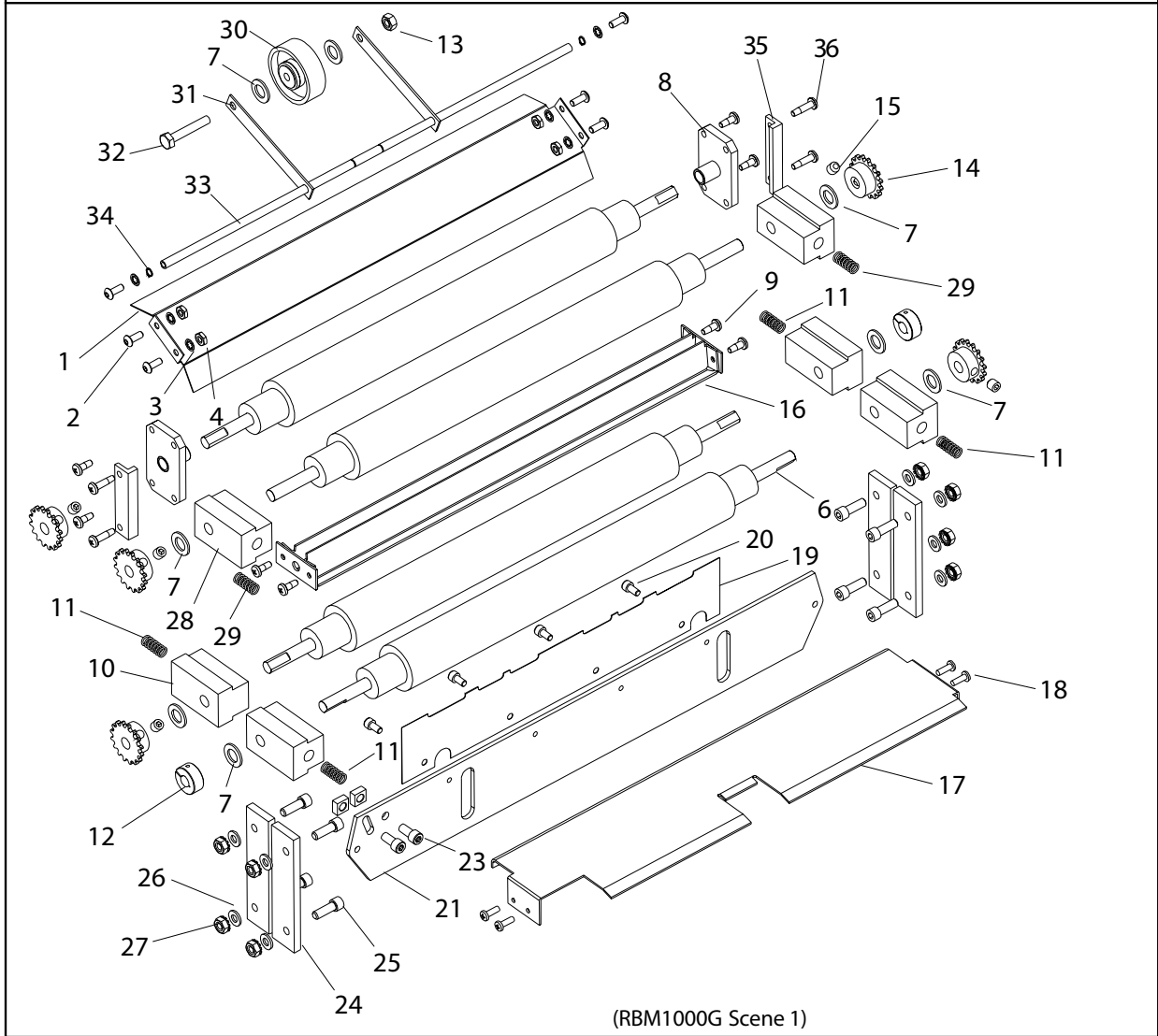

(RBM1000G Scene 1)

Index Number	Part Number	Part Name	Number Required	Index Number	Part Number	Part Name	Number Required
1	RBM1535F	Book Deflector	1	19	RBM1621F	Folding Knife	1
2	CG26A	Button Hd Scr 10-32 x 1/2	4	20	CB651F	Soc Hd Scr 10-32 x 3/8	4
3	CB278	Nut 10-32	4	21	RBM1534F	Knife Support	1
4	CB988	Lockwasher #10	4	22	RBM1616F	Square Nut 1/4-20	2
5	-----	-----	--	23	CB325	Soc Hd Scr 1/4-20 x 1/2	2
6	RBM1553A	Lower Folding Roll Assy	4	24	RBM1564F	Head Drive Wear Strip	4
7	CB2125	Nylon Washer 7/16 (3/4 O.D.)	8	25	CB487	Hex Hd Scr 1/4-20 x 3/4	8
8	RBM1613A	Bearing Block Assy	2	26	CB806	Washer	8
9	RBM1324F	Pan Hd Scr 10-32 x 1/2	8	27	RBM1617F	Keeps Nut 1/4-20	8
10	RBM1589F	Bearing Housing	4	28	RBM1800F	Bearing Housing	2
11	RBM1667F	Folding Roll Spring	4	29	RBM1801F	Folding Roll Spring	2
12	RBM1312F	Split Collar	2	30	CB1247A	Roller Wheel	1
13	CB493	Nut, .250-20 Hex.	1	31	RBM1660F	Roller Arm	2
14	RBM1216F	Folding Sprocket (also item 36 page 26)	5	32	RBM1361F	Screw, .250-20 x 1.5 PVC Hex.	1
15	RBM1399F	Set Screw 5/16-18 x 5/16	5	33	RBM1851F	Shaft	1
16	RBM1568A	Book Guide Assy	1	34	CB837C	Retaining Ring, ø.25 Ext.	2
17	RBM1533F	Spacer Table	1	*35	RBM1876F	Spacer, Roller	2
18	RBM1323F	Pan Hd Scr 8-32 x 1/2	4	*36	RBM1334F	Pan Hd Scr 10-32 x 3/4	4

\*Used on BookletMakers serial # 2350 and up



## KNIFE SHAFT ASSEMBLY

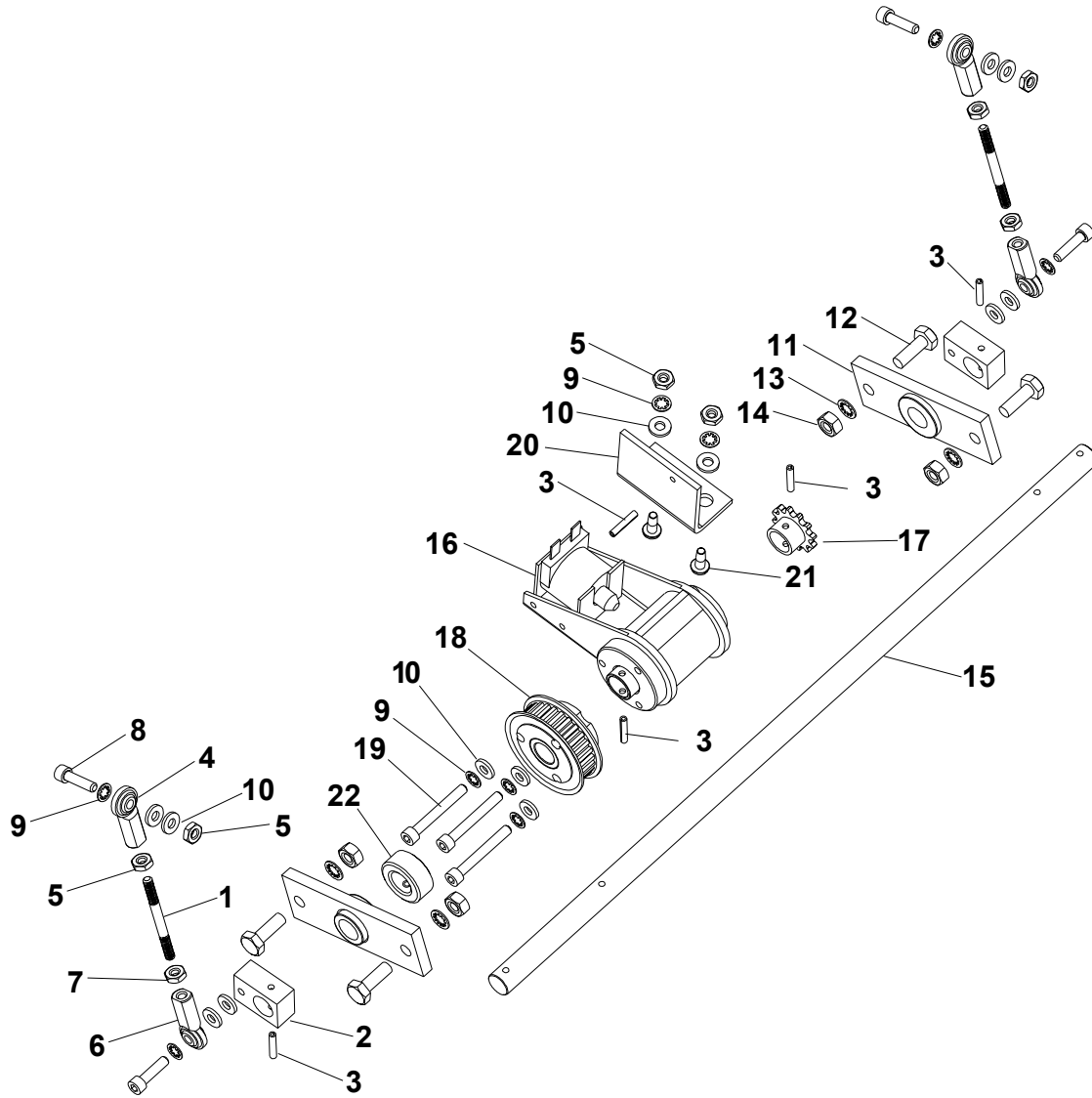

(RBM1000H Scene 1)

Index	Part	Part Name	Number	Index	Part	Part Name	Number
1	RBM1036F	Knife Connection Rod	2	12	CB487	Hex Hd Scr 1/4-20 x 3/4	4
2	RBM1040F	Knife Drive Crank	2	13	RBM1519F	Lockwasher 1/4	4
3	CA9028A	Roll Pin 1/8 x 11/16	5	14	CB493	Nut 1/4-20	4
4	RBM1222F	RH Rod End	2	15	RBM1541F	Knife Drive Shaft	1
5	CB278	RH Nut 10-32	6	16	RBM1227F	Clutch (also item 52 page 32)	1
6	RBM1223F	LH Rod End	2	17	RBM1217F	Sprocket-12T	1
7	RBM1263F	LH Nut 10-32	2	18	RBM1206A	Pulley Assy	1
8	CB651B	Soc Hd Scr 10-32 x 3/4	4	19	CB651D	Soc Hd Scr 10-32 x 1 1/4	3
9	CB988	Lockwasher #10	9	20	RBM1597F	Knife Clutch Bracket	1
10	CB1262	Washer #10	13	21	RBM1324F	Pan Hd Scr 10-32 x 1/2	2
11	RBM1480A	Bearing Assy	2	22	RBM1657F	Collar	1

# Stitch'n Fold

## BELTS & CHAINS ASSEMBLY

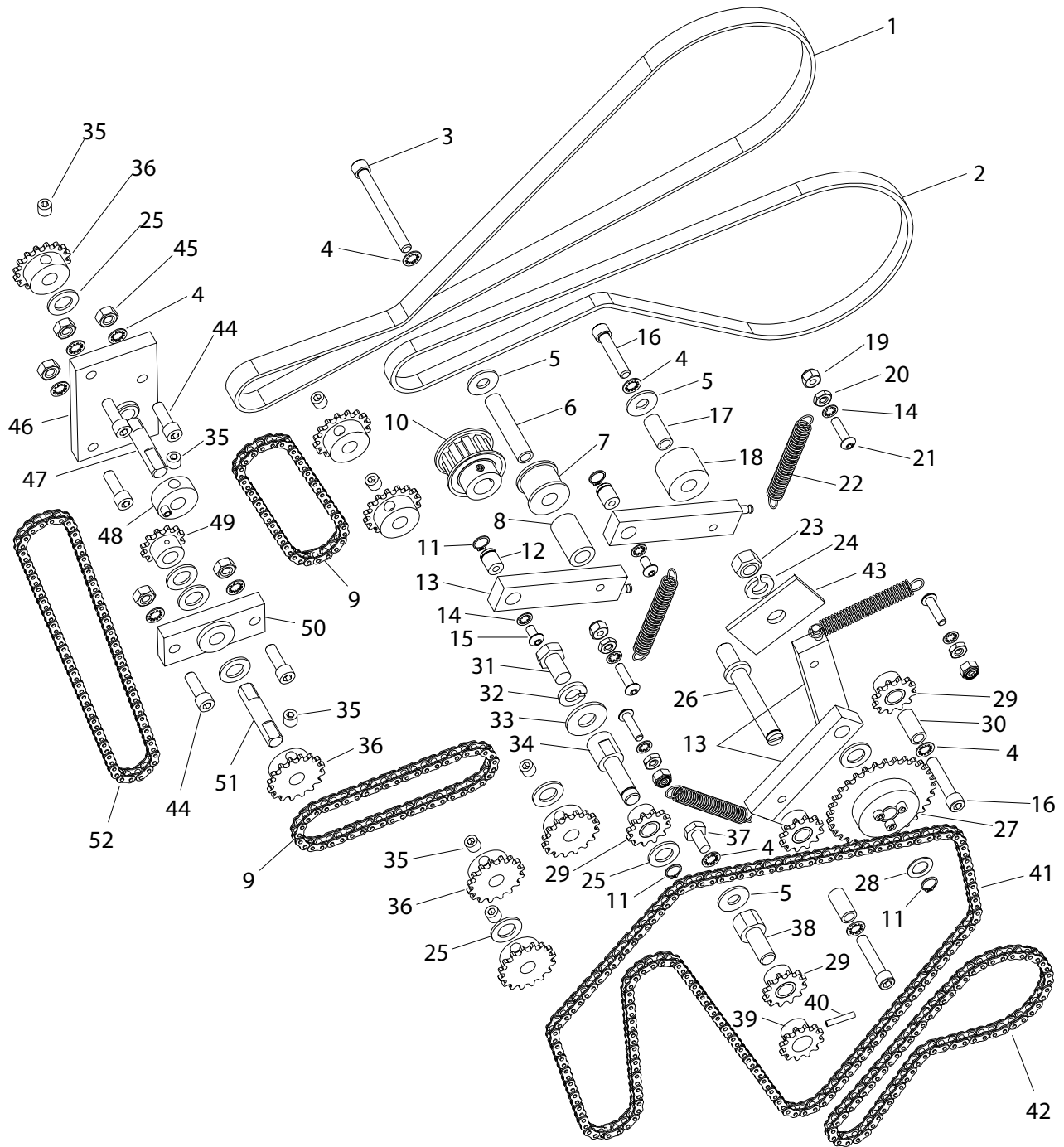

(RBM1000J Scene 1)

Index	Part	Part Name	Number
1	RBM1211F	Timing Belt 3/8" Wide	1
2	RBM1210F	Timing Belt 1/2" Wide	1
3	D44958F	Soc Hd Scr 1/4-20 x 2 1/2	1
4	RBM1519F	Lockwasher 1/4	10
5	CB718	Washer	3
6	RBM1294F	Knife Idler Shaft	1
7	RBM1291F	Idler Roll	1
8	RBM1295F	Idler Spacer	1
9	RBM1673F	Chain - 44L	2
10	RBM1207F	Reducer Pulley 10 Teeth	1
11	CB837B	Retaining Ring 3/8	4
12	RBM1045F	Idler Bracket Stud	2
13	RBM1044A	Idler Bracket Assy	4
14	CB988	Lockwasher #10	6
15	CG26	Button Hd Scr 10-32 x 3/8	2
16	CB629B	Soc Hd Scr 1/4-20 x 1 1/4	3
17	RBM1293F	Stitcher Idler Shaft	1
18	RBM1360F	Idler Roll	1
19	CB860B	Elastic Stop Nut 10-32	4
20	CB278	Nut 10-32	4
21	CG26C	Button Hd Scr 10-32 x 3/4	4
22	RBM1231F	Idler Spring	4
23	D30541F	Nut 3/8-16	1
24	CB889	Lockwasher 3/8	1
25	CB2125	Nylon Washer 7/16 (3/4 O.D.)	8
26	RBM1288F	Sprocket Stud	1
27	RBM1286A	Dual Sprocket Assy	1
28	CT32	Washer	1
29	RBM1218A	Idler Sprocket Assy	4
30	RBM1289F	Idler Stud	2
31	CB328	Hex Hd Scr 3/8-16 x 5/8	1
32	CB889	Washer 3/8	1
33	CB179	Lockwasher	1
34	RBM1662F	Idler Shaft	1
35	RBM1399F	Set Screw 5/16-18 x 5/16	8
36	RBM1216F	Folding Sprocket	7
37	CK31	Hex Hd Scr 1/4-20 x 1/2	1
38	RBM1633F	Idler Shaft (mount on bearing)	1
39	RBM1217F	Drive Sprocket	1
40	CA9028A	Roll Pin 1/8 x 11/16	1
41	RBM1674F	Chain - 156L	1
42	RBM1670F	Chain - 62L	1
43	RBM1807F	Stud Backup Plate	1
44	CB51	Screw, .250-20 x .75 Soc. Hd.	5
45	CB493	Nut, .250 -20 Hex.	5
46	RBM1822A	Bearing Block Assy.	1
47	RBM1824F	Index Shaft	1
48	RBM1826A	Index Collar Assy.	1
49	RBM1781F	Sprocket-12T	1
50	RBM1812A	Bearing Block Assy.	1
51	RBM1848F	Idler Shaft	1
52	RBM1874F	Chain-88L	1

# Stitch'n Fold

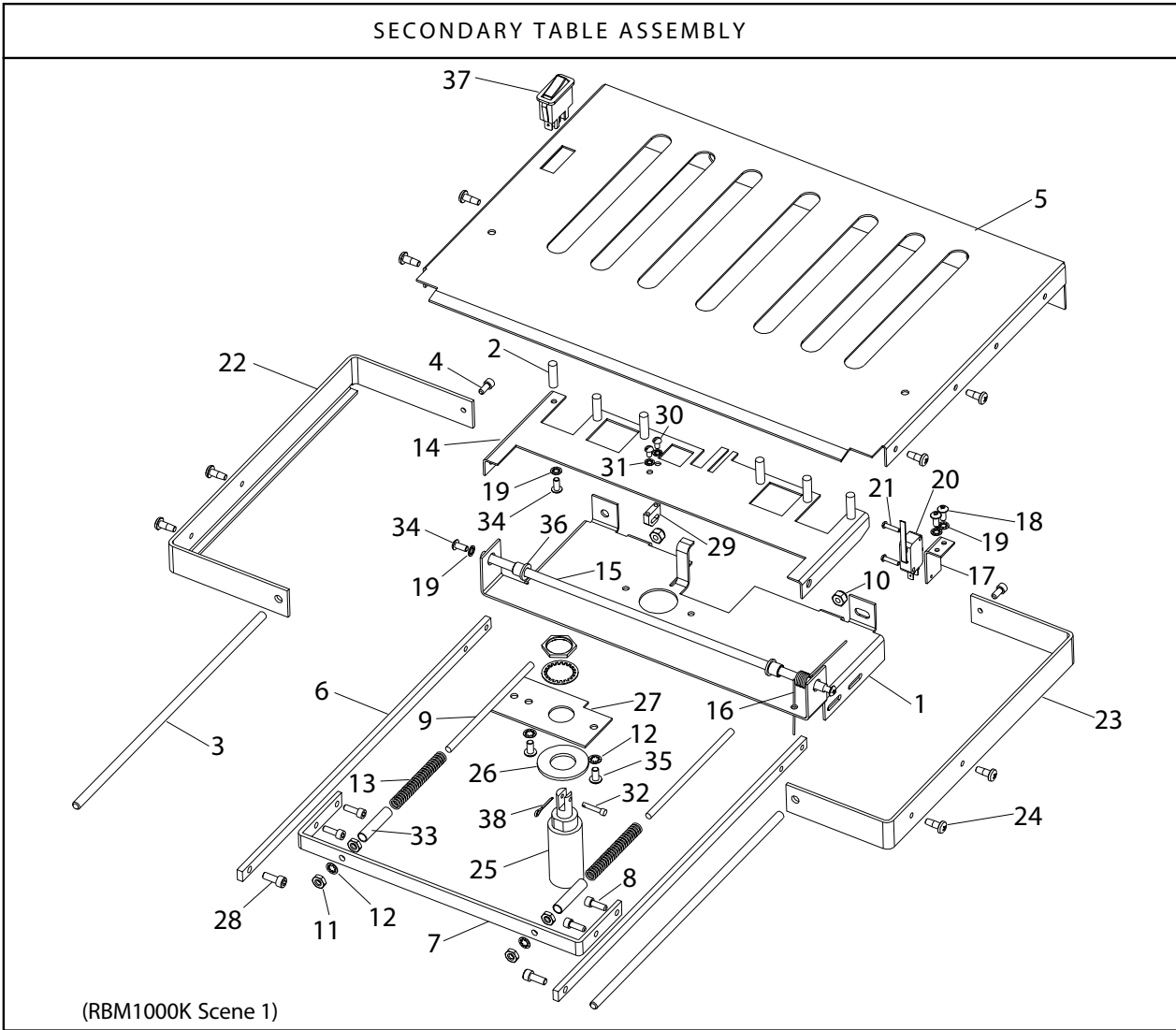

Index Number	Part Number	Part Name	Number Required	Index Number	Part Number	Part Name	Number Required
1	RBM1784F	Stop Carriage	1	21	RBM1327F	Rd Hd Scr 4-40 x 1/2	2
2	RBM1767	Paper Stop	6	22	RBM1560F	U-Bracket LH	1
3	RBM1588F	Guide Rod	2	23	RBM1561F	U-Bracket RH	1
4	D30676F	Soc Hd Cap Scr 8-32 x 3/8	2	24	RBM1324F	Pan Hd Scr 10-32 x 1/2	8
5	RBM1786F	Secondary Table	1	25	RBM1567F	Solenoid (also page 30)	1
6	RBM1556F	Adjusting Bar	2	26	CE17	Washer	1
7	RBM1664F	Stud Bracket	1	27	RBM1507F	Back Up Plate	1
8	RBM1765F	Soc Hd Cap Scr 8-32 x 3/4	4	28	CB651F	Soc Hd Cap Scr 10-32 x 3/8	2
9	RBM1665F	Adjusting Stud	2	(screws connect item 6 to items 44 & 45 page 20)			
10	CB860B	Elastic Lock Nut 10-32	2	29	RBM1272F	Solenoid Pivot Bracket	1
11	CB278	Nut 10-32	4	30	CB287	Rd Hd Scr 6-32 x 3/16	2
12	CB988	Lockwasher #10	4	31	CK50	Lockwasher #6	2
13	RBM1305F	Spring	2	32	RBM1720F	Pin	1
14	RBM1766F	Stop Platform	1	33	RBM1685F	Spacer	2
15	RBM1785F	Gate Shaft	1	34	CG26N	Button Hd Scr 8-32 x 3/8	8
16	RBM1518F	Torsion Spring	1	35	CG26	Button Hd Scr 10-32 x 3/8	2
17	RBM1506F	Switch Bracket	1	36	RBM1249F	Plastic Bearing	2
18	CB112	Round Hd Scr 8-32 x 5/16	2	37	CB285R2	Fold On/Off Sw	1
19	CB988A	Lockwasher #8	8	(also item 54 page 32)			
20	RBM1310C	Microswitch	1	38	CB451	Cotter Pin	1
		(also item 31 page 32)					

## DELIVERY TABLE ASSEMBLY

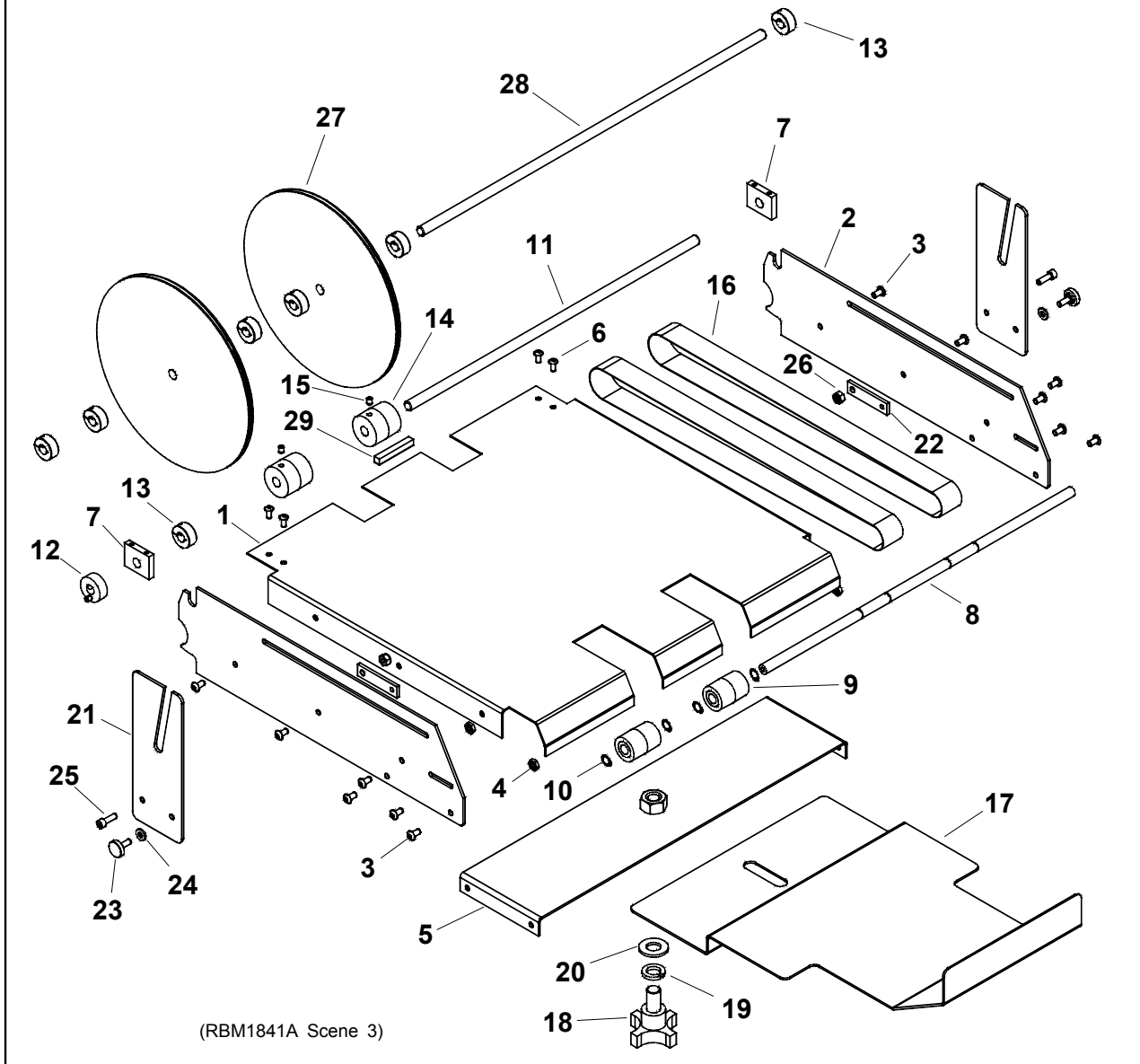

Index	Part	Part Name	Number	Index	Part	Part Name	Number
1	RBM1841F	Conveyor Table	1	16	RBM1846F	Conveyor Belt	2
2	RBM1838F	Conveyor Bracket	2	17	RBM1840F	Delivery Tray	1
3	CG26	Screw, 10-32 x .75 Button Hd.	12	18	RBM1438A	Stud Assy.	1
4	CB278	Nut, 10-32 Hex.	10	19	CB734	Lockwasher, $\phi$ .500	1
5	RBM1839A	Delivery Tray Bracket	1	20	RBM1630F	Washer	1
6	CG26N	Screw, 8-32 x .75 Button Hd.	4	21	RBM1842F	Conveyor Wheel Bracket	2
7	RBM1821F	Bearing	2	22	RBM1828F	Nut Bar	2
8	RBM1572F	Idler Shaft	1	23	CGG44C	Thumb Screw Assy.	2
9	RBM1073A	Pulley Assy.	2	24	CB1262	Washer	2
10	CB837B	Retaining Ring, $\phi$ .375	4	25	CB154	Screw, 10-32 x .625 Soc. Hd.	2
11	RBM1827F	Conveyor Drive Shaft	1	26	CB860B	Nut, 10-32 Elastic Stop	2
12	RBM1826A	Index Collar Assy.	1	27	RBM1835A	Conveyor Wheel Assy.	2
13	RBM1312F	Split Collar	7	28	RBM1837F	Conveyor Wheel Shaft	1
14	RBM1072F	Pulley	2	29	RBM1888A	Stop Block Assy.	1
15	D22872F	Screw, 10-31 x .25 Set	2				

# Stitch'n Fold

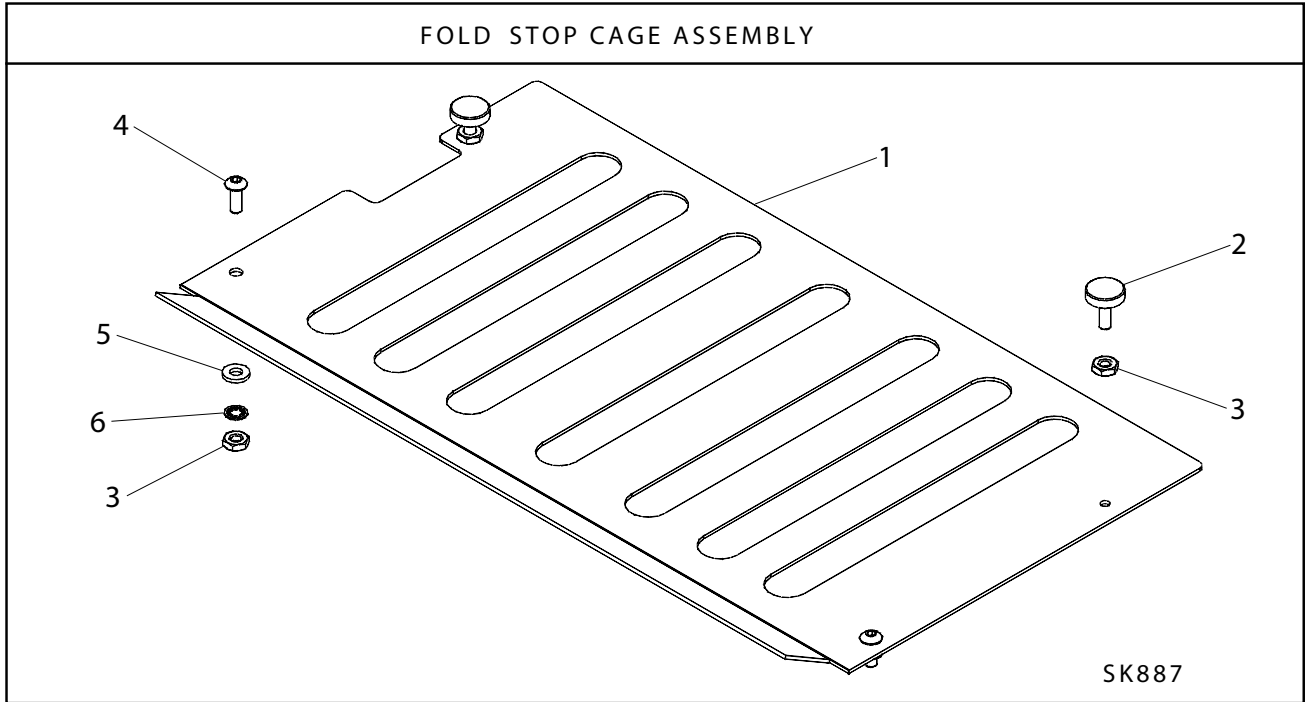

Index Number	Part Number	Part Name	Number Required	Index Number	Part Number	Part Name	Number Required
1	RBM1773F	Fold Stop Cage	1	4	CG26A	Button Hd Scr	2
2	CG44C	Thumb Screw	2	5	CB1262	Washer #10	2
3	CB278	Nut 10-32	4	6	CB988	Lockwasher #10	2

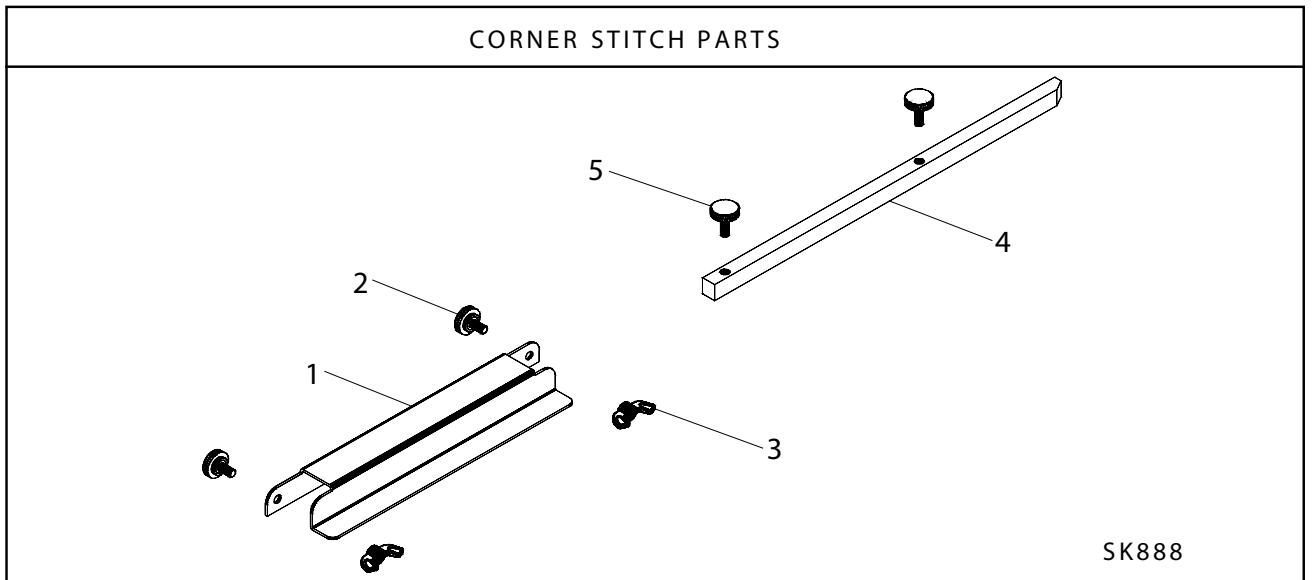

Index Number	Part Number	Part Name	Number Required	Index Number	Part Number	Part Name	Number Required
1	RBM1745F	Corner Stitch Guide	1	4	RBM1322F	Corner Stitch Bar	1
2	CGG44B	Thumb Screw 10-32 x 3/8	2	5	CGG44	Thumb Screw 10-32 x 5/8	2
3	RBM1702F	Wing Nut 10-32	2				

# Stitch'n Fold

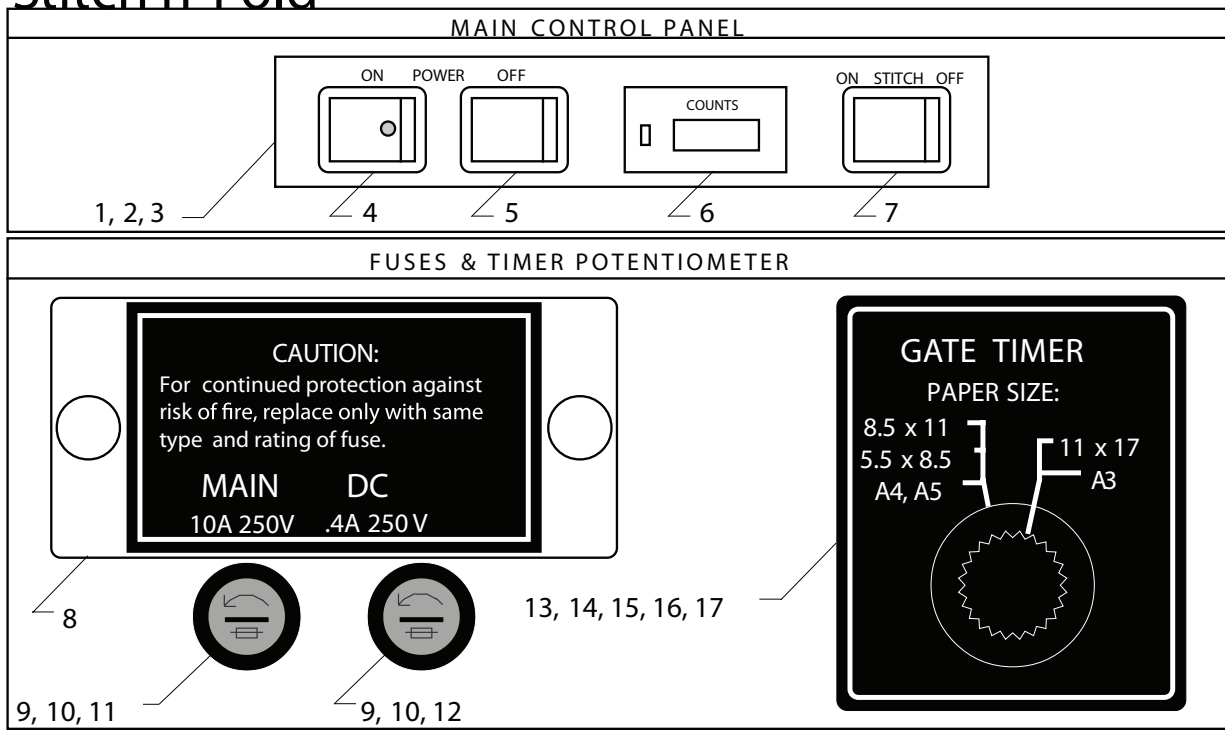

Index Number	Part Number	Part Name	Number Required	Index Number	Part Number	Part Name	Number Required
1	RBM1712F	Main Control Panel Decal	1	35*	RBM1428F	Rubber Grommet	6
2	RBM1713F	Bracket	1	36*	RBM1640F	Relay Bracket	1
3	RBM1324F	Pan Hd Scr 10-32 x 1/2	2	37*	RBM1324F	Pan Hd Scr 10-32 x 1/2	2
4	RBM1714F	Green Illum. Momentary Switch	1	38*	RBM1355F	Power Relay (1CR)	1
5	CG136	Red Rocker Switch (non-CE)	1	39*	CB287E	Rd Hd Scr 6-32 x 1/2	4
	RBM1491F	Emergency Stop (CE only)	1	40*	CB720	Nut 6-32	4
	RBM1492F	Contact Block (CE only)	1	41*	RBM1416F	Timer - Single Shot	1
6	RBM1445F	Counter	1	42*	RBM1817F	Cable Tie	1
7	CG138	Black Selector Switch	1	43*	RBM1417F	Timer Socket	1
8	RBM1726A	Fuse Holder Decal	1	44*	D32127F	Rd Hd Scr 6-32 x 3/4	2
	RBM1324F	Pan Hd Scr 10-32 x 1/2	2	45*	CB720	Nut	2
9	RBM1619F	Fuse Holder Body	2	46*	RBM1501A	Transformer	1
10	RBM1618F	Fuse Holder Carrier	2	47*	RBM1323F	Pan Hd Scr 8-32 x 1/2	2
11	RBM1352F	Main Fuse 10A	1	48*	RBM1298F	Rectifier	1
12	RBM1350F	DC Fuse .4A	1	49*	RBM1324F	Pan Hd Scr 10-32 x 1/2	1
13	RBM1418F	Timer Potentiometer	1	50*	RBM1234F	Stitch Gate Solenoid	1
14	RBM1611F	Potentiometer Bracket	1	51*	RBM1567F	Fold Solenoid	1
15	RBM1324F	Pan Hd Scr 10-32 x 1/2	2	52*	RBM1227F	Clutch (Fold)	1
16	RBM1419F	Potentiometer Knob	1	53*	RBM1443F	Quencharc (QA)	1
17	RBM1695F	Gate Timer Decal	1	54*	CB285R2	Fold On/Off Switch	1
18*	RBM1354F	Power Cord	1	55*	RBM1748F	Clutch (Stitch) (Standard)	1
19*	RBM1668F	Power Cord Bracket	1		RBM1792F	Clutch (Stitch) (Hi-Torque)	1
20*	RBM1323F	Pan Hd Scr 8-32 x 1/2	2	56*	RBM1880A	Wiring Harness	1
21*	RBM1495F	Power Inlet	1	57*	RBM1742F	Cap (corner/side stitch socket)	1
22*	CB808	Flat Hd Scr 5-40 x 3/8	2	58*	RBM1747F	Socket (for RBM1742F)	4
23*	D27398F	Elastic Stop Nut	2	59*	RBM1347F	Motor (230V, 50Hz)	1
24*	RBM1240F	Terminal Block	1		RBM1811F	Motor (230V, 60Hz)	1
25*	D32127F	Rd Hd Scr 6-32 x 3/4	4	60*	CG15B	Microswitch (6LS)	1
26*	CB720	Nut 6-32	4	61*	RBM1371F	Solenoid, Jog & Side Stitch	2
27*	CB1070B	Green Ground Screw	1	62*	RBM1746F	Microswitch (7LS)	1
28*	RBM1711F	Ground Label	1	63*	RBM1875F	Time Delay Module (2TR)	1
29*	RBM1494F	Line Filter (CE only)	1	64*	RBM1496F	Capacitor	1
30*	RBM1225F	Microswitch (3LS)	1	65*	RBM1877F	Resistor	1
31*	RBM1310F	Microswitch (4LS, 5LS)	2	66*	RBM1878F	Rectifier	1
32*	RBM1277F	Interlock Switch (1LS, 2LS)	2	67*	RBM1879F	Terminal Block	1
33*	RBM1328F	Rd Hd Scr 4-40 x 3/4	4	68*	RBM1338F	Cable Tie	1
34*	CG13	Nut 4-40	4	69*	RBM1882F	Cable Tie Holder	1

\* Not shown; see Schematic.

# ELECTRICAL SCHEMATIC

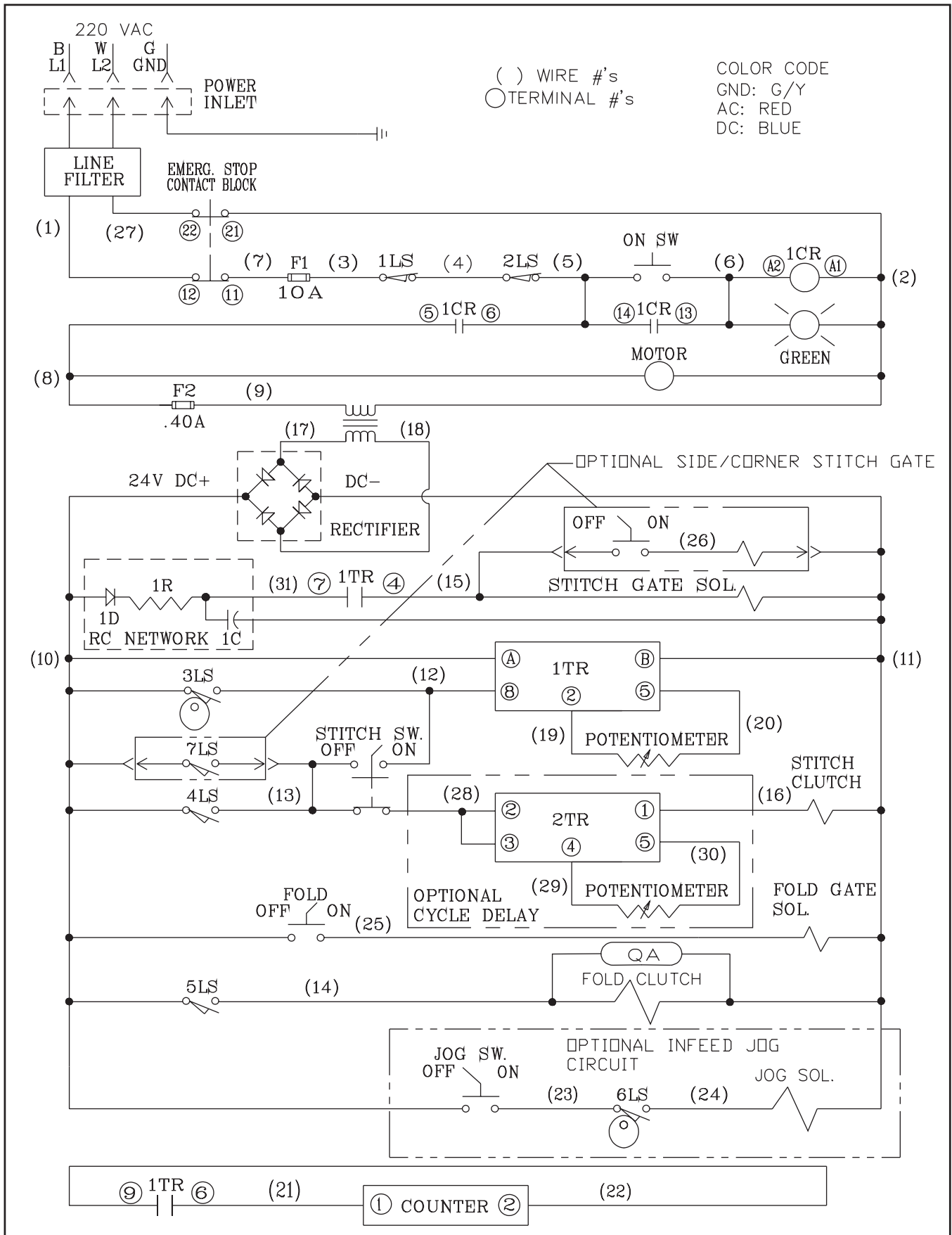

(SK881A)



# Stitch'n Fold

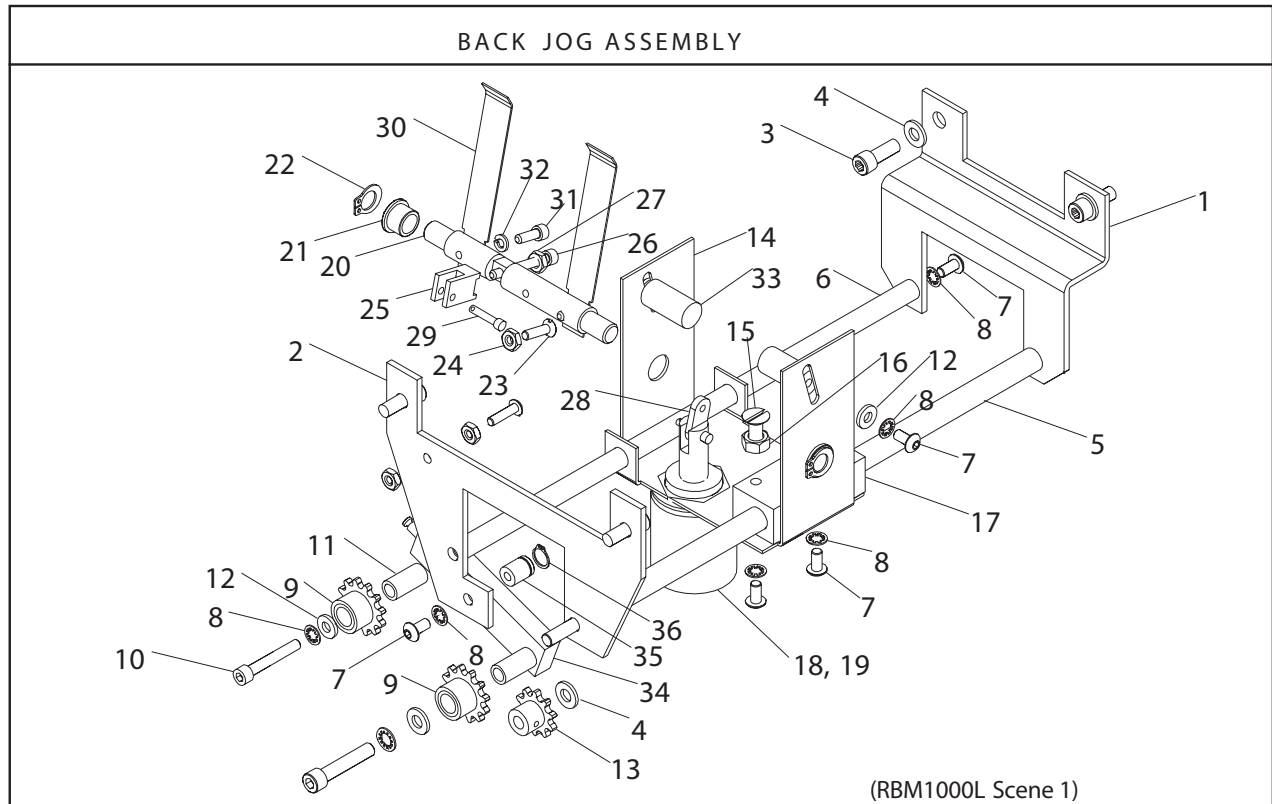

Index Number	Part Number	Part Name	Number Required	Index Number	Part Number	Part Name	Number Required
1	RBM1625	Front Jog Plate	1	28	RBM1374F	Jog Link	1
2	RBM1606F	Rear Jog Plate	1	29	RBM1720F	Clevis Pin	2
3	CB325	Soc Hd Scr 1/4-20 x 1/2	4	*	CB451	Cotter Pin	2
4	CB806	Washer 1/4	5	30	RBM1631F	Jog Finger	2
5	RBM1599F	Threaded Guide Rod	1	31	D30523F	Soc Hd Scr 8-32 x 1/2	2
6	RBM1603F	Guide Rod	1	32	D14267F	Lockwasher, No. 8	2
7	CG26	Button Hd Scr 10-32 x 3/8	6	33	RBM1787F	Finger Stop	2
8	CB988	Lockwasher #10	8	34	RBM1725A	Tensioner Bar Assy	1
9	RBM1218A	12 Tooth Sprocket	2	35	RBM1289F	Idler Stud	1
*	RBM1683F	Back Jog Chain	1	36	CB837B	Retaining Ring	1
10	CB651D	Soc Hd Scr 10-32 x 1 1/4	2	*	RBM1753F	Extension Spring	1
11	RBM1289F	Idler Stud	2	*	CBB283E2	12" Wire (#11 to Jog Solenoid)	1
12	CB1262	Washer #10	4	*	CBB283F2	18" Wire (#10 to Jog On-Off)	1
13	RBM1269C	10 Tooth Sprocket	1	*	CBB283G2	26" Wire (6LS to Jog On-Off)	1
14	RBM1610F	Jog Bracket	1	*	CBB283H2	18" Wire (6LS to Jog Solenoid)	1
15	CB492	Flat Hd Scr 1/4-20 x 1 1/4	1	*	CB285R2	Jog On/Off Switch	1
16	CB493	Nut 1/4-20 Hex	2	*	RBM1440F	Spacer (Switch)	1
17	RBM1632F	Guide Block	1	*	CB651	Soc Hd Scr 10-32 x 1/2	2
18	RBM1371A	Solenoid and Components	1	*	CB278	Nut, 10-32 Hex	2
19	CB2063	Washer 1 ID x 1 1/2 OD	1	*	CG15B	Switch	1
20	RBM1626F	Jog Shaft	1	*	CG14B	Rd Hd Scr 4-40 x 5/8	2
21	RBM1250F	Bushing, .375 Dia	2	*	RBM1638F	Cam	1
22	RBM1586F	Retaining Ring	2				
*	RBM1375F	Extension Spring	1				
23	CB206B	Flat Hd Scr 8-32 x 5/8	1				
24	CB719	Nut, 8-32 Hex	1				
25	RBM1368F	Jog Crank	1				
26	CB56X	Soc Hd Scr 8-32 x 1 3/8	1				
27	CB719	Nut, 8-32 Hex	1				

\* Not shown

SIDE/CORNER STITCH GATE (OPTIONAL)

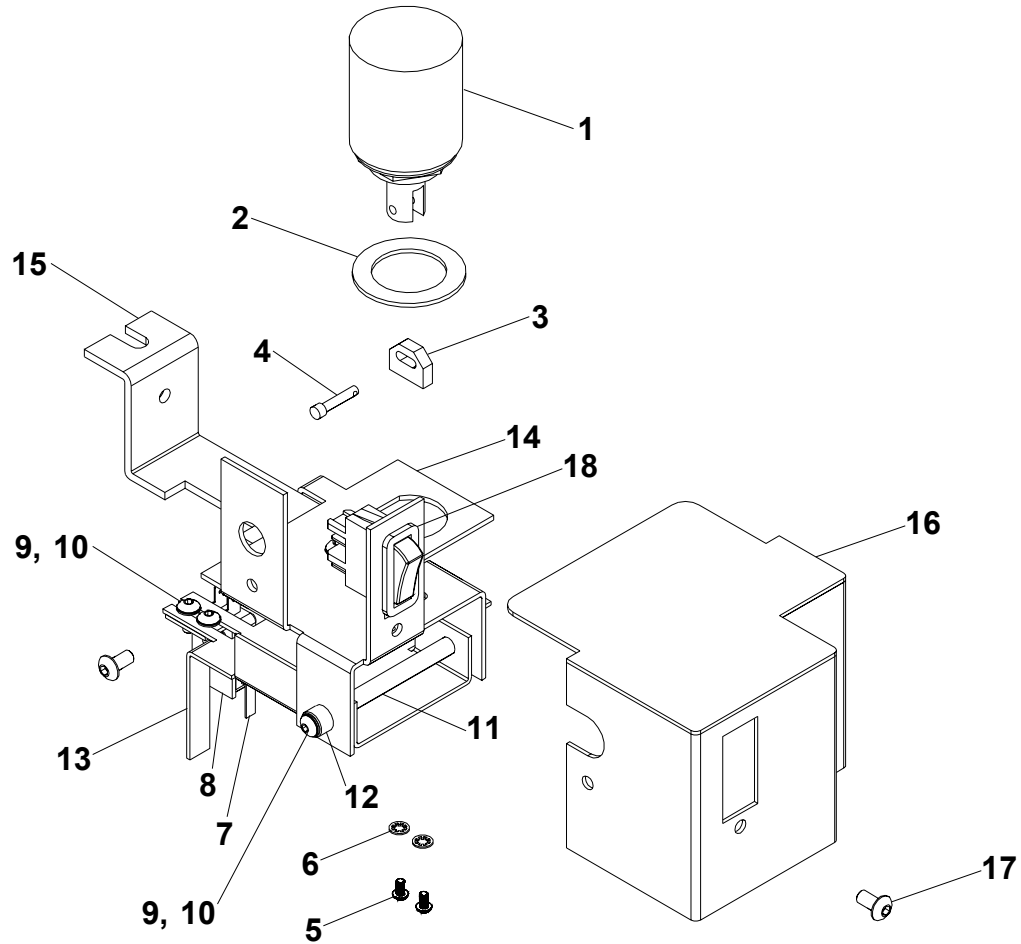

SK889

Index	Part	Part Name	Number	Index	Part	Part Name	Number
1	RBM1371F	Solenoid	1	16	RBM1730F	Cover	1
2	CB2063	Washer 1" x 1 1/2"	1	17	CG26	Button Hd Scr #10-32 x 3/8	2
3	RBM1272F	Solenoid Pivot Bracket	1	18	CB285R2	ON/OFF Switch	1
4	RBM1720F	Clevis Pin	1	*	RBM1733F	Wing Hd Scr 1/4-20 x 1/2	1
*	CB451	Cotter Pin 1/16 x 1/2	1	*	RBM1517F	Strain Relief Bushing	1
5	CB287A	Rd Hd Scr 6-32 x 1/4	2	*	RBM1477F	Pan Hd Scr #6 x 7/16	2
6	CK50	Lockwasher #6	2	*	RBM1743F	Plug	1
7	RBM1746F	Microswitch	1	*	CK108	Contact Pin	4
*	RBM1327F	Rd Hd Scr 4-40 x 1/2	2	*	RBM1744F	Strain Relief	2
8	RBM1506F	Switch Bracket	1	*	RBM1724F	Cable	1
9	CG26N	Button Hd Scr 8-32 x 3/8	4	*	RBM1342F	Paper Ski	1
10	CB988A	Lockwasher #8	4	*	CG26A	Button Hd Scr #10-32 x 1/2	1
11	RBM1731F	Gate Shaft	1	*	RBM1702F	Wing Nut 10-32	1
*	RBM1666F	Torsion Spring	1				
12	RBM1249F	Plastic Bearing	2				
13	RBM1727F	Stop Platform	1				
14	RBM1728F	Solenoid Bracket	1				
15	RBM1729F	Mtg. Bracket	1				
*	CG26A	Button Hd Scr #10-32 x 1/2	2				
*	CB988	Lock Washer #10	2				

\* Not shown

# Stitch'n Fold

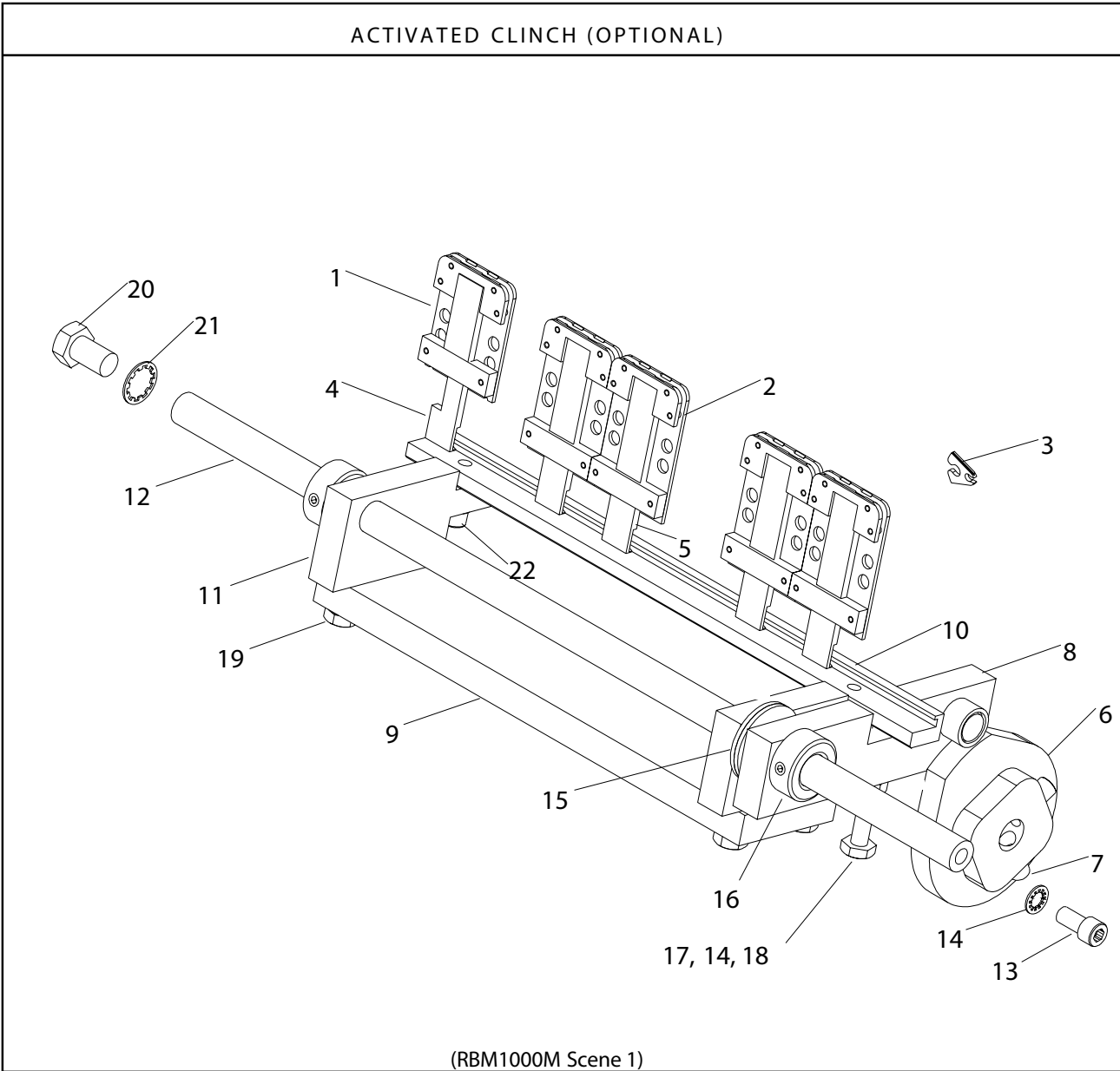

Index Number	Part Number	Part Name	Number Required	Index Number	Part Number	Part Name	Number Required
1	RBM1453F	Short Clincher Assy	1	12	RBM1639F	Shaft	1
2	RBM1457F	Clincher Assy	4	13	CB325	Soc Hd Scr 1/4-20 x .500	1
3	CA9083A	Clincher Point (inside Assy's)	10	14	RBM1519F	Lockwasher 1/4	2
4	RBM1460F	Short Clincher Slide	1	15	CB198	Washer 1/2 x 1 1/4	2
5	RBM1461F	Clincher Slide	4	16	RBM1657F	Split Collar	2
6	RBM1521F	C lincher Cam	1	17	RBM1795F	Hex Hd Scr 1/4-20 x 2	1
7	CB155	Set Scr 5/16-18 x .500	2	18	CB493	Nut 1/4-20	1
8	RBM1703A	Cam Arm Assy	1	19	CB487	Hex Hd Scr 1/4-20 x 3/4	4
9	RBM1756F	Cross Bar	1	20	CB328	Hex Hd Scr 3/8-16 x 5/8	1
10	RBM1458F	Slider Base	1	21	RBM1520F	Lockwasher 3/8	1
11	RBM1463F	Clincher Arm	2	22	CB77A	Soc Hd Scr 1/4-20 x .625	2



# REGISTRATION

To better service your wire stitching needs, please take a moment to fill out and return this registration card.

Name: \_\_\_\_\_  
( First ) ( Middle Initial ) ( Last )

Company: \_\_\_\_\_

Street Address: \_\_\_\_\_

City: \_\_\_\_\_ State/Province: \_\_\_\_\_ Zip: \_\_\_\_\_

Country: \_\_\_\_\_

Phone: \_\_\_\_\_ Fax: \_\_\_\_\_ E-mail: \_\_\_\_\_

CUSTOMER

Machine(s) Purchased: \_\_\_\_\_

Serial Number(s): \_\_\_\_\_

With Head(s): \_\_\_\_\_  
( Type/Quantity Purchased )

Serial Number(s): \_\_\_\_\_

Head(s) Purchased: \_\_\_\_\_

Serial Number(s): \_\_\_\_\_

PRODUCT

Date Received: \_\_\_\_\_

Dealer Name: \_\_\_\_\_

Dealer Street Address: \_\_\_\_\_

City: \_\_\_\_\_ State/Province: \_\_\_\_\_ Zip: \_\_\_\_\_

Country: \_\_\_\_\_

Dealer Phone: \_\_\_\_\_

DEALER

Other Bindery Products Used: \_\_\_\_\_

Please take a moment to fill out the attached card and mail it to DeLuxe Stitcher Company, Inc. In addition, duplicate the information for your records to assist when making further inquiries.

## PRODUCT

Machine(s) Purchased: \_\_\_\_\_

Serial Number(s): \_\_\_\_\_

With Head(s): \_\_\_\_\_  
( Type/Quantity Purchased )

Serial Number(s): \_\_\_\_\_

Head(s) Purchased: \_\_\_\_\_

Serial Number(s): \_\_\_\_\_

## DELUXE STITCHER GRAPHIC ARTS REPRESENTATIVE

Date Received: \_\_\_\_\_

Dealer Name: \_\_\_\_\_

Dealer Street Address: \_\_\_\_\_

City: \_\_\_\_\_ State/Province: \_\_\_\_\_ Zip: \_\_\_\_\_

Country: \_\_\_\_\_

Dealer Phone: \_\_\_\_\_

Would you like information sent to you about new products that would benefit your company?  Yes  No

PLACE  
STAMP  
HERE

\_\_\_\_\_  
\_\_\_\_\_  
\_\_\_\_\_

**DeLuxe Stitcher**  
Company Inc.

3747 N. Acorn Lane  
Franklin Park, IL 60131 U.S.A.  
Attn: Customer Service



WHEN ORDERING PARTS, PLEASE STATE: QUANTITY REQUIRED, PART NUMBER, PART NAME, WIRE SIZE AND CROWN WIDTH OF YOUR STITCHER.



3747 N. Acorn Lane, Franklin Park, IL 60131

Phone: 847-455-4400 800-634-0810

Fax: 847-455-4900 800-417-9251

<https://www.deluxestitcher.com>