

DELUXE STITCHER

C O M P A N Y I N C .

Machine Model : _____ Serial Number : _____

Head Serial Number : _____

Date Purchased/Installed : _____

MiniStitcher

OPERATION AND MAINTENANCE MANUAL

IMS-A25.....MiniStitcher....115 V...25 Wire
IMS-CE25..MiniStitcher...230 V...25 Wire
IMS-A2125.....MiniStitcher....115 V...21x25 Wire
IMS-CE2125....MiniStitcher...230 V...21x25 Wire

Before using this Stitcher, all operators must study this manual and follow the safety warnings and instructions. Keep these instructions with the Stitcher for future reference. If you have any questions, contact your local DeLuxe Stitcher Representative or Distributor.

WARNING!

MiniStitcher

Machine operators and others in the work area should always wear safety glasses to prevent serious eye injury from fasteners and flying debris when loading, operating, or unloading this machine.

Do not operate this stitcher without all guards in place. The stitcher will not operate without the front guard closed properly. Do not modify the guards in any way. Always disconnect the power supply before removing any guards for servicing.

Never operate the machine with wire feeding through the head unless there is stock above the clinchers, otherwise serious damage may result.

Always turn power off when making adjustments. Always disconnect the power cord before any disassembly work.

Table of Contents

Introduction	3
Specifications	4
Installation	5
Pre-Inspection	5
Inspection	5
Set-Up	5
Assembly	6
Operation	7
Wire Threading	7
Wire Straightening	8
Adjustments and Settings	9
Stitching Process	11
Solid vs. Moveable Clinching.....	11
Trip and Stitch Modes.....	12
Troubleshooting	13
Maintenance.....	15
Lubrication	15
Cleaning	16
How to Order Spare Parts.....	16
Replacing Spare Parts.....	17
Modifications	21
Timing	21
Appendices	22
Exploded Drawings	22
Wiring Schematic.....	40
Part Number/Description Cross Reference.....	41
Optional Equipment.....	44
Registration Card	48
Recommended Spare Parts	49
Warranty	50
Declaration of Conformity.....	51

Introduction

The DeLuxe Stitcher MiniStitcher is a table-top version of the StitchMaster. A completely portable stitcher, the MiniStitcher is ideal for closing padded envelopes, carding and blister packs.

There are two StitchMaster models: the IMS-A which operates on 115VAC and the IMS-CE which operates on 230VAC and conforms to all pertinent CE standards. All other performance characteristics of both models are the same.

The MiniStitcher comes standard with parts for 25 gauge or smaller round wire. However, any MiniStitcher can be modified to accommodate any of the following wire sizes: 23 or 24 gauge round or 21 x 25 flat. In addition, the MiniStitcher can be ordered with these alternative wire size parts directly from your DeLuxe Stitcher Graphic Arts Representative.

The MiniStitcher has a capacity up to 1/4" (6.4mm) or sixty sheets of 20 pound bond paper with 25 gauge round wire and up to 1/8" (3.2mm) or thirty sheets of 20 pound bond paper with 21x25 flat wire. It accommodates flat stitching only with a solid Clincher but easily adjusts to control both work thickness and centering the stitch.

The MiniStitcher's foot switch provides for easy operation in either single or continuous stitch modes at the touch of a button. It can be placed on any sturdy work surface and plugs into any standard wall outlet.

The MiniStitcher has a 9" (22.9 cm) throat depth for flat stitching. The overall height of the stitcher is 24" (61.0 cm) and the depth is 13" (33 cm). The width is 9" (22.9 cm) including the base.

Both the IMS-A and the IMS-CE weigh 36 lbs. (16.2 kgs.). The shipping weight including the stitcher, the wire spool and the foot switch is approximately 50 lbs. (22.7 kgs.).

Specifications

Weight

Shipping Weight	50 lbs (22.7 kg)
MiniStitcher Machine Unit	
IMS-A	36 lbs. (16.2 kgs)
IMS-CE	36 lbs. (16.2 kgs)
Wire Spool	5 lbs. (2.3 kgs)
Foot Switch	4.5 lbs. (2.0 kgs)

Physical Dimensions

Height	24" (61.0 cm)
Width	9" (22.9 cm)
Depth	13" (33.0 cm)

Stitching Capacity	Two Sheets to 1/4" (6.4 mm) with 25 gauge round wire
	Two Sheets to 1/8" (3.2 mm) with 21 x 25 flat wire

Wire Sizes	25 through 28 round or 21 x 25 flat (25 gauge round standard)
------------	--------------------------------------------------------------------

Throat Depth

Flat (Horizontal)	9" (22.9 cm)
-------------------	--------------

Power Requirements

IMS-A	115VAC 50/60 Hz
IMS-CE	230VAC 50/60 Hz

Minimum Recommended Circuit Capacity

IMS-A	1.0 A
IMS-CE	0.7 A

Installation

Pre-Inspection

Carefully inspect the condition of the shipping container before unpacking your MiniStitcher. If the container is broken or damaged and there is evidence that the machine may be damaged, immediately notify the carrier who delivered the stitcher and the DeLuxe Stitcher Graphic Arts Representative from whom the machine was purchased.

Inspection

As you carefully unpack the machine, check to make sure all components were delivered and are in good working order. Use **Figure 2** in this manual for reference to the following pieces:

- MiniStitcher
- Foot Switch with a Guard and Cord (PG10230)
- Wire Spool (25G5 or 2125G5 - optional) on a Spool Shaft (MG10110)
- Spool Cradle (MG10113)
- Wire Guide Spring (MG10009A)
- Table Base (MG10180)
- Driver Release Pin (5160)
- 1/8" Hex Key Wrench (PG10293)
- Stitch samples

Note: Check the nameplate on the back of the stitcher to verify the operating voltage meets your requirements.

Set Up (Figure 1)

Place the MiniStitcher in a location where the operator will have sufficient light and working space. Ensure the machine is set up on a sturdy table, heavy enough to support its weight. For added stability, remove the Table Base (MG10180) and screw the MiniStitcher to a stable worktable or to a MiniStitcher Floor Stand (an optional purchase). Unsuitable Stands will have a tendency to tip onto the operator.

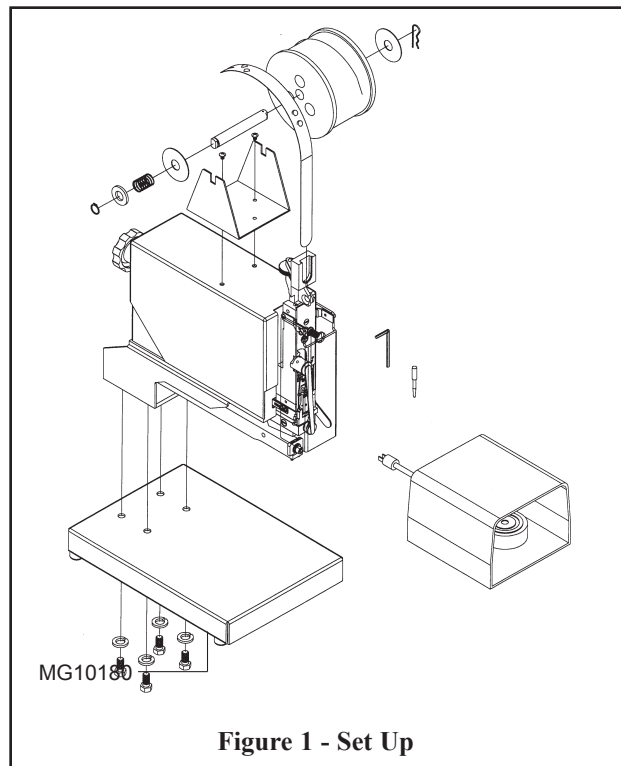

Assembly (Figure 2)

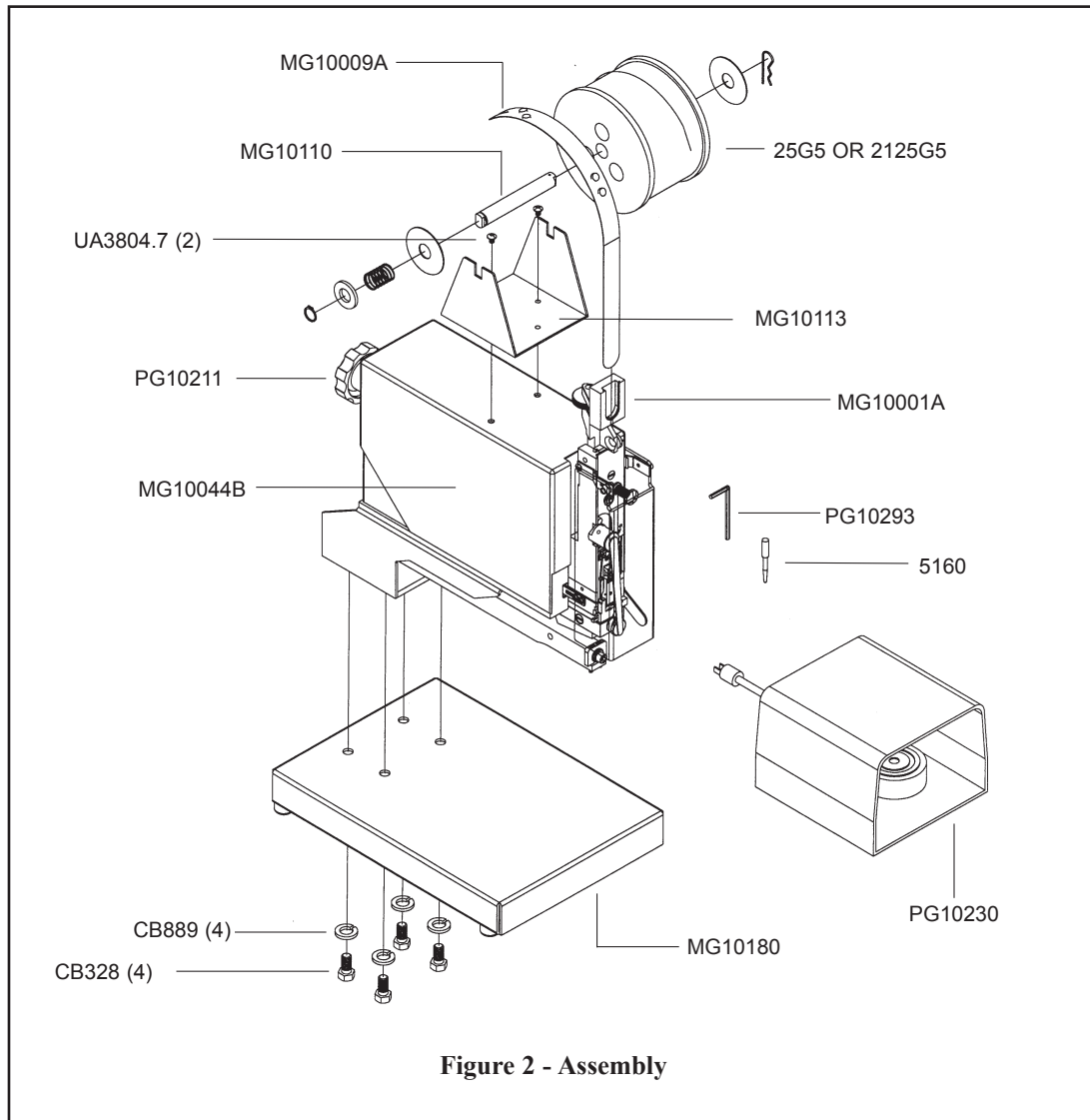

Figure 2 - Assembly

Always disconnect the power cord before assembling the MiniStitcher or making any adjustments.

CAUTION

Assemble the components of the MiniStitcher. Use **Figure 2** for part number reference.

The MiniStitcher mounts on the Table Base (MG10180) and is secured with four (4) Screws (CB328) through four (4) Lock Washers (LW12.2). The Wire Spool Cradle (MG10113) mounts with two (2) screws (UA3804.7) on the top of the cover (MG10044B). Use the supplied 1/8" Hex Key Wrench (PG10293) to remove the screws and then secure the Cradle to the Cover. The Wire Spool (25G5 or 2125G5) comes assembled on the Spool Shaft (MG10110) which slips into the slots in the

cradle. Make sure that the wire payoff is from the top of the spool, as shown in **Figure 2**. The Wire Guide Spring (MG10009A) slides into the slot in the Wire Guide Spring Bracket (MG10001A) on the top of the Head located at the front of the machine.

Once the assembly is complete, turn the machine over by hand a few times using the Shaft Extension Handle (PG10211) located at the rear of the unit. All parts must operate freely before turning on the power. Push and turn the handle counter-clockwise (looking from the rear of the machine) to manually rotate the machine. You are ready to plug in your MiniStitcher, but do not turn on the main power yet.

Operation

Wire Threading (Figure 3)

Before the machine is turned on, raise the Head Guard (PG10003), disengage the Swivel Operating Spring (9046A) and remove the Swivel Assembly (9038M or 9038A). Thread the wire from the Spool (refer to **Figure 2** for the correct wire payoff) through the Wire Guide Spring (MG10009A), between the flanges of the Wire Straightener Rollers (9103) on the Wire Guide Spring Bracket (MG10001A) as well as between the Wire Straightener Bushing (9068) and the Wire Straightener Rollers (9103) on the Face Plate (2132BA). Continue to pull the wire through the Tension Pawl (9098), through the hole in the Face Plate in the top of the Wire Cutter (9048) Holder and through the Swivel Holder (9043B). At this point, do not worry if the wire is not fed between the Grip (9015) and the Grip Holder area.

Note: The Tension Pawl will hold the wire in the groove in the Wire Straightener Roller (9103). This will allow the wire to feed through the Head but not allow it to “back-up.”

Pull enough wire through the bottom of the Head to clear away what was bent in the

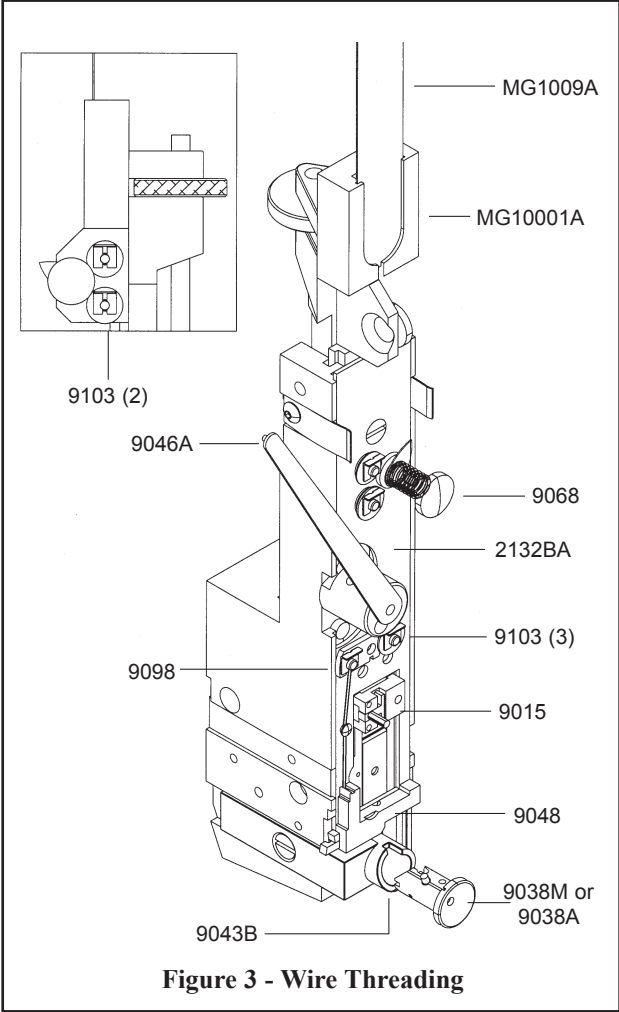

Figure 3 - Wire Threading

threading process. With the Swivel still removed, power the MiniStitcher on and switch the Trip Mode Switch (PG10232), found on the back of the Machine, to single mode stitching. Replace the Head Guard and trip the Foot switch to allow the wire to automatically thread between the Grip and the Grip Holder. This will also cut off any excess wire below the Cutters.

Wire Straightening (Figure 4)

Wire straightness is important so that the stitches are loaded, driven and closed properly. Although straightness is set at the factory, every roll of wire has varying degrees of twist which makes it necessary for the user to properly straighten the wire prior to production. Easy steps for straightening the wire are listed below.

Make sure the Swivel has been removed before tripping the MiniStitcher to avoid jams and the chipping of parts.

WARNING

Remove the Swivel Assembly (9038M or 9038A), the Swivel Operating Spring (9046A) and the Swivel Operating Hub (9163). The Swivel Operating Spring is easily removed after rotating it to a position comparable to 10:00 on the face of a clock and pulling. Switch the Trip Mode Switch (PG10232), found on the back of the Machine, to continuous stitching and activate the Foot Switch (PG10230). Watch the feeding of the Wire through the Swivel Holder (9043B). Notice the direction the Wire is moving as it feeds out of the bottom of the head. To compensate for some of the Wire Spool's (25G5 or 21256G5) natural curve, the wire optimally should be feeding slightly to the right. Use the Wire Straightener Eccentric Nut (9067) on the Face Plate (2132BA) to adjust the wire.

Right-to-Left Adjustment

Look through the Swivel Holder (9043B) at the Wire being fed through the Head. If the Wire is feeding to the left or perfectly

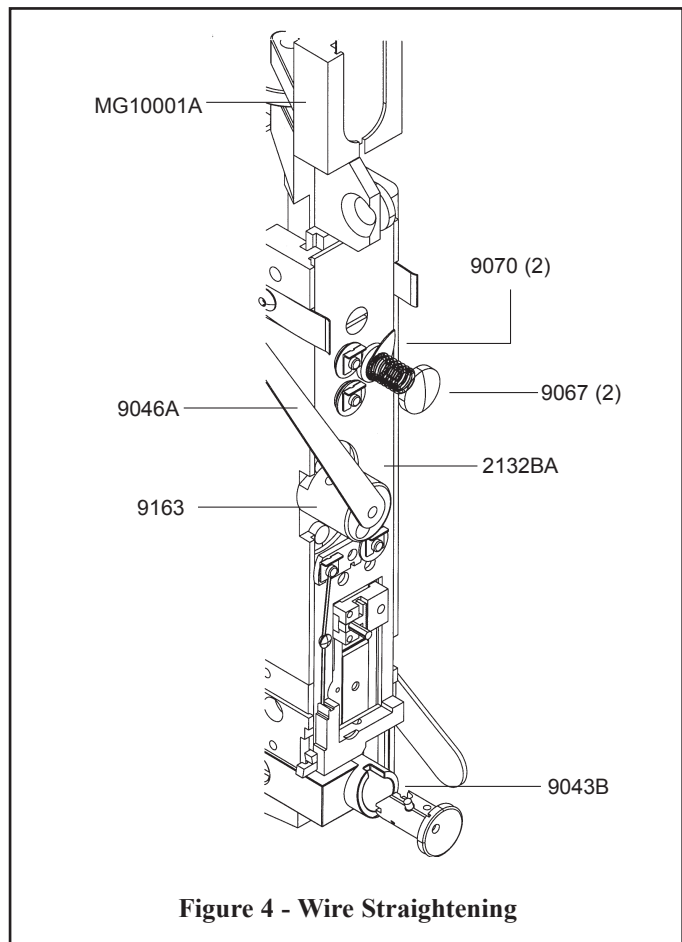

Figure 4 - Wire Straightening

straight up and down, adjust the Wire Straightener Nut (9067) so that the Wire Straightener Pointer (9070) turns counter-clockwise. Remember, the MiniStitcher works optimally if the Wire curves slightly to the right. Allow enough Wire to be fed through the Head so that an accurate assessment can be made. After an adjustment is made it takes approximately four to six stitches to take effect. If the Wire is feeding too far to the right, adjust the Wire Straightener Nut so that the Wire Straightener Pointer turns clockwise.

Front-to-Back Adjustment

Look at the Wire feeding through the Head from the side and make sure that it is straight front-to-back. The Wire Straightener Eccentric (9067) on the Wire Guide Spring Bracket (MG10001A) adjusts the curve if it is not straight. Setting the Wire Straightener Pointer (9070) at a position comparable to 7:00 on the face of a clock is a good place to start. If the Wire is feeding too far to the front, adjust the Wire Straightener Eccentric so that the Wire Straightener Pointer turns clockwise. Allow enough wire to be fed through the Head, about four to six stitches, to make an accurate assessment. If the wire is feeding too far to the back, adjust the Wire Straightener Eccentric so that the Wire Straightener Pointer turns counter-clockwise.

Adjusting the Wire Draw (Figure 5)

Once the MiniStitcher has been threaded and the wire straightness has been obtained, it is time to begin stitching. Replace the Swivel Assembly (9038M or 9038A), the Swivel Operating Hub (9163) and the Swivel Operating Spring (9046A). Set the Trip Mode Switch (PG10232), found on the back of the Machine, to single stitching.

NOTE: The continuous Trip Mode is used primarily for oiling and wire straightness adjustment.

Activate the Foot Switch (PG10230) once to load a piece of wire into the Swivel. Even though the MiniStitcher has been tested at the factory, the wire draw adjusted and the legs equalized, the following are directions to make these adjustments if necessary. One control, the Face Plate Adjustment Knob (MG10013), controls both the length of the left leg and wire draw.

The overall length of the stitch is controlled by the amount of wire that is drawn from the spool after each stroke of the MiniStitcher. To change the overall length of the stitch, loosen the Face Plate Adjusting Lock Screw (9799) on the front of the Head.

Always disconnect the power cord before making any adjustments or servicing the MiniStitcher

 **WARNING**

Adjusting the Length of the Left Leg (Figure 5)

Do not operate the MiniStitcher Stitcher until all guards are in place

CAUTION

Turn the Face Plate Adjustment Knob clockwise to raise the Face Plate which draws more wire - making the overall length of the stitch longer. If the overall length is too long, turn the Face Plate Adjustment Knob counter-clockwise to lower the Face Plate and decrease the draw of wire pulled from the Wire Spool. Once the correct length of wire has been achieved, tighten the Face Plate Adjusting Lock Screw. As a rough gauge, the distance the Face Plate is above the Bonnet (2601R) should be equal to the work thickness.

NOTE: If the Face Plate is adjusted too high (turning the Face Plate Adjustment Knob too far clockwise) the Grip (9015) will lock in an open position and draw no more wire. The MiniStitcher has a capacity of 1/4" and will allow no more than that amount of wire to be drawn from the spool.

Adjusting the Stitch's Left Leg

If after a few stitches, the length of the stitch's left leg is too short compared to that of the right, you will need to adjust the Wire Guide Spring Bracket (MG10001A). Loosen the Wire Guide Spring Bracket Screw (9075) found on the side of the Head. Turn the Face Plate Adjustment Knob clockwise and tighten the screw. If the length of the left leg is too long, loosen the Wire Guide Spring Bracket Screw and turn the Face Plate Adjustment Knob counter-clockwise. After the length of the stitch's left leg is satisfactory, make sure to tighten the screw again.

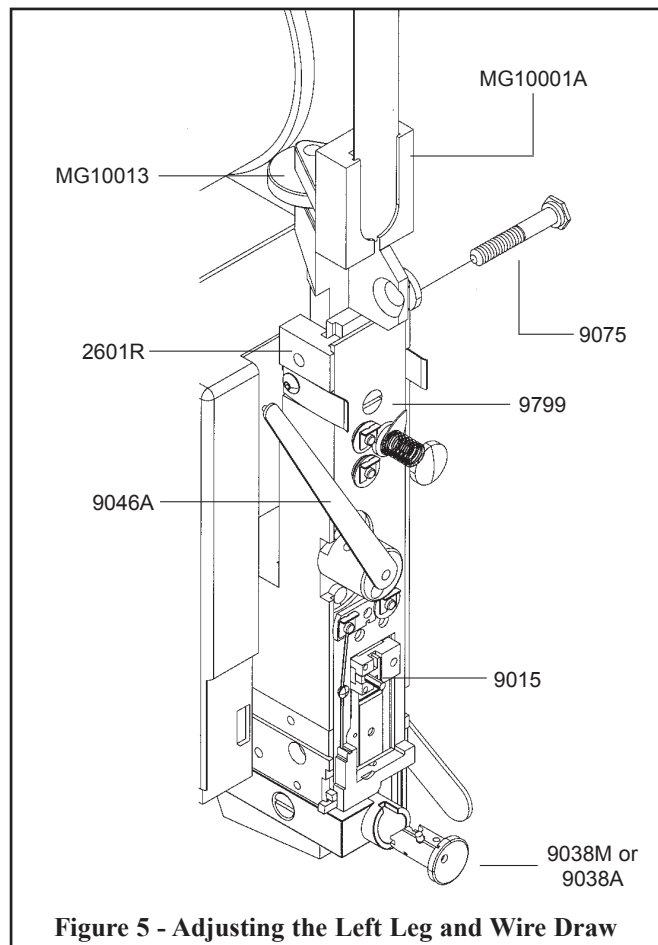

Figure 5 - Adjusting the Left Leg and Wire Draw

Stitching Process

The MiniStitcher has been specifically designed to use a solid Clincher Plate. For this reason, adjustable work tables and table trips have not been installed on the MiniStitcher. Following is a brief explanation of options available for the machine.

Solid Clinching (Figure 6)

The Solid Clincher (MG10178) is attached to the Platform Weldment (MG10170A) on every MiniStitcher. Because the Clincher is mounted to a stationary Clincher Arm, the legs of each stitch are bent when the wire is pushed through the stock and hits the Clincher as opposed to the Clincher Points on moveable Clincher Plates coming up to meet the wire. Having fewer moving parts supporting this process results in a more solid brace for the stitches as they are driven into the stock, a more sustained capacity and fewer wear parts to replace.

Minor adjustments can be made to the Solid Clincher if necessary. Loosen the Screw (UA4808.3) retaining the Solid Clincher on the Clincher Arm to adjust the Clincher side to side.

The Back Stop (MG10076) attaches to the Clincher Arm with a Thumb Screw (P2731) and is used to consistently locate the depth of the stitch.

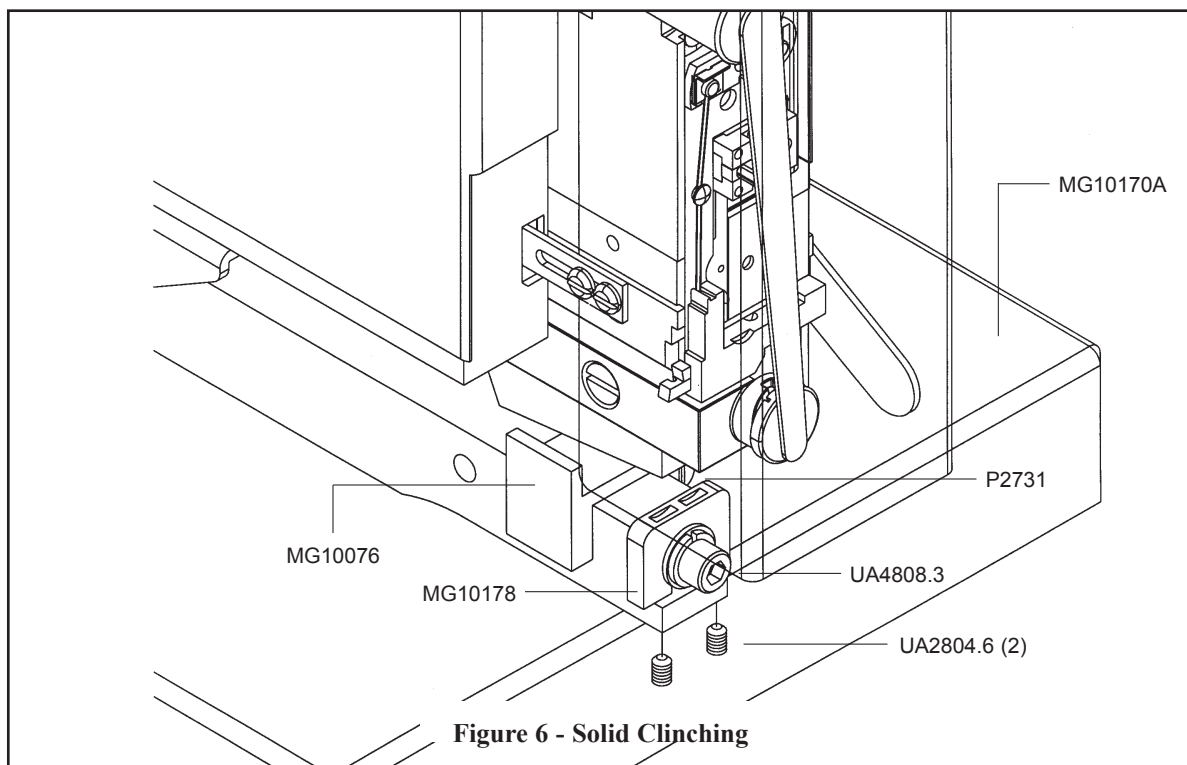

Stitch Mode

The Stitch Mode Switch (PG10232) is found on the back of the MiniStitcher. (The switch on the left, looking from the rear of the machine.) There are two stitching modes: single or continuous. Single stitching is used for production. In the single trip mode only one stitch will be released at a time, no matter how long the trip switch is activated. With the continuous stitch mode, the machine will continue to deliver stitches as long as the Foot Switch is activated. The continuous stitch mode is used only for lubricating, testing and trouble-shooting.

Trip Mode

The Trip Mode Switch (PG10232) is also found on the back of the MiniStitcher. (The switch on the right, looking from the rear of the machine.) Either the foot trip or the table trip mode can be selected even though the standard MiniStitcher comes complete with only a Foot Switch (PG10230). The Contact Trip (MG10164) can be purchased separately in the IMSK2 Kit and uses the Trip Mode Switch toggled in the table trip mode.

Be sure that the Foot Switch (PG10230) is plugged into the rear of the MiniStitcher and the Trip Mode Switch is toggled for this mode before work is begun. The Foot Switch will not activate the MiniStitcher if the Trip Mode Switch is toggled in the table trip mode.

Trouble Shooting (Figure 7)

Following is a brief list of problems and solutions which covers the most common situations encountered when stitching with the MiniStitcher. Most problems with stitches are due to incorrect adjustments on the machine or to the normal wear of parts.

PROBLEM: The machine does not cycle but the Main Power Switch (PG1022B) is on.

SOLUTION: Make sure the Power Cord (P2581 or PG10410) is properly plugged into a live receptacle. Check to see if the Circuit Breaker (PG10234 or PG10406) has been tripped. If so, push it to reset. If it still does not cycle, make sure the Foot Switch (PG10230) is plugged in and the correct Trip Switch position is selected. The Head Guard (PG10003) must be in place to fully depress the safety interlock, otherwise the MiniStitcher will not function.

NOTE: If the Head Guard moves enough to lose contact with the Safety Switch (PG10229) the Head Guard must be rotated upward to clear the Safety Switch and re-closed.

PROBLEM: The wire is being cut but dropped before it can be formed.

SOLUTION: Make sure that the wire is feeding straight, or slightly to the right, from the Wire Spool through the Wire Straightener Eccentric (9067) and the Wire Straightener Nut (9067). Allow enough wire to feed through the head and trip the MiniStitcher. If the problem continues, check to see if there is enough tension in the Swivel Operating Spring (9046A). The Swivel has to get close enough to the wire in the Bender Bar (9013BA-25 or 9013BA-21x25) to engage it. Check the Latch (9014) and the Driver (9009-25 or 9009-21x25) for wear.

PROBLEM: There is inconsistent wire draw (indicated by varying lengths in the staple legs).

SOLUTION: Check to see if the Grip (9015) is worn and needs to be reversed or replaced, or if the Grip Spring (9019) is stretched out. If an inconsistent amount of wire is being drawn from the Spool, the legs of the staples will vary. Wire draw could also be restricted by the Tension Pawl (9098) or the Tension Pawl Spring (9134) being too tight or too loose causing the wire to back up into the head. If wire is not being easily fed between the Tension Pawl and the Wire Straightener Roll (9103) on the Face Plate, consistent wire draw is adversely affected.

PROBLEM: More than one piece of wire is loading into the Swivel (9083M or 9083A).

SOLUTION: The Bender Bar Friction Plug (9112B) may be worn as well as the Bender Bar Friction Spring (9113B). If the Bender Bar (9013BA-25 or 9013BA-21x25) does not retract enough to allow the Swivel Assembly (9038M or 9038A) to return to its normal position, the head will not drive the wire into the stock and it will remain in the Swivel.

PROBLEM: The wire is being bent, not cut or is jamming along the Face Plate (2132BA).

SOLUTION: First check to see that the Cutters (9048) do not have to be reversed or replaced. If their surfaces are not dull check to see if the Wire Cutter Operating Slide (9049) is worn or if the Cutter Holder in the Face Plate is worn.

Do not operate the MiniStitcher Stitcher until all guards are in place

 **CAUTION**

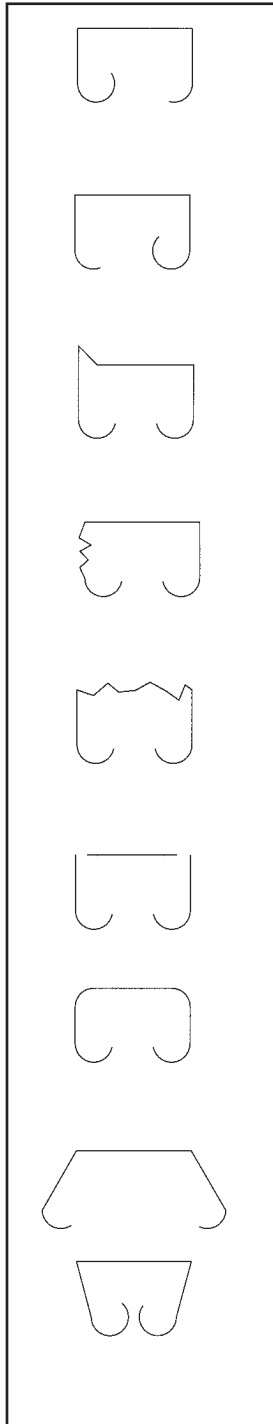

PROBLEM: Right Leg Short

SOLUTION: Shorten the left leg and then lengthen both of the stitch's legs. (See pages 10 - 11)

PROBLEM: Left Leg Short

SOLUTION: Lengthen the left leg. Check the Grip for wear and rotate or replace it if needed. (See page 11)

PROBLEM: Corner Buckled

SOLUTION: Check the Driver for a chipped corner and rotate or replace it if needed. (See page 21)

PROBLEM: Leg(s) Buckled

SOLUTION: Check the Wire Cutters for wear and rotate or replace if needed. (See page 19)

PROBLEM: Crown Buckled

SOLUTION: Check Supporter Spring (9032) tension. If it is too loose adjust it.

PROBLEM: Stitch in Pieces

SOLUTION: Clean and lubricate the Swivel. (See page 17)

PROBLEM: Corners of the Crown are Rounded

SOLUTION: Replace the worn Swivel.

PROBLEM: Legs are Spread or Contracted

SOLUTION: Readjust the Wire Straightener Eccentrics. (See pages 9 and 10) Check the Wire Cutters for wear and rotate or replace if needed. (See page 19) Check the Bender Bar for wear in the grooves and replace if needed.

Figure 7 - Troubleshooting

Maintenance

Lubrication (Figure 8)

Your MiniStitcher has been fully lubricated at the factory, but regular preventative maintenance will result in superior performance and longer life of the machine. A good rule of thumb is to oil the MiniStitcher's critical points every five pound wire spool change or every month, whichever comes first. Use one drop of any standard S.A.E #10 oil in the following lubrication points:

- at the top of the Bonnet (2601R) on either side of the Wire Guide Spring Bracket (MG10001A)
- the oil hole in the Swivel Operating Lever (9163) in the Hub
- the oil holes in the Face Plate (2132BA)
- on the Bender Bar Latch (9014) and on the Grip (9015)
- the oil hole in the Driving Shaft Connection Link (2215)
- the opening in the Swivel Holder (9043B)
- the Wire Cutter Operating Slide slot (9049)
- on the Wire Straightener Rolls (9065) and Tension Pawl (9098)

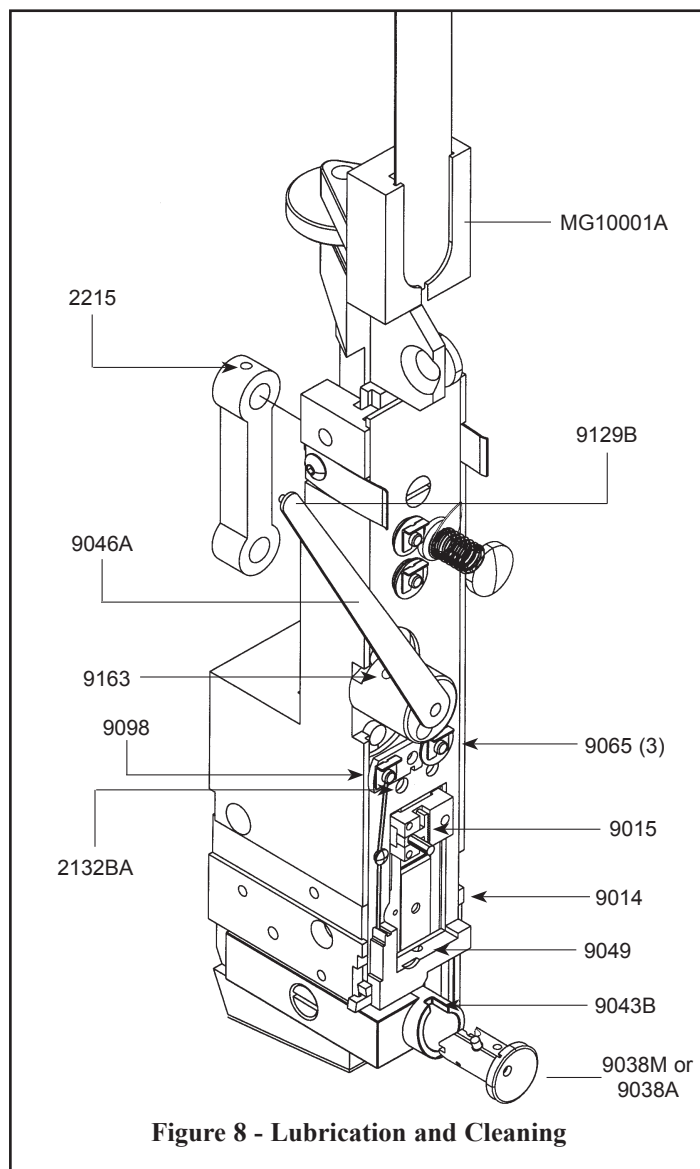

Figure 8 - Lubrication and Cleaning

Always disconnect the power cord
before any maintenance or adjustments are
made to the MiniStitcher

 **CAUTION**

Cleaning (Figure 8)

In addition to proper lubrication, routine cleaning is important for the maintenance of your MiniStitcher. The following areas should be cleaned every three months:

- **Swivel Assembly (9038M or 9038A):** remove and wash in an oil-dissolving solvent, dry and relubricate.
- **Swivel Holder (9043B):** clean inside the Swivel hole with an oil-dissolving solvent.
- **Swivel Operation Lever and Stud:** remove the Swivel Operating Spring (9046A) and Hub (9163). Clean the Swivel Operating Spring Stud (9129B) and the holes of the Hub, relubricate and replace.

Note: Use care when replacing the Swivel Operating Hub (9163) as direction is critical and the Swivel Operating Lever to avoid seriously damaging the head.

- **Anywhere that dust, oil or pieces of wire and paper have built up** - for example: the Grip, Clincher Points and around the Wire Straightener Rollers.

Ordering Spare Parts

In time, you will need to replace some parts in your MiniStitcher. When this happens, first locate the needed part in one of the following diagrams. Then locate the DeLuxe Stitcher part number and contact your Graphic Arts Representative to order the part by the part number, description and quantity. Also, be sure to provide the wire size being used in your MiniStitcher.

Always disconnect the power cord
before any maintenance or adjustments are
made to the MiniStitcher

CAUTION

Replacing Spare Parts

Following are some of the more common wear parts which will need to be removed and replaced in your MiniStitcher. Most replacements require the Stitcher Head to be removed from the MiniStitcher. The instructions on how to remove the head will be given first, then a more specific description for each common wear part will follow.

General Maintenance and Repair (Figure 9)

While some adjustments can be made to the MiniStitcher with the stitcher head in place, most maintenance and general repairs have to be made with the stitcher head removed from the machine.

Cut the wire from the wire spool just below the Wire Guide Spring Bracket (MG10001A).

Pull the remaining wire out from the bottom of the

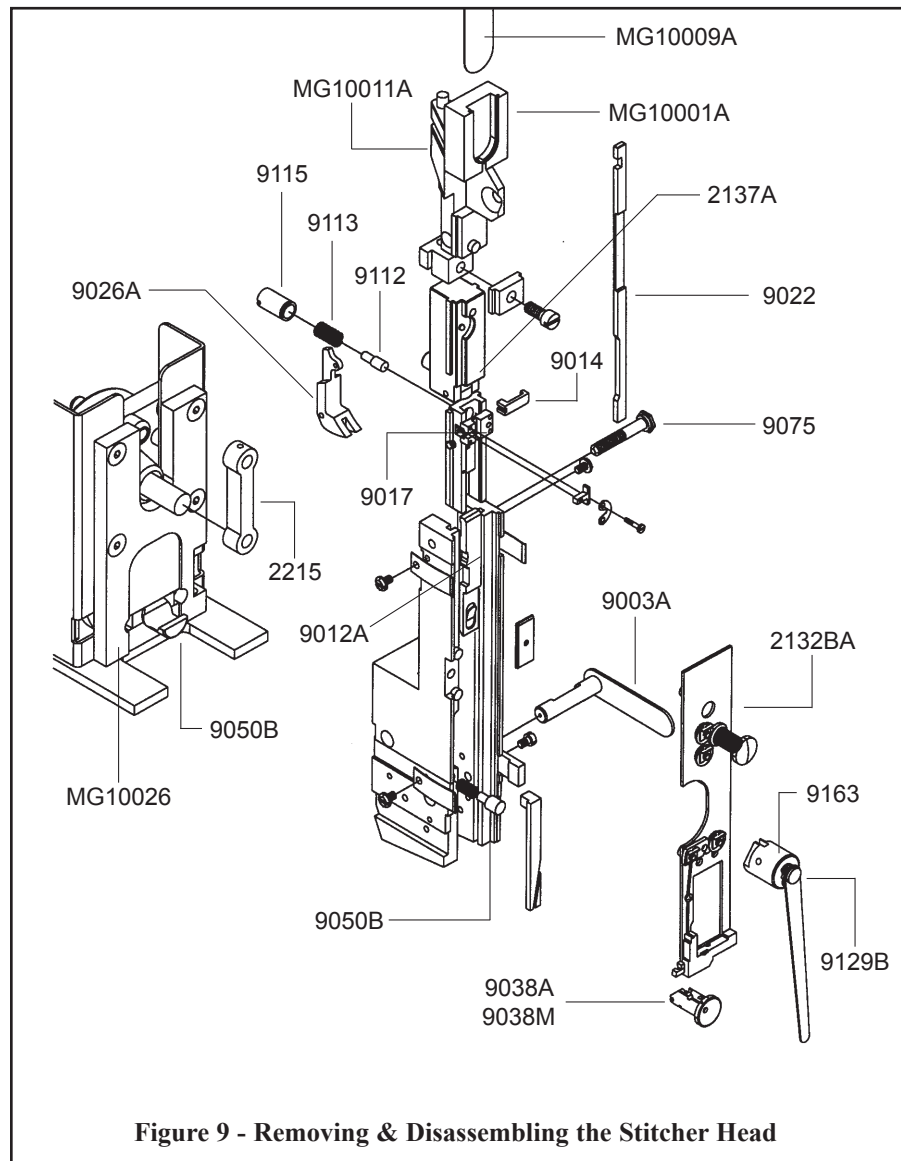

Figure 9 - Removing & Disassembling the Stitcher Head

stitcher head. Remove the Wire Guide Spring (MG10009A) from the Wire Guide Spring Bracket (MG10001A).

Loosen the Bonnet Clamp Eccentric Handle (9003A) and remove the Stitcher Head from the MiniStitcher. Place the Head on a clean work area. Be aware that the Driving Shaft Connection Link (2215) is removed from either the Driving Slide Assembly (2137A) or the Crank (MG10031A).

Always disconnect the power supply before assembling the MiniStitcher or making any adjustments.

CAUTION

Removing and Replacing the Wire Cutters (Figure 10)

The Wire Cutters (9048) have two cutting surfaces, each of which may be used by reversing the ends and positioning in the Face Plate (2132BA). To change or reverse the Wire Cutters, they must be removed from the Face Plate. Loosen the Screws (UA2305.2) in the Face Plate Clips (9056) and the Screw (0084) in the Solid Face Plate Clip (9171). Once the clips are

loosened, the Face Plate can be tilted away from the Bonnet (2601R) to remove the Wire Cutters. Slide the existing or new Wire Cutters into the cutter holder in the Face Plate - with the tongue

of the upper cutter facing the front and the tongue of the lower cutter facing the back and into the Wire Cutter Operating Slide groove. Before tightening the Face Plate Clip Screws (UA2305.2) and the Solid FacePlate Clip Screw (0084), make sure that each Cutter has slipped into position in the Face Plate and in the Wire Cutter Operating Slide. (9049) Press the Face Plate under the Face Plate Clips and tighten the Face Plate Clip Screws. Always rotate the MiniStitcher manually before switching the power on to ensure free mechanical movement. This will prevent serious damage to the Head.

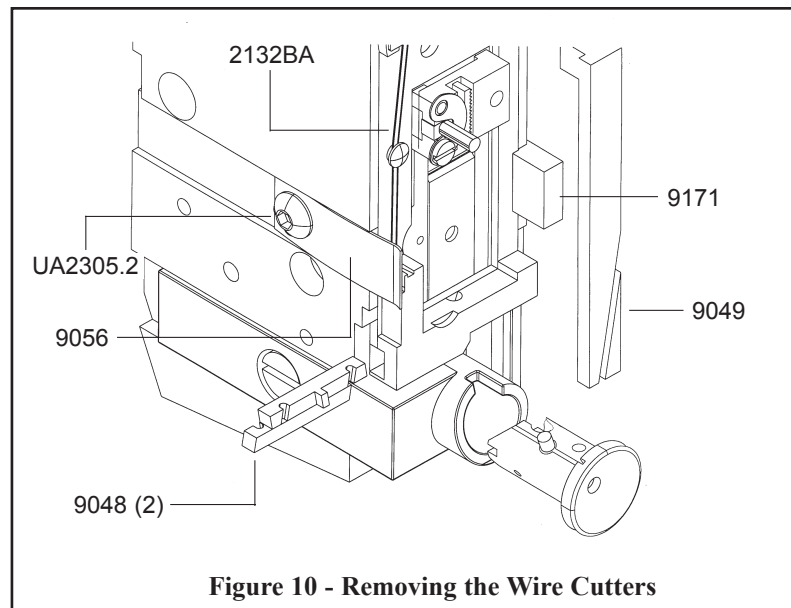

Figure 10 - Removing the Wire Cutters

Removing and Replacing the Grip (Figure 11)

The Grip (9015) can be used in two positions so that when the gripping teeth show signs of wear, it may be reversed to extend the life of the part. Loosen the Grip Retaining Clip Screw (9024) and swing the Grip Retaining Clip (9023) out of the way. Remove the Grip and reverse its position within the Grip Holder. If both edges are worn, replace the part. Return the Grip Retaining Clip to its original position and tighten the Grip Retaining Clip Screw.

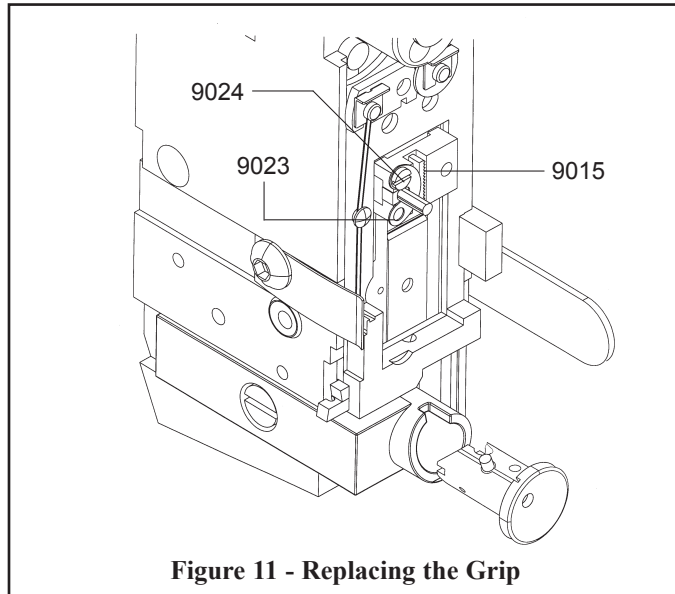

Figure 11 - Replacing the Grip

Always disconnect the power supply before assembling the StitchMaster or making any adjustments.

CAUTION

Removing and Replacing the Tension Pawl (Figure 12)

The Tension Pawl (9098) is double-ended so that when one end is worn, it can be reversed, increasing the life of the part by providing a new gripping surface. To remove the Tension Pawl, disengage the Tension Pawl Spring (9134) from the Tension Pawl and remove the Wire Straightener Roll Clip (9124). Flip the Tension Pawl over so that a new surface is in contact with Wire Straightener Roller (9103) and replace the E-clip. Make sure that the Tension Pawl is under the flange in the Wire Straightener Roll before re-engaging the Tension Pawl Spring. If both sides of the Pawl are worn, replace the part.

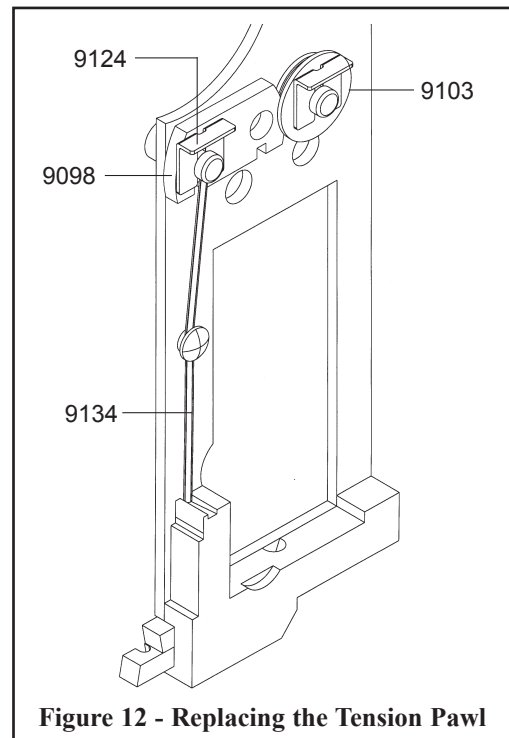

Figure 12 - Replacing the Tension Pawl

Removing and Replacing the Driver (Figure 13)

The Driver (9009-25 or 9009-21x25) is also double-ended so that when it is worn, it can be reversed to provide a new driving surface and increase the life of the part. The Driver can be removed and replaced without having to remove the Head from the StitchMaster. Rotate the Shaft Extension Handle (PG10211) manually until the Driver is at the top of its stroke. Insert the supplied Driver Release Pin (5160) into the hole in the Driver. This will depress the Driver Retaining Spring (9010) so that you will be able to push the Driver down along the Bender Bar (9013BA-25 or 9013BA-21x25) until it can be pulled out from the bottom of the Head.

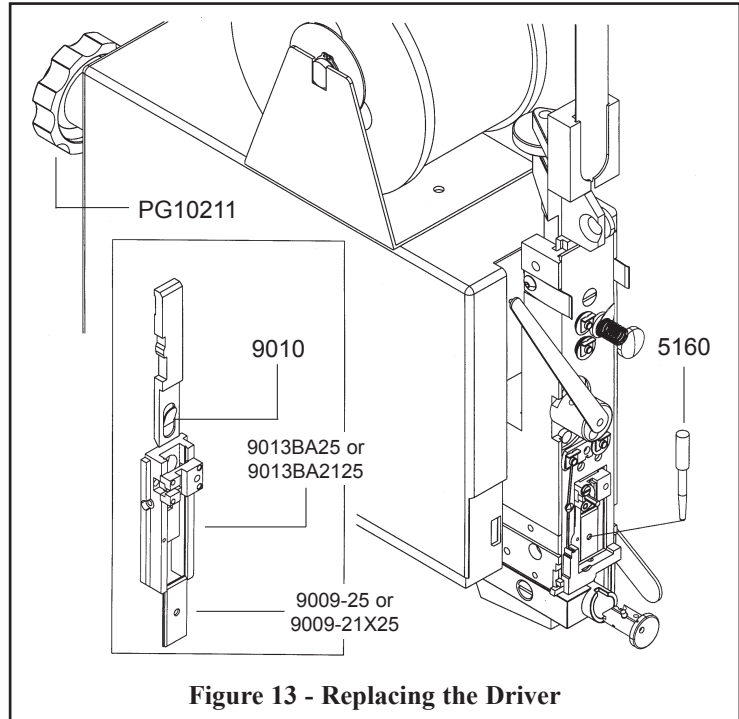

Figure 13 - Replacing the Driver

Either reverse the existing Driver or replace it with a new one. Slide the Driver back up through the Bender Bar until you hear the Driver Retaining Spring click, indicating that the Driver is in its correct position.

Changing the Solid Clincher (Figure 14)

When worn, the Solid Clincher (MG10178) will need to be replaced. Raise the plastic Head Guard (PG10003) and loosen and remove the Screw (UA4808.3), the Lock Washer (CB371A) and the Plain Washer (PW10.3) so that the Solid Clincher can be removed from the Clincher Arm. Replace the Solid Clincher and loosely secure it with the Washer and Screw. There are two (2) leveling Screws (UA2804.6) which come up through the bottom of the Clincher Arm which may have to be adjusted.

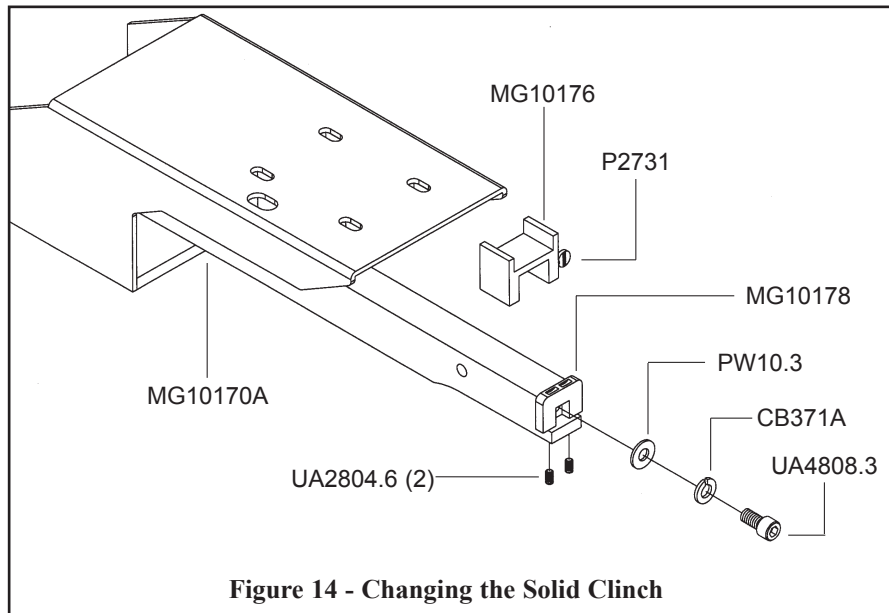

Figure 14 - Changing the Solid Clinch

Manually turn the

MiniStitcher over until the Driver (9009-25 or 9009-21x25) is at the lowest position of its stroke. Adjust the leveling Screws so that the Solid Clincher is brought up level with the bottom of the Driver. Center the Solid Clincher under the Driver and tighten the Screws (UA4808.3).

Always disconnect the power supply before assembling the MiniStitcher or making any adjustments.

CAUTION

Replacing the Stitcher Head (Figure 9)

Once the replacement parts have been installed or the existing wear parts have been reversed, the Stitcher Head can be mounted back on the MiniStitcher. The following steps will make the process easier: Make sure the upper end of the Driving Shaft Connection Link (2215) is attached to the Crank (MG10031A) with the oil hole up and the lower end is attached to the Driving Slide Pin (2103B). Position the Bonnet Clamp Eccentric (9003A) at an 11:00 position and slide the Head onto the Bonnet Clamp Block (9002) against the Head Mounting Plate (MG10026). Once the Head is lined up, pull the Bonnet Clamp Eccentric down, to approximately a 9:00 position, or until the Head is firmly fastened.

Modifications

Timing (Figure 15)

The timing in a MiniStitcher determines the knock-off point of the Crank (MG10031A). The timing is set before the MiniStitcher leaves the factory, but the following instructions can be used if the timing has to be changed or re-adjusted. The end of the Crank without the Screw (CB651) should stop at a position comparable to 11:00 or 12:00 o'clock on a face of a clock. To adjust this position, loosen the Screw (PG10326) in the Control Cam (MG10032) and rotate it in the direction opposite of the way the Crank needs to move so that it stops between 11:00 and 12:00 o'clock. **NOTE: A clockwise rotation will result in an earlier knock-off point while a counter-clockwise rotation will result in a later knock-off point.** Trip the MiniStitcher to double-check the ending position of the Crank. Remember to tighten the Screw (PG10326) after the adjustments have been made.

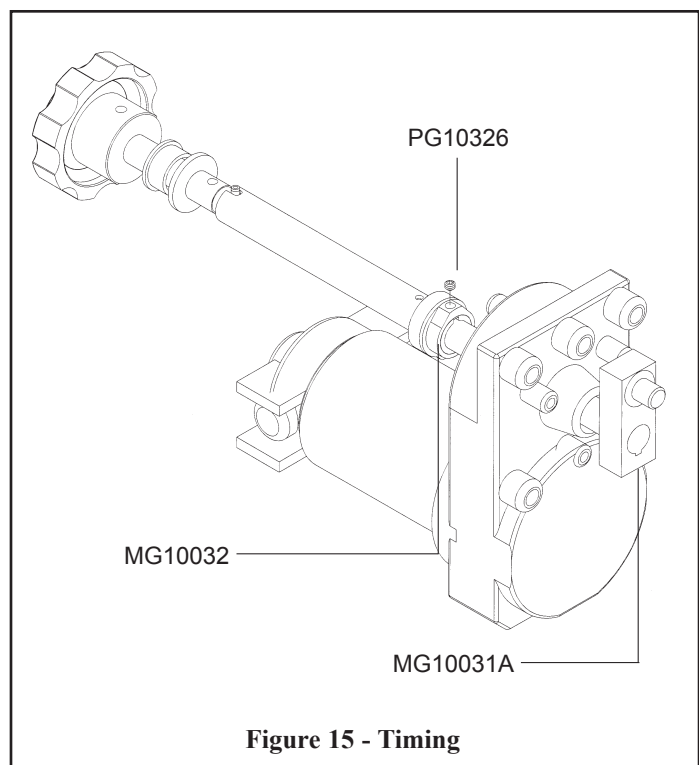
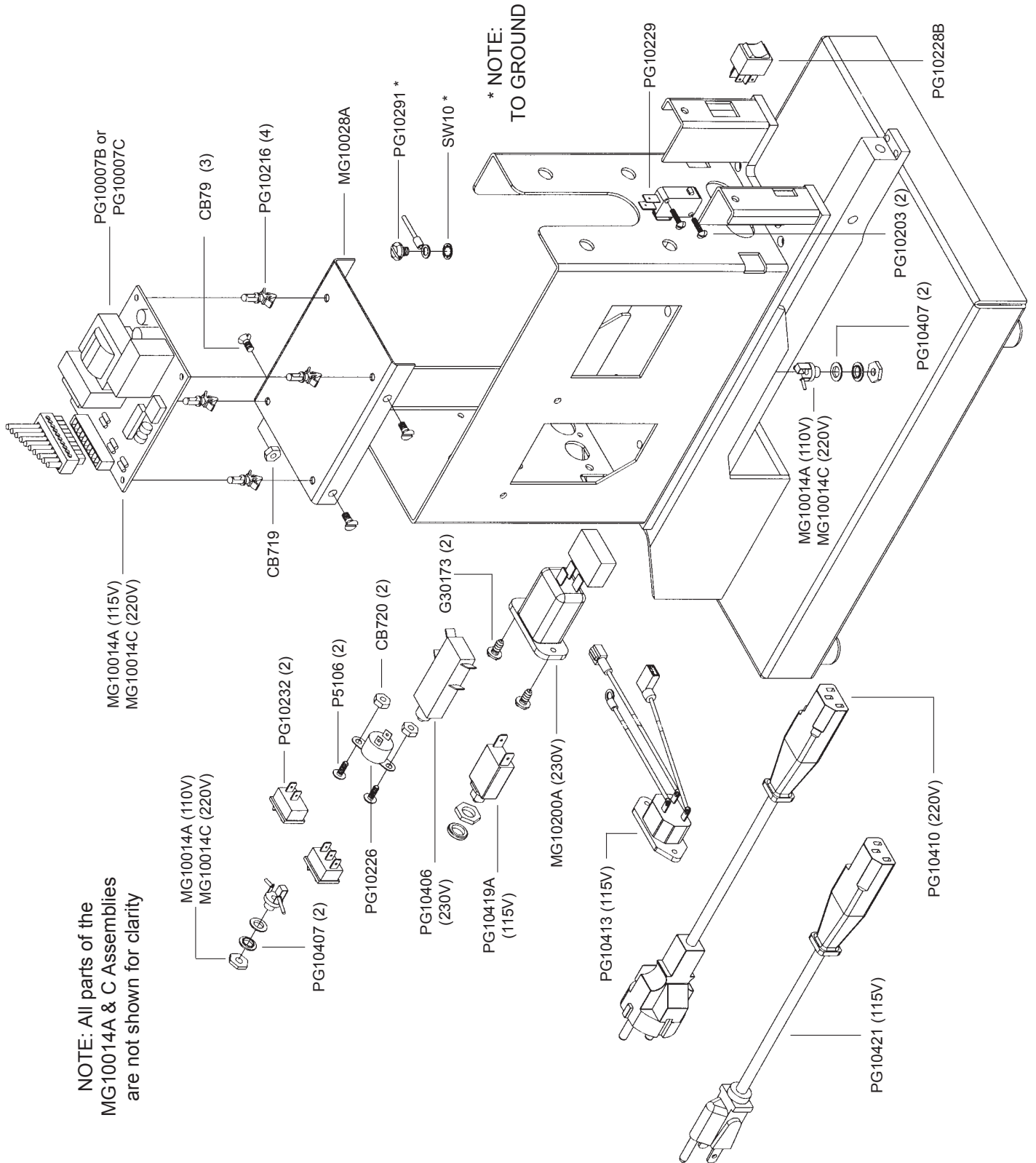

Figure 15 - Timing

Frame Assembly

NOTE: PG10021
FOR 115V ONLY
Include instruction sheet DBSSMMOV with PG10021
for field upgrades - MG10014A (115V) ONLY.

NOTE: All parts of the
MG10014A & C Assemblies
are not shown for clarity



Frame Assembly

PART No.	DESCRIPTION	QUANTITY
G30173	Self Tap Screw 8 x 3/8	2
MG10014A	Wiring Assembly (115V)	1
MG10014C	Wiring Assembly (230V)	1
MG10028A	Circuit Board Platform	1
MG10200A	Power Kit - C.E.	1
CB719	Nut 8-32	1
P5106	Screw 6-32 x 3/8	2
CB720	Nut 6-32	2
PG10007B	Circuit Board (110V)	1
PG10007C	Circuit Board - CE (220V)	1
PG10203	Screw 4-40 x 1/2	2
PG10216	Circuit Board Spacer	4
PG10226	Cordset, Phone Plug	1
PG10228B	On/Off Switch	1
PG10229	Snap Switch	1
PG10232	Trip Mode Switch	2
PG10291	Screw 10-24 x 1/4	1
PG10406	Circuit Breaker 2 Pole	1
PG10407	Shoulder Washer 1/4 (230V only)	4
PG10410	Power Cord, Euro (220V)	1
PG10413	Plug Receptacle	1
PG10419A	Circuit Breaker 1 Pole	1
PG10421	Power Cord (115V)	1
SW10	Lock Washer	1
CB79	Screw 8-32 x 3/8	3

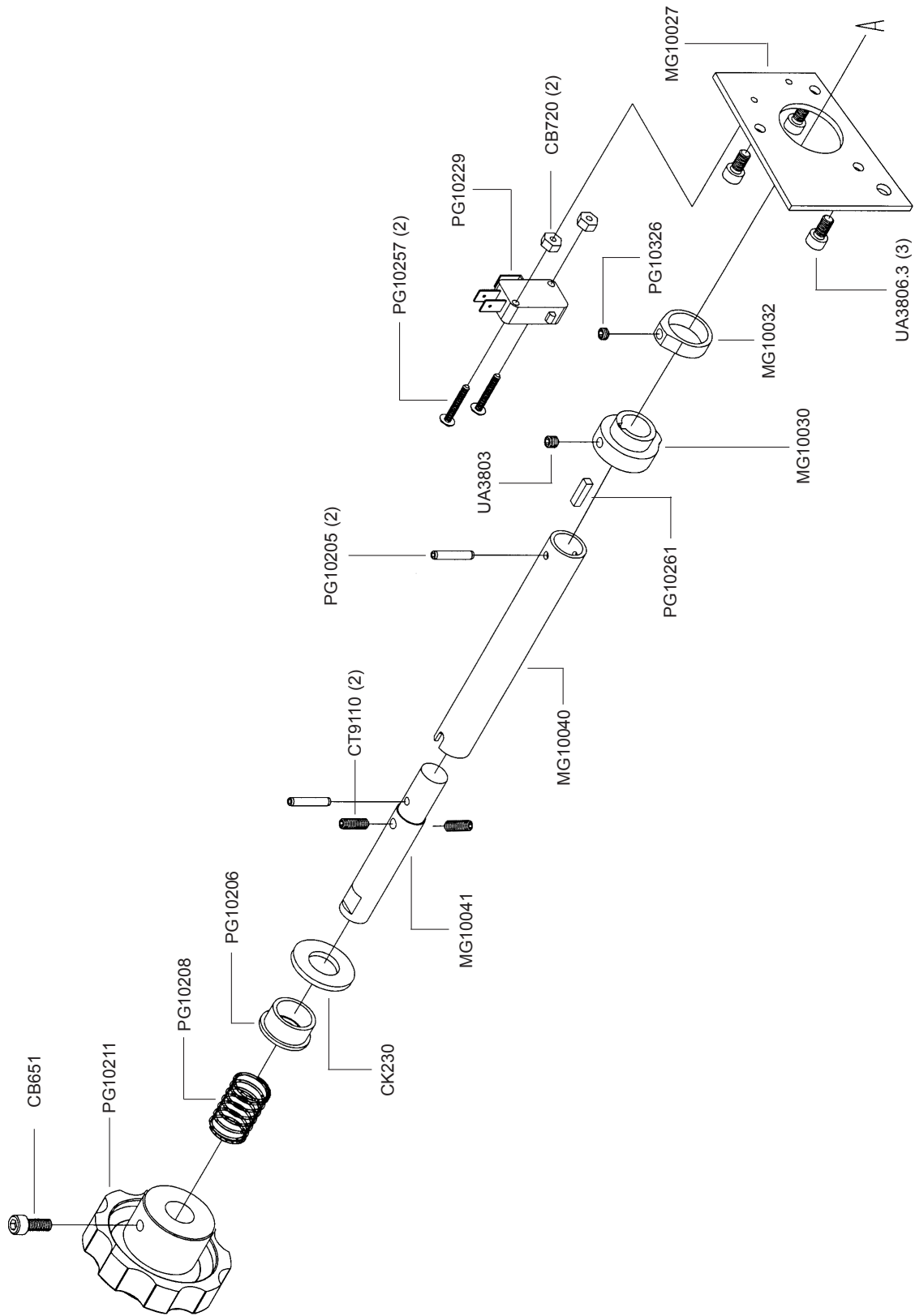

Cam Switch Assembly

PART No.	DESCRIPTION	QUANTITY
MG10027	Cam Switch Mounting Plate	1
MG10030	Clincher Cam	1
MG10032	Control Cam	1
MG10040	Shaft Extension Tube	1
MG10041	Shaft Extension	1
CK230	Washer 1/2	1
CB720	Nut 6 - 32	2
PG10205	Spirol Pin 1/8 x 3/4	2
PG10206	Nylon Bushing 9/16	1
CT9110	Screw 8 - 32 x 1/2	2
PG10208	Shaft Extension Spring	1
PG10211	Shaft Extension Handle	1
PG10229	Snap Switch	1
PG10257	Cam Switch Screw	2
PG10261	Square Key 1/8 x 1/2	1
PG10326	Screw 8 - 32 x 1/8	1
UA3803	Screw 10 - 32 x 3/16	1
UA3806.3	Screw 10 - 32 x 3/8	3
CB651	Screw 10 - 32 x 1/2	1

The MiniStitcher

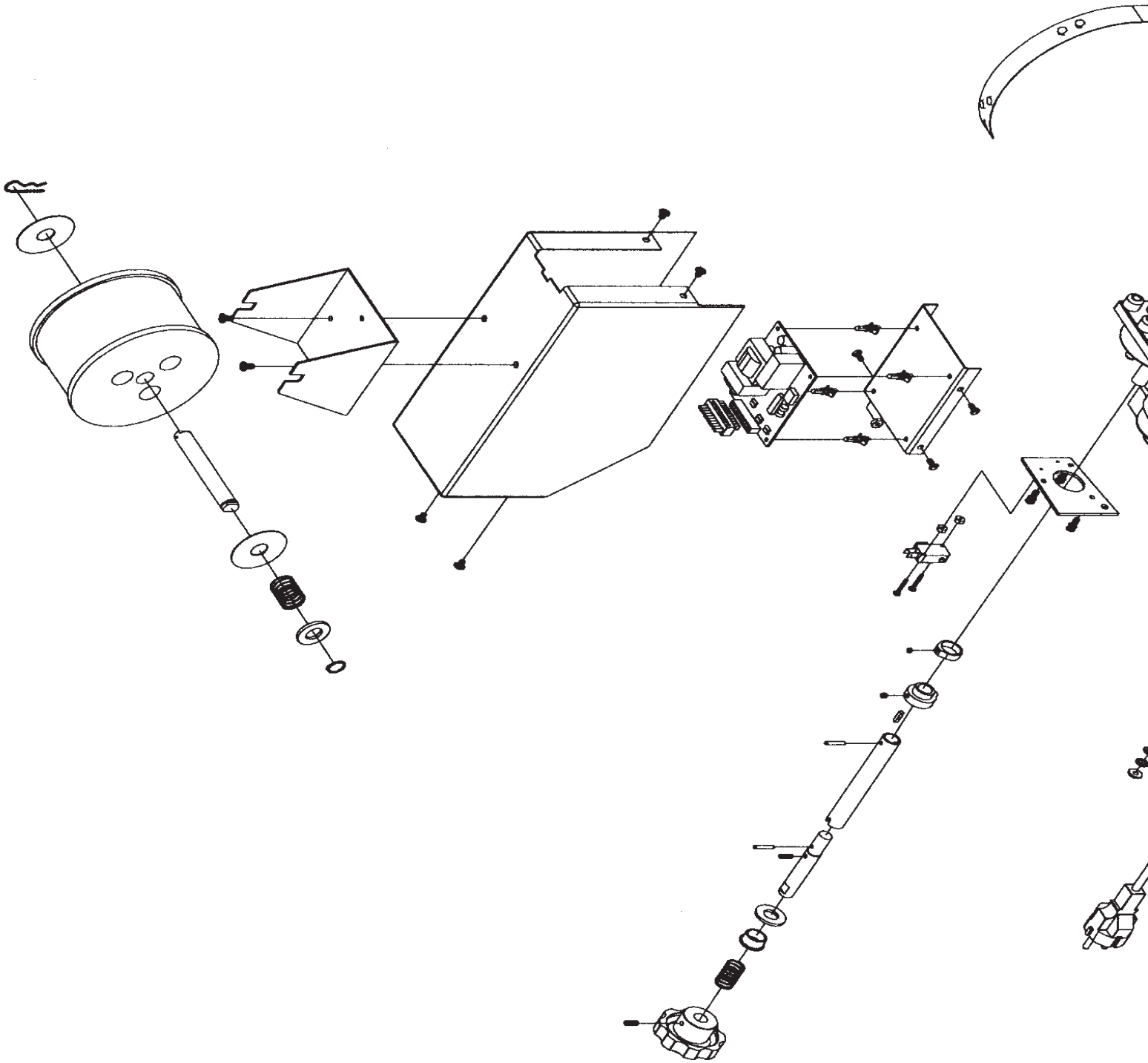

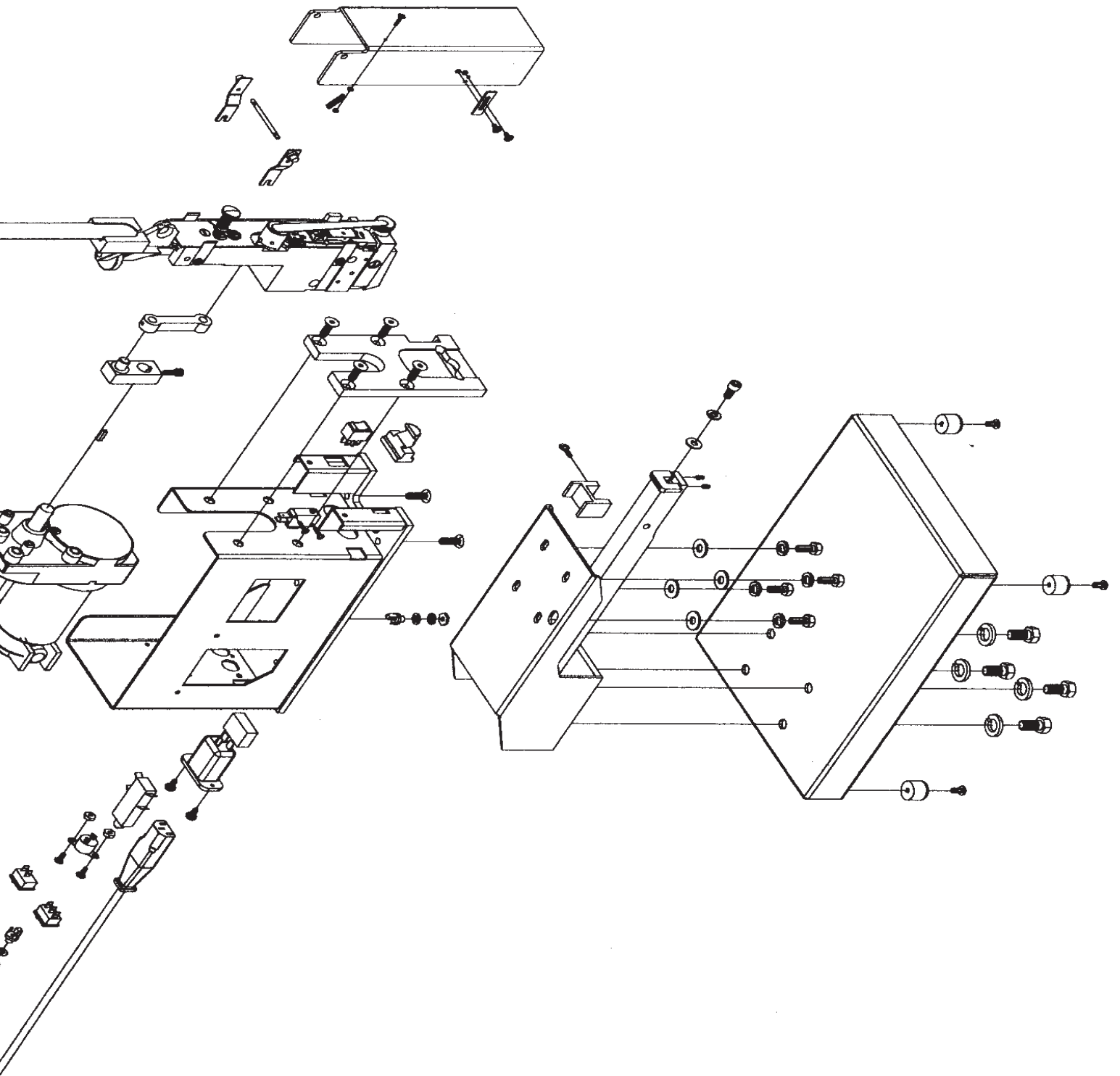

Gear Motor Assembly

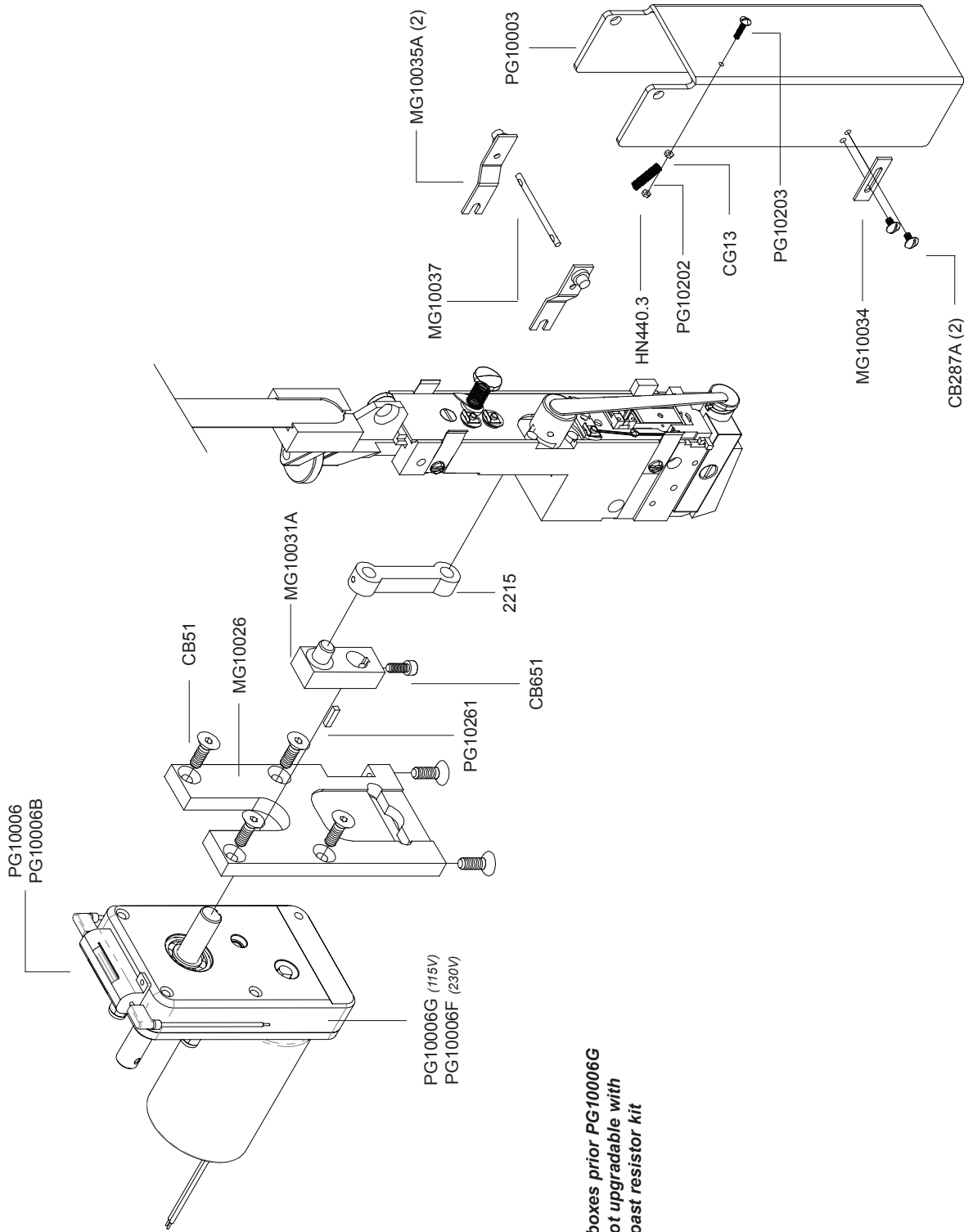

NOTE:
 Gearboxes prior PG10006G
 are not upgradable with
 anticoast resistor kit

Gear Motor Assembly

PART No.	DESCRIPTION	QUANTITY
2215	Driving Shaft Connection Link	1
HN440.3	Nylon Insert Lock Nut	1
CG13	Hex Nut	1
MG10026	Head Mounting Plate	1
MG10031A	Crank Assembly	1
MG10034	Safety Trip	1
MG10035A	Guard Arm Assembly	2
MG10037	Guard Spring Rod	1
PG10003	Head Guard	1
PG10006	Gear Motor (115V)	1
PG10006B	Gear Motor (220V)	1
PG10202	Tension Spring	1
PG10203	Screw 4 - 40 x 1/2	1
PG10261	Square Key 1/8 x 1/2	1
PG10289	Brush Assembly	1
PG10290	Brush Holder	1
CB287A	Safety Trip Screw	2
CB651	Screw 10 - 32 x 1/2	1
CB51	Screw 1/4 - 20 x 3/4	6

Platform Assembly

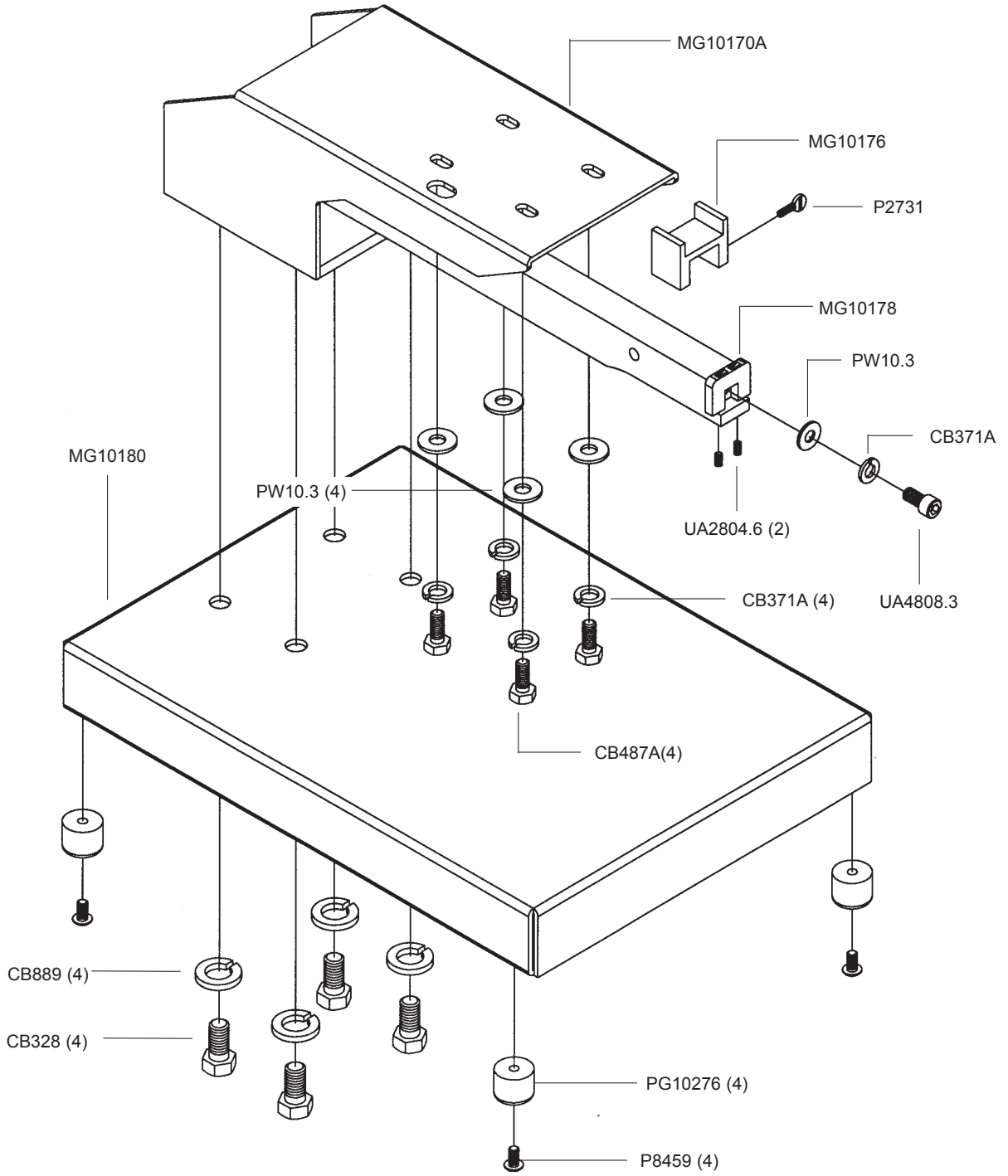

Platform Assembly

PART No.	DESCRIPTION	QUANTITY
CB371A	Lock Washer 1/4	5
CB889	Lock Washer 3/8	4
MG10170A	Platform Weldment	1
MG10176	Backstop	1
MG10178	Solid Clincher	1
MG10180	Table Base	1
P2731	Thumb Screw 1/4-20 x 3/4	1
P8459	Tap Screw 10-24 x 1/2	4
PG10276	Rubber Bumper 3/4 OD	4
PW10.3	Washer 3/16	5
UA2804.6	Screw 8-32 x 3/8	2
CB487A	Screw 1/4-20 x 5/8	4
UA4808.3	Screw 1/4-20 x 1/2	1
CB328	Screw 3/8-16 x 1	4

Tables and Trip Assemblies

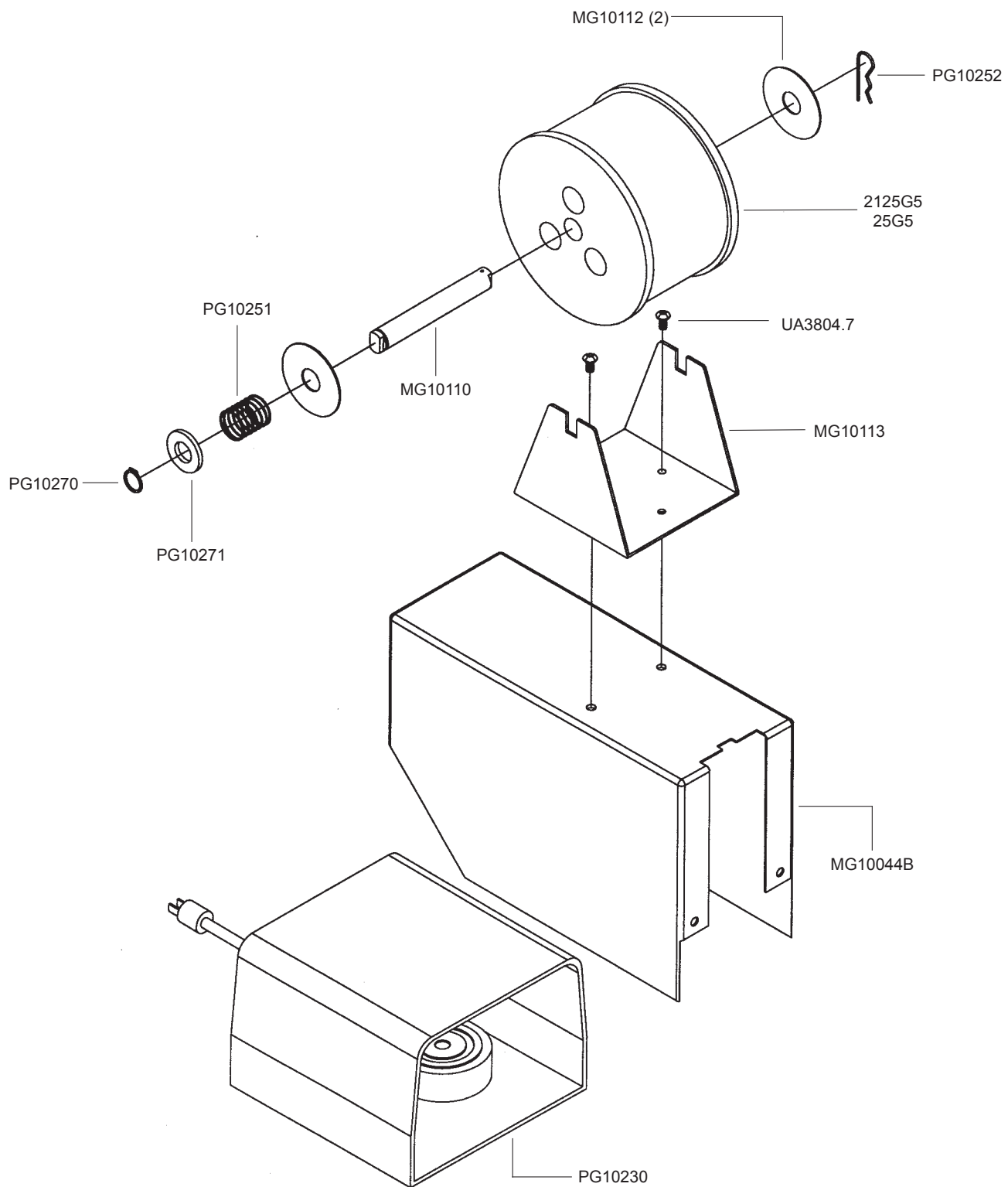

Wire, Table and Trip Assemblies

PART No.	DESCRIPTION	QUANTITY
2125G5	Wire Spool 21x25 Flat	1
25G5	Wire Spool 25 Gauge Round	1
MG10044B	Cover	1
MG10110	Spool Shaft	1
MG10112	Wire Spool Washer	2
MG10113	Wire Spool Cradle	1
PG10230	Foot Switch with Guard	1
PG10251	Spool Friction Spring	1
PG10252	Spool Clip	1
PG10270	Retaining Ring	1
PG10271	Washer 9/16	1
UA3804.7	Screw 10-32 x 1/4	2

The 26 Stitcher Head - Bonnet Assembly

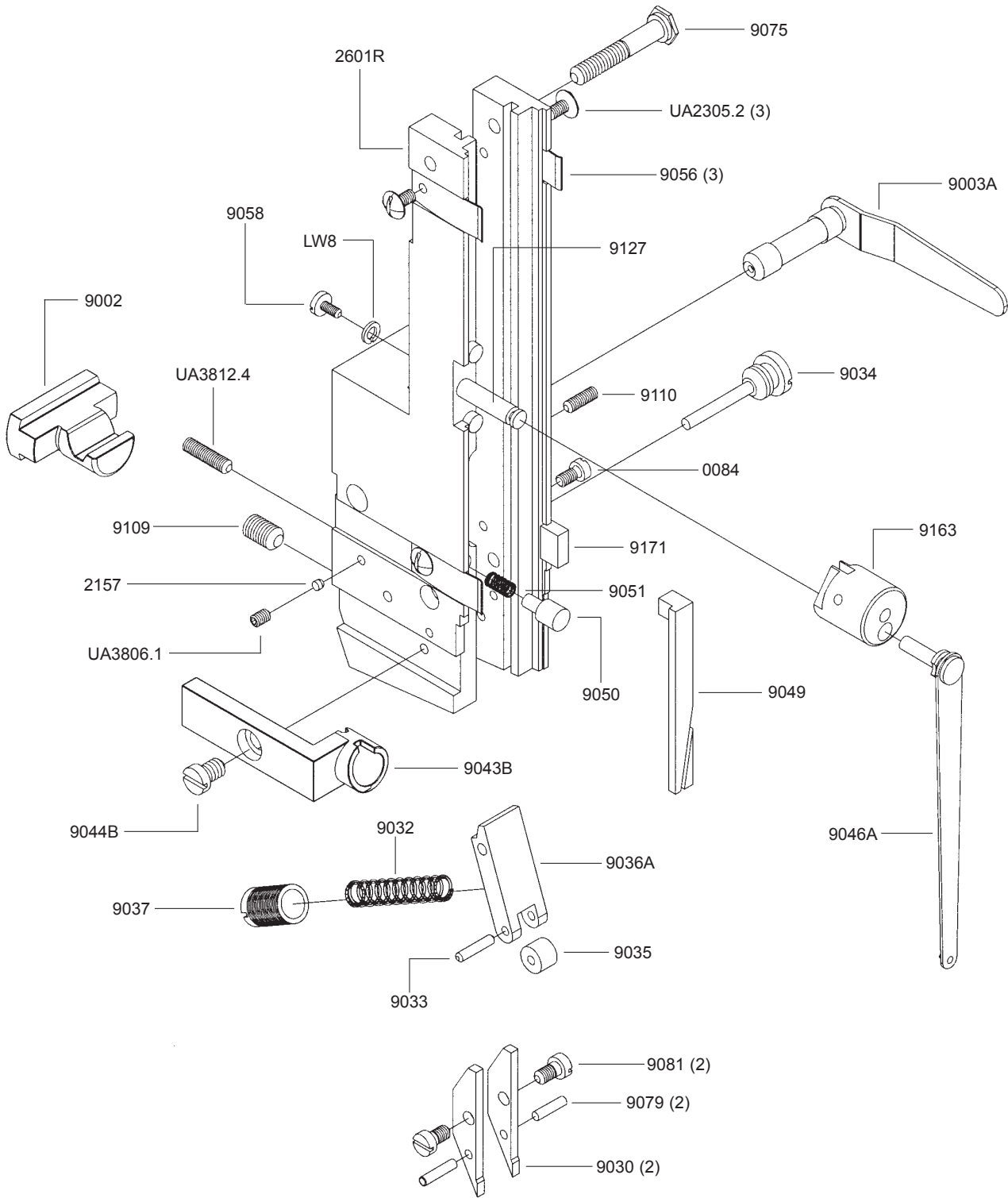

The 26 Stitcher Head - Bonnet Assembly

PART No.	DESCRIPTION	QUANTITY
0084	Solid Face Plate Clip Screw	1
2157	Supporter Lever Lock Shoe	1
2601R	Bonnet Sub Assembly	1
9002	Bonnet Clamp Block	1
9003A	Bonnet Clamp Handle	1
9030	Supporter Guide Plate	2
9032	Supporter Spring	1
9033	Roll Pin	1
9034	Supporter Spring Lever Screw	1
9035	Supporter Spring Lever Roll	1
9036A	Supporter Spring Lever Assembly	1
9037	Supporter Spring Lever Bushing	1
9043B	Swivel Holder	1
9044B	Swivel Holder Screw	1
9046A	Swivel Operating Spring	1
9049	Wire Cutter Operating Slide	1
9050	W/C Operating Slide Friction Plug	1
9051	W/C Operating Slide Friction Spring	1
9056	Face Plate Retaining Clip	3
9058	Swivel Operating Lever Screw	1
9075	Wire Guide Spring Bracket Screw	1
9079	Supporter Guide Plate Dowel	2
9081	Screw	2
9109	Bonnet Alignment Screw	1
9110	Bonnet Screw Binder	1
9127	Swivel Operating Lever Stud	1
9163	Swivel Operating Hub	1
9171	Solid Face Plate Clip	1
LW8	Lock Washer	1
UA2305.2	Face Plate Retaining Clip Screw	3
UA3806.1	Supporter Lever Lock Screw	1
UA3812.4	Supporter Lever Stop Screw	1

The 26 Stitcher Head - Face Plate Assemblies

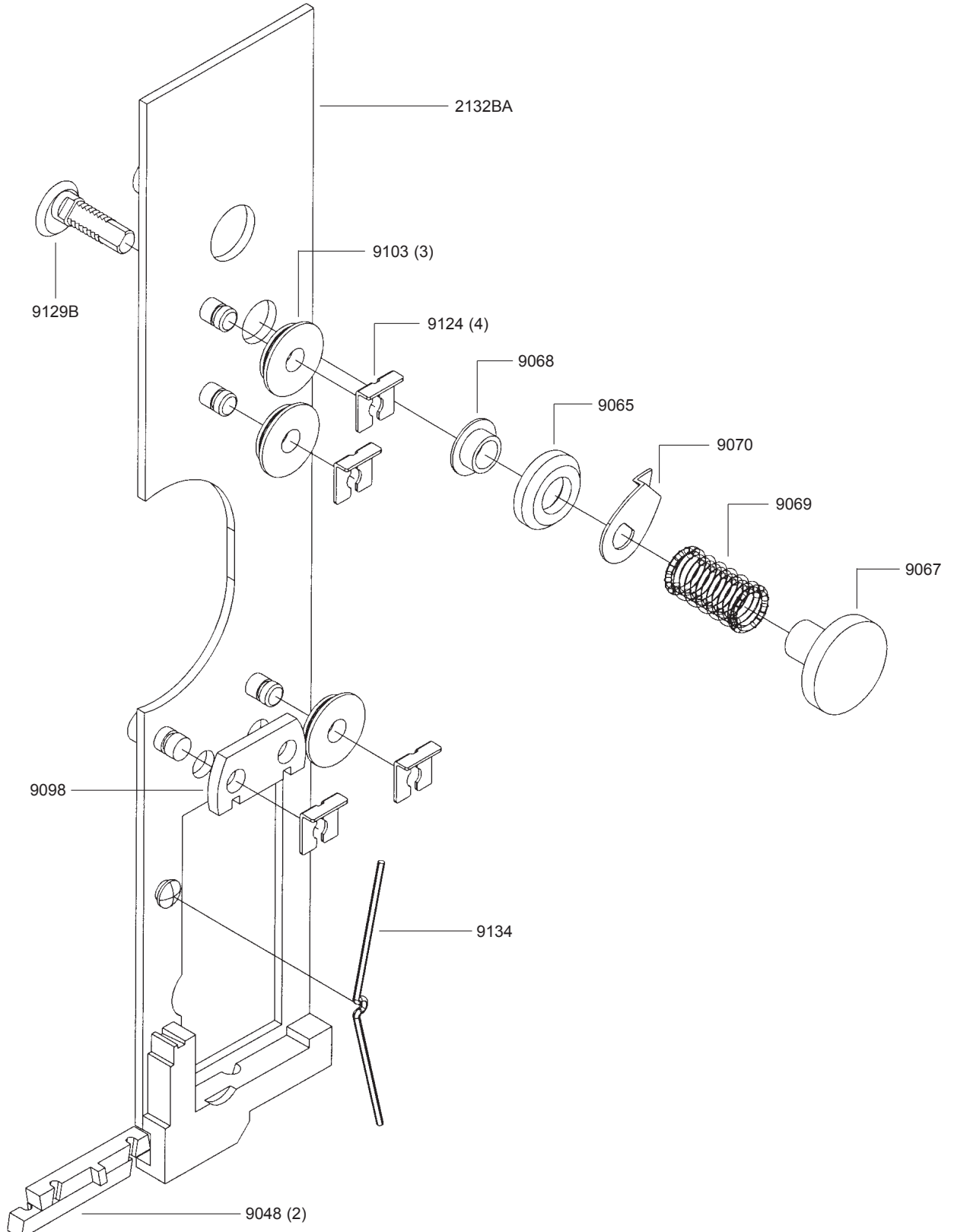

The 26 Stitcher Head - Face Plate Assemblies

PART No.	DESCRIPTION	QUANTITY
2132BA	Face Plate	1
9048	Wire Cutter	2
9065	Wire Straightener Eccentric Roller	1
9067	Wire Straightener Eccentric Nut	1
9068	Wire Straightener Eccentric Bushing	1
9069	Wire Straightener Eccentric Spring	1
9070	Wire Straightener Eccentric Pointer	1
9098	Tension Pawl	1
9103	Wire Straightener Roller	3
9124	Wire Straightener Roller Clip	4
9129B	Swivel Operating Spring Stud	1
9134	Tension Pawl Spring	1

The 26 Stitcher Head - Sub Assemblies

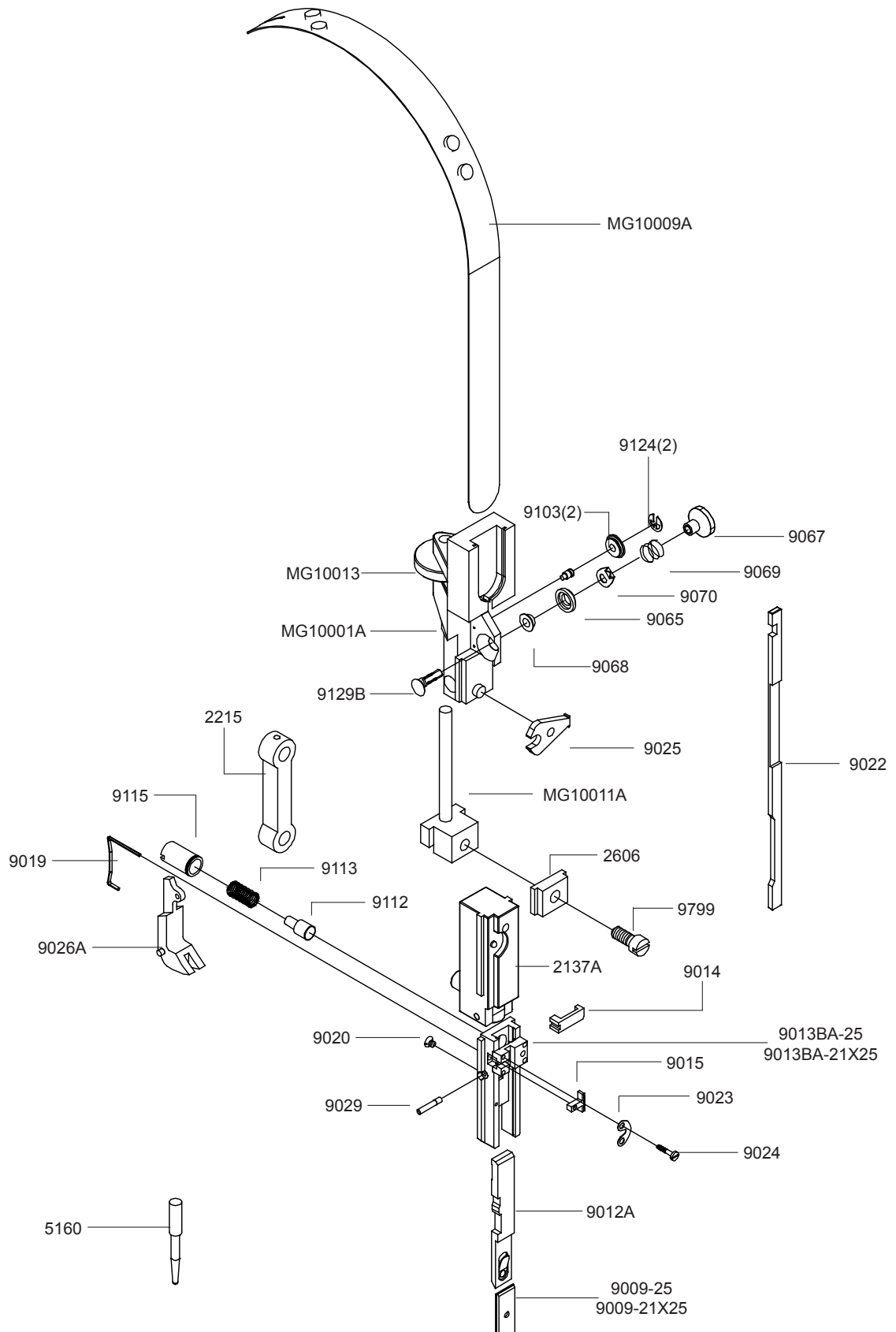

The 26 Stitcher Head - Sub Assemblies

PART No.	DESCRIPTION	QUANTITY
2137A	Driving Slide Assembly Link	1
2215	Driving Shaft Connection Link	1
2606	Face Plate Lock Clamp	1
5160	Driver Release Pin	1
9009-25	Driver	1
9009-21X25		
9012A	Driver Bar Assembly	1
9013BA-25	Bender Bar	1
9013BA-21X25		
9014	Latch	1
9015	Grip	1
9019	Grip Spring	1
9020	Grip Spring Retaining Screw	1
9022	Grip Release Slide	1
9023	Grip Retaining Clip	1
9024	Grip Retaining Clip Screw	1
9025	Grip Release Slide Lever	1
9026A	Supporter Assembly	1
9029	Supporter Pivot Pin	1
9065	Wire Straightener Eccentric Roller	1
9067	Wire Straightener Eccentric Nut	1
9068	Wire Straightener Eccentric Bushing	1
9069	Wire Straightener Eccentric Spring	1
9070	Wire Straightener Eccentric Pointer	1
9103	Wire Straightener Roller	2
9112	Bender Bar Friction Plug	1
9113	Bender Bar Friction Spring	1
9115	Bender Bar Friction Bushing	1
9124	Wire Straightener Roller Clip	2
9129B	Swivel Operating Spring Stud	1
9799	Face Plate Locating Screw	1
MG10001A	Wire Guide Spring Bracket Assembly	1
MG10009A	Wire Guide Spring Assembly	1
MG10011A	Face Plate Adjustment Slide Assy.	1
MG10013	Face Plate Adjustment Nut	1

Internal Wiring Schematic

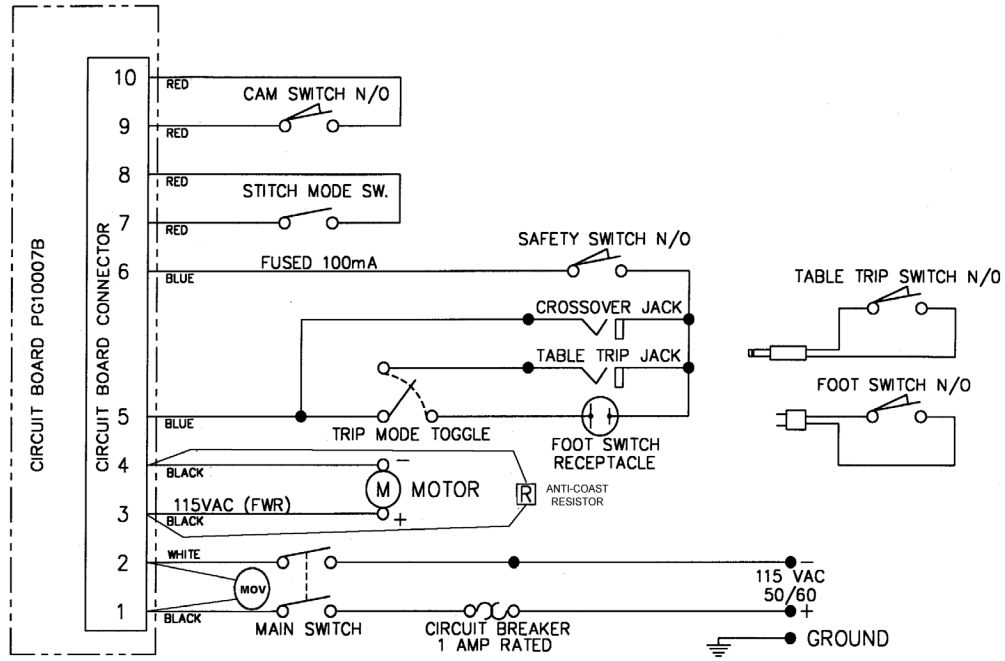

MODEL: IMS-A

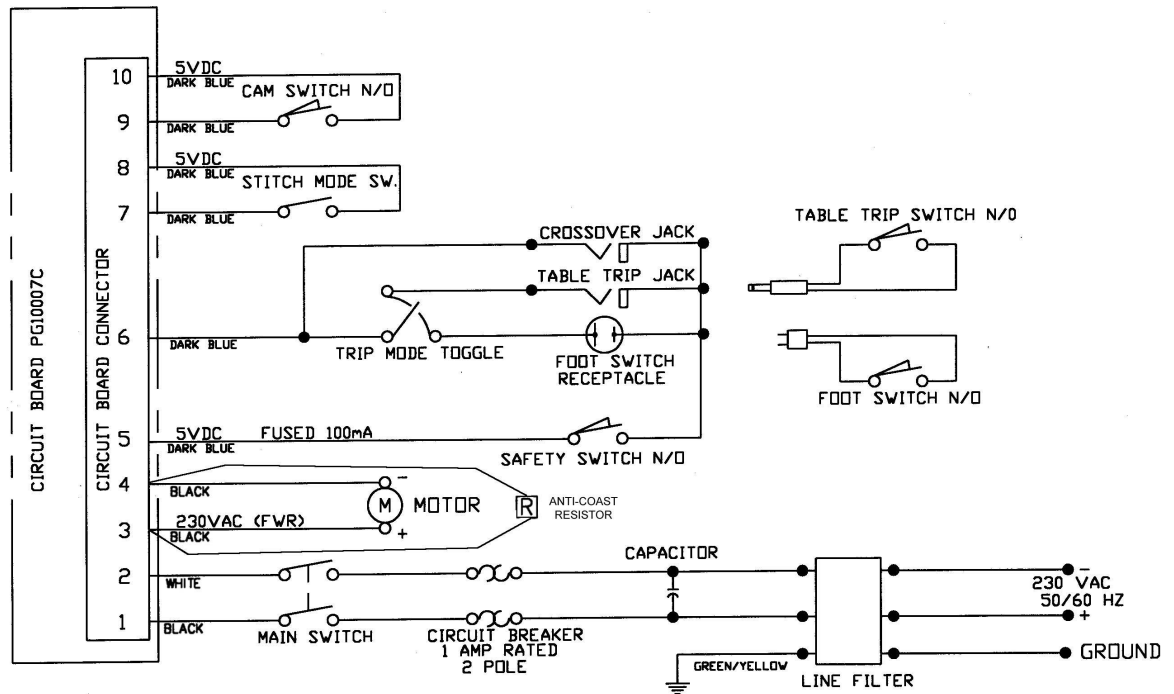

MODEL: IMS-CE

Part Number / Description Cross-Reference

ITEM NO.	DESCRIPTION	QUANTITY	ITEM NO.	DESCRIPTION	QUANTITY
0084	Solid Face Plate Clip Screw	1	9035	Supporter Spring Lever Roll	1
2001ASMHD251/2	MiniStitcher Head	1	9036A	Supporter Spring Lever Assembly	1
20ASMHD	MiniStitcher Head	1	9037	Supporter Spring Lever Bushing	1
2103B	Driving Slide Pin	1	9038A	Swivel Assembly	1
2110B	Wire Guide Spring Stud	4	9038M	Swivel Assembly - Magnetic	1
2125G5	5lb Wire Spool - Flat	1	9042	Swivel Safety Pin	1
2132BA	Face Plate	1	9043B	Swivel Holder	1
2137A	Driving Slide Assembly Link	1	9044B	Swivel Holder Screw	1
2144	Driving Slide Spring Plunger	1	9046A	Swivel Operating Spring	1
2157	Supporter Lever Lock Shoe	1	9047	Swivel Operating Spring Pin	1
2159	Supporter Spring Screw Washer	1	9048	Wire Cutter	2
2214	Driving Slide Crank Pin	1	9049	Wire Cutter Operating Slide	1
2215	Driving Shaft Connection Link	1	9050	Wire Cutter Oper. Slide Friction Plug	1
2228	Driving Slide Pin Washer	2	9051	Wire Cutter Oper. Slide Friction Spring	1
257	Block Rivet	3	9052	Wire Cutter Operating Slide Stop Pin	1
25G5	5 lb Wire Spool - Round	1	9056	Face Plate Retaining Clip	3
2601R	Bonnet	1	9058	Swivel Operating Lever Screw	1
2606	Face Plate Lock Clamp	1	9059	Swivel Operating Lever Stud	1
2626	Driving Slide Spring	1	9064	Tension Pawl Stud	1
5037	Retaining Clip Rivet	1	9065	Wire Straightener Eccentric Roll	2
5160	Driver Release Pin	1	9066	Wire Straightener Eccentric	2
85199	Ring Terminal	1	9067	Wire Straightener Eccentric Nut	2
850699	Wire Straightener Roll Clip	2	9068	Wire Straightener Eccentric Bushing	2
9002	Bonnet Clamp Block	1	9069	Wire Straightener Eccentric Spring	2
9003A	Bonnet Clamp Handle	1	9070	Wire Straightener Eccentric Pointer	2
9009-25	Driver - 1/2"	1	9075	Wire Guide Spring Bracket Screw	1
9009-21x25	Driver - 1/2"	1	9079	Supporter Guide Plate Dowel	2
9010	Retaining Clip	1	9081	Screw	2
9012A	Driver Bar Assembly - 1/2"	1	9082	Driving Slide Spring Lock Pin	1
9013BA-25	Bender Bar - 1/2"	1	9097	Grip Release Lever Pin	1
9013BA-2125	Bender Bar - 1/2"	1	9098	Tension Pawl	1
9014	Latch	1	9103	Wire Straightener Roller	5
9015	Grip	1	9112	Bender Bar Friction Plug	1
9017	Bender Bar Carriage	1	9113	Bender Bar Friction Spring	1
9019	Grip Spring	1	9115	Bender Bar Friction Bushing	1
9020	Grip Spring Retaining Screw	1	9123	Wire Straightener Roll Stud	5
9022	Grip Release Slide	1	9124	Wire Straightener Roll Clip	4
9023	Grip Retaining Clip	1	9127	Swivel Operating Lever Stud	1
9024	Grip Retaining Clip Screw	1	9129B	Swivel Operation Spring Stud	1
9025	Release Slide Lever	1	9130	Tension Pawl Rivet	1
9026A	Supporter Assembly	1	9132B	Rivet	2
9029	Supporter Pivot Pin	1	9133	Rivet	1
9030	Supporter Guide Plate	2	9134	Tension Pawl Spring	1
9032	Supporter Spring	1	9139	Swivel Operating Stop Pin	2
9033	Roll Pin	1	9140	Swivel Operating Spring Pin Washer	1
9034	Supporter Spring Lever Screw	1	9144C	Wire Cutter Holder	1
			9163	Swivel Operating Hub	1

Part Number / Description Cross-Reference

ITEM NO.	DESCRIPTION	QUANTITY	ITEM NO.	DESCRIPTION	QUANTITY
9164B	Driving Slide Swivel Operating Pin	1	P2934	Lock Washer 1/4"	5
9166	Wire Cutter Locating Pin	1	P4990	Power Cord Strain Release	1
9171	Solid Face Plate Clip	1	P5106	Screw 6-32x3/8	2
9799	Face Plate Locating Screw	1	P6794	Screw 10-24 x 5/8	4
FSK1	Floor Stand	(optional)	CB720	Nut 6-32	2
G30173	Self Tap Screw 8x3/8	2	P7917	Wire Nut (orange)	1
HN440.3	Nylon Insert Lock Nut	1	P8459	Tap Screw 10-24 x 1/2	4
CG13	Hex Nut	1	PG10003	Head Guard	1
IMSK2	Contract Trip Kit	(optional)	PG10006	Gear Motor 115V	1
IMSK3	Work Table Kit	(optional)	PG10006B	Gear Motor -CE 220V	1
CB371A	Lock Washer 1/4	5	PG10007B	Circuit Board (110V)	1
CB889	Lock Washer 3/8	4	PG10007C	Circuit Board - CE (220V)	1
MG10001A	Wire Guide Spring Bracket Assembly	1	PG10017	Face Plate Adjustment Rod Pin	1
MG10006BA	C.E. Motor Assembly	1	PG10200	Weldnut 8-32	2
MG10009A	Wire Guide Spring Assembly	1	PG10202	Tension Spring	1
MG10011A	Face Plate Adjustment Slide Assembly	1	PG10203	Screw 4-40x1/2	3
MG10012	Face Plate Adjustment Rod	1	PG10205	Spirol Pin 1/8x3/4	1
MG10013	Face Plate Adjustment Nut	1	PG10206	Nylon Bushing 9/16	1
MG10014B	Wiring Assembly (110V)	1	CT9110	Screw 8-32x1/2	1
MG10014C	Wiring Assembly - CE (220V)	1	PG10208	Shaft Extension Spring	1
MG10026	Head Mounting Plate	1	PG10211	Shaft Extension Handle	1
MG10027	Cam Switch Mounting Plate	1	PG10216	Circuit Board Spacer	4
MG10030	Clincher Cam	1	PG10220	Straight Terminal 3/16	3
MG10031A	Crank Assembly	1	PG10226	2 Prong Receptacle	1
MG10032	Control Cam	1	PG10227	Phone Jack 141	2
MG10034	Safety Trip	1	PG10228B	On/Off Switch	1
MG10035A	Guard Arm Assembly	2	PG10229	Snap Switch	1
MG10037	Guard Spring Rod	1	PG10230	Foot Switch w/ Guard	1
MG10040	Shaft Extension Tube	1	PG10232	Trip Mode Switch	2
MG10041	Shaft Extension	1	PG10233	Adhesive Wire Clamp	5
MG10044B	Cover	1	PG10234	Circuit Breaker	1
MG10110	Spool Shaft	1	PG10242	Self Lock Pin 3/16x1	2
MG10112	Wire Spool Washer	2	PG10247	Clevis Pin 1/4x1-1/2	1
MG10113	Wire Spool Cradle	1	PG10251	Spool Friction Spring	1
MG10170A	Platform Weldment	1	PG10252	Spool Clip	1
MG10176	Backstop	1	PG10257	Cam Switch Screw	2
MG10178	Solid Clincher	1	PG10259	10 Pin Connector	1
MG10180	Table Base	1	PG10261	Square Key 1/8 x 1/2	2
MG10200A	C.E. Power Kit	1	PG10270	Retaining Ring	1
MG10202A	Receptacle Kit	1	PG10271	Washer 9/16	1
MG10201A	Circuit Breaker Kit	1	PG10276	Rubber Bumper 3/4 OD	4
MG10402	Backstop	1	PG10289	Brush Assembly	1
P2126	Lock Nut Washer 1/4	1	PG10290	Brush Holder	1
CK230	Washer 1/2"	1	PG10291	Screw 10 - 24 x 1/4	1
P2581	Power Cord and Plug	1	PG10292	Terminal 1/16x90	8
P2731	Thumb Screw 1/4-20 x 3/4	1	PG10293	1/8 Hex Nut Wrench	1
CB719	Nut 8-32	1	PG10326	Screw, 8 - 32 x 1/8	2

Part Number / Description Cross-Reference

ITEM NO.	DESCRIPTION	QUANTITY
PG10406	2 Pole Circuit Breaker	1
PG10407	Shoulder Washer 1/4	2
PG10410	Power Cord and Plug	1
PG10411	RFI Filter	1
PG10413	Receptacle	1
PG10418	1/4x90 Degree Terminal	4
PG10419	Circuit Break - 1 Pole	1
PG10421	Power Cord - 115V	1
PW10.3	Washer #10	5
SW10	Lockwasher	1
CB287A	Safety Trip Screw	2
UA2305.2	Face Plate Retaining Clip Screw	3
CB79	Screw 8 - 32 x 3/8	3
UA2804.6	Screw 8-32 x 3/8	2
UA3803	Screw 10 - 32 x 3/16	1
UA3804.7	Screw 10-32x1/4	6
UA3806.1	Supporter Lever Lock Screw	1
UA3806.3	Screw 10 - 32 3/8	3
CB651	Screw 10 - 32 1/2	1
UA3812.2	Screw 10 -32 x 3/4	2
UA3812.4	Supporter Lever Stop Screw	1
CB77A	Screw 1/4 - 20x5/8	4
UA4808.3	Screw 1/4 - 20 x 1/2	1
CB51	Screw 1/4 - 20 x 3/4	6
CB328	Screw 3/8-16 x 11	4
UB2111.2	Supporter Guide Pin	1

Optional Equipment

In addition to the standard features offered with the StitchMaster, optional equipment items can be purchased to better accommodate your stitching needs. The following kits can be purchased from your DeLuxe Stitcher Graphic Arts Representative.

FSK1 (Figure 16)

This heavy duty Floor Stand allows you to place your MiniStitcher wherever it is needed and adjusts from 28" to 42", securely mounting your MiniStitcher. The Floor Stand Kit comes complete with easy to follow instructions and all the parts needed for assembly.

Place the Base Weldment on the floor with the three screw holes up. Use the Leveling Screw (P6110) on the bottom right leg to level the Base. Attach the Post Weldment using the three Screws (P9132) and Lock Washers (LW12.2) provided. Place the Slide Weldment over the Post and lock it into the desired position using the Clamp Handle (MG10155). To finish, attach the four (4) Plugs (PG10267) to the bottom of the Base.

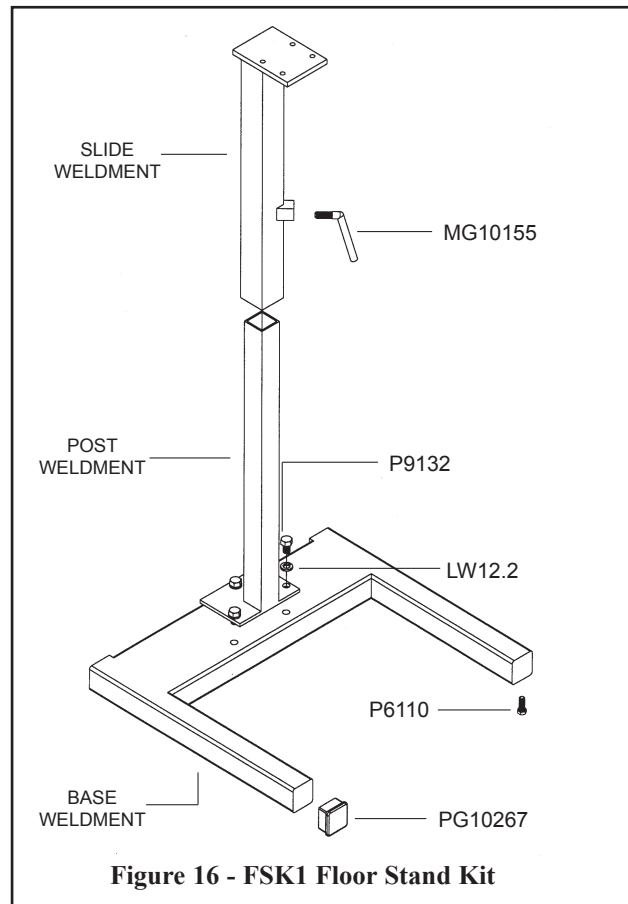

To avoid risk of personal injury never loosen clamp handle unless load on stand is supported.

⚠️ WARNING

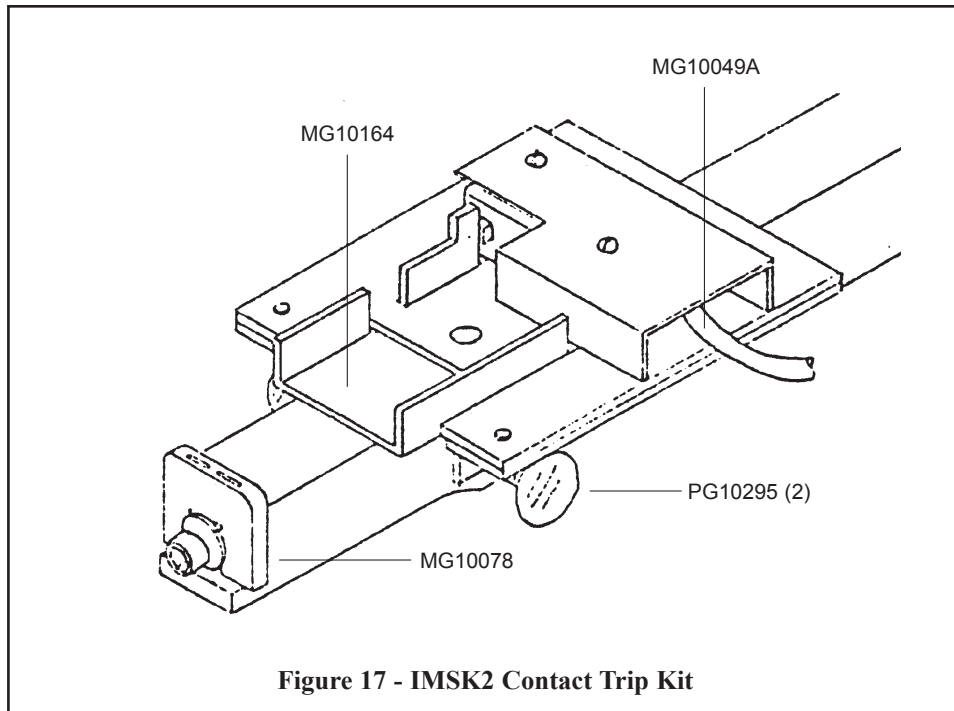

IMSK2 (Figure 17)

For those applications which require it, the Contact Trip Kit (IMSK2) is available for the MiniStitcher. Call your DeLuxe Stitcher Graphic Arts Representative for more information.

The IMSK2 Contact Trip Kit can be mounted directly onto the MiniStitcher. The Kit can also be used in conjunction with the IMSK3 Work Table Kit by following the assembly instructions included with the Work Table Kit.

Loosen the Thumb Screw (P2731) which secures the solid Backstop (MG10176) until the Backstop can be removed from the Clincher Arm. Position the IMSK2 Contact Trip Assembly on the Clincher Arm so that the silver Contact Trip Slide (MG10164) is facing the Solid Clincher Plate (MG10078). Position the Contact Trip Assembly along the length of the Clincher Arm until it fits the application and tighten the two (2) Thumb Screws (PG10295) to secure it.

Plug the Trip Switch Plug Assembly (MG10049A) into the receptacle located on the bottom of

Always disconnect the power cord before assembling the MiniStitcher or making any adjustments.

⚠ CAUTION

the MiniStitcher, along side the Clincher Arm. Make sure the Trip Mode Switch (PG10232), located on the back of the MiniStitcher, is toggled for Contact Trip use and not Foot Switch use.

Plug the Power Cord (PG10421) into a wall outlet and toggle the Power Switch (PG10228B) to the on position. Trip the MiniStitcher by inserting the stock to be stitched under the stitcher head until the stock bumps into the silver Contact Trip Slide and activates the stitcher. If the position of the stitch has to be adjusted, loosen the Thumb Screws in the Contact Trip Assembly and move it until the correct position has been achieved. Be sure to tighten the Thumb Screws to secure this position.

Always disconnect the power cord before assembling the MiniStitcher or making any adjustments.

 **CAUTION**

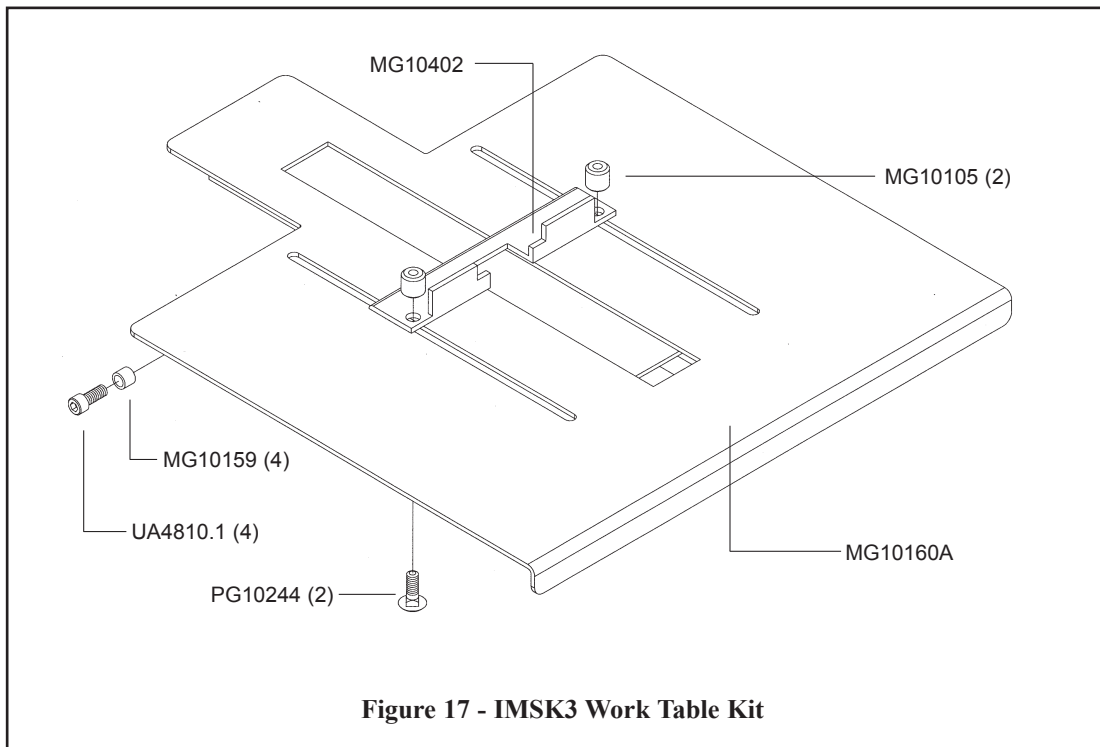

IMSK3 (Figure 18)

For those applications which require it, a Work Table Kit (IMSK3) is available for the MiniStitcher. Call your DeLuxe Stitcher Graphic Arts Representative for more information.

In order to mount the ISMK3 Work Table Kit onto the MiniStitcher, complete the following steps. Remove the Table Base (MG10180) from the bottom of the stitcher by removing the four (4) Screws (UA6116.1) and Washers (LW12.2 and PW14). Lay the stitcher on its side with the Clincher Arm hanging off the edge of a table. Slide the Work Table (MG10160A) over the Clincher Arm from the front until the Solid Clincher (MG10178) is aligned with the rectangular hole in the Table. The slots in the Work Table should also align with the threaded holes in the Clincher Arm. Place each of the four (4) Screws (UA4810.1) provided through the slot, through the Spacer (MG10159) and into the Clincher Arm. Before tightening these Screws, raise the Table until it is even with the top of the Solid Clincher and it is level.

CAUTION
 Always disconnect the power cord before assembling the MiniStitcher or making any adjustments.

REGISTRATION

To better service your wire stitching needs, please take a moment to fill out and return this registration card.

CUSTOMER

Name : _____
(First) (Middle Initial) (Last)
Company : _____
Street Address : _____
City : _____ State/Province : _____ Zip : _____
Country : _____
Phone : _____ Fax : _____ E-mail : _____

PRODUCT

Machine(s) Purchased : _____
Serial Number(s) : _____
With Head(s) : _____
(Type/Quantity Purchased)
Serial Number(s) : _____
Head(s) Purchased : _____
Serial Number(s) : _____

DEALER

Date Received : _____
Dealer Name : _____
Dealer Street Address : _____
City : _____ State/Province : _____ Zip : _____
Country : _____
Dealer Phone : _____

Other Bindery Products Used : _____

Please take a moment to fill out the attached card and mail it to DeLuxe Stitcher Company, Inc..
In addition, duplicate the information for your records to assist when making further inquiries.

PRODUCT

Machine(s) Purchased : _____
Serial Number(s) : _____
With Head(s) : _____
(Type/Quantity Purchased)
Serial Number(s) : _____
Head(s) Purchased : _____
Serial Number(s) : _____

DELUXE STITCHER GRAPHIC ARTS REPRESENTATIVE

Date Received : _____
Dealer Name : _____
Dealer Street Address : _____
City : _____ State/Province : _____ Zip : _____
Country : _____
Dealer Phone : _____

Would you like information sent to you about new products that would benefit your company? Yes No

Recommended Spare Parts

Below is a list of the most common wear/replacement parts for the MiniStitcher. This guide should help you when ordering replacement parts. If the part you need is not listed below, please refer to the more detailed parts list on pages 43-44 in this manual.

Description	Item Number
Bender Bar Latch	9014
Driver	9009-25
Driver Bar	9012A
Grip	9015
Grip Retaining Clip	9023
Grip Retaining Screw	9024
Grip Spring	9019
Grip Spring Retaining Screw	9020
Motor Brush Assembly	PG10289
Solid Clincher	MG10178
Supporter - 1/2"	9026A
Swivel	9038M
Swivel Operating Spring	9046A
Wire Cutter	9048

**PLACE
STAMP
HERE**

**DELUXE STITCHER
COMPANY, INC.**
6635 West Irving Park Road
Chicago, Illinois 60634-2410 U.S.A.
Attn: Customer Service

LIMITED WARRANTY

DeLuxe Stitcher Company, Inc. warrants to the original retail purchaser that this product is free from defects in material and workmanship and agrees to repair or replace, at DeLuxe Stitcher's option, any defective product within 90 days from the date of purchase. This warranty is not transferable. It covers damage resulting only from defects in material or workmanship and does not cover conditions or malfunctions resulting from normal wear, neglect, abuse or accident.

This warranty is in lieu of all other express warranties. Any warranty of merchantability or fitness for a particular purpose is limited to the duration of this warranty. DeLuxe Stitcher shall not be liable for any incidental or consequential damages.

Some states do not allow limitations on how long an implied warranty lasts, or the exclusion or limitation of incidental or consequential damages, so the above limitations or exclusions may not apply to you. This warranty gives you specific legal rights and you may also have other rights which vary from state to state.

To obtain warranty service you must return the product, at your expense, together with proof of purchase to an authorized DeLuxe Stitcher Company Graphic Arts Dealer.

Always use genuine DeLuxe Stitcher parts. When ordering parts, please identify the part number, the part name, the wire size and crown size of your Stitcher.

DeLuxe Stitcher Company, Inc.
Chicago, Illinois 60634-2410
Phone: 773-777-6500 800-634-0810
Fax: 773-777-0156 800-417-9251
E-mail: info@deluxestitcher.com
Web Site: <http://www.deluxestitcher.com>



Declaration of Conformity

We, *DeLuxe Stitcher Company*

6635 West Irving Park Road
Chicago, Illinois 60634-2410 U.S.A
Telephone 773-777-6500
Facsimile 773-777-0156

hereby declare under our sole responsibility that the

IMS-CE *Stitching / Stapling Machines*

to which this declaration relates is in conformity with the
following European product safety directives:

Machinery Safety Directive

(89/392/EEC and amendments
91/368/EEC, 93/44/EEC, 93/68/EEC)

Electromagnetic Compatibility Directive

(89/336/EEC and amendments
91/C162/08, 92/31/EEC, 93/68/EEC)

as is verified by compliance with the following standards:

EN 60204-1:1992	prEN 894-1:1992	prEN 953:1992
EN 294:1992	prEN 894-3:1992	EN 55014:1193
prEN 614-1:1991	prEN 1050:1993	EN 55104:1995

Executed for *DeLuxe Stitcher Company*

this first day of March in the year 1999

By Frank P. Cangelosi Signature Frank P. Cangelosi

Title President



 **DeLuxe STITCHER**
COMPANY INC.
ISP **Stitching & Bindery Products**

6635 West Irving Park Road, Chicago, Illinois 60634-2410
Phone: 773-777-6500 800-634-0810
Fax: 773-777-0156 800-417-9251
E-mail: info@deluxestitcher.com
<http://www.deluxestitcher.com>