



COMPANY INC.

solving your wire stitching needs for over 125 years...

# ISP Stitching & Bindery Products

Machine Model : \_\_\_\_\_ Serial Number : \_\_\_\_\_

Head Serial Number : \_\_\_\_\_

Date Purchased/Installed : \_\_\_\_\_

## ***StitchMaster HP***

### **OPERATION AND MAINTENANCE MANUAL**

SMHP-A25.....StitchMaster....115 V....25 Wire

SMHP-A2125.....StitchMaster....115 V....21x25 Wire

**FOR SERIAL NUMBERS 16000SM AND GREATER...**

**FEATURING THE CAAA2005T3  
STITCHING HEAD**

Before using this Stitcher, all operators must study this manual and follow the safety warnings and instructions. Keep these instructions with the Stitcher for future reference. If you have any questions, contact your local DeLuxe Stitcher Representative or Distributor.



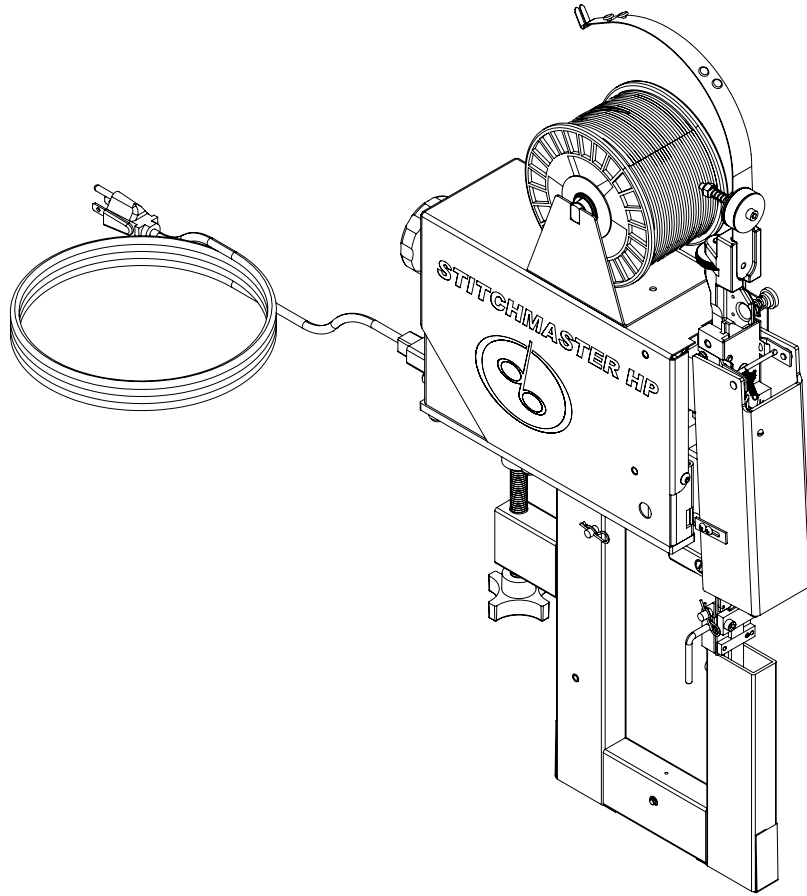

**THANK YOU FOR CHOOSING THE STICHMASTER HP  
FOR YOUR BINDING NEEDS**

***WARNING!***

## ***StitchMaster HP***

Machine operators and others in the work area should always wear safety glasses to prevent serious eye injury from fasteners and flying debris when loading, operating, or unloading this machine.

Do not operate this stitcher without all guards in place. The stitcher will not operate without the front guard closed properly. Do not modify the guards in any way. Always disconnect the power supply before removing any guards for servicing.

Never operate the machine with wire feeding through the head unless there is stock above the clinchers, otherwise serious damage may result.

Always turn power off when making adjustments. Always disconnect the power cord before any disassembly work.

## **Table of Contents**

Introduction .....	6
Specifications .....	7
Installation .....	8
Pre-Inspection .....	8
Inspection .....	8
Mounting .....	8
Assembly .....	9
Wire Threading and Adjusting Wire Straightness .....	11
Maintenance .....	12
Lubrication .....	12
Ordering Spare Parts.....	13
Replacing Spare Parts.....	13
Operation .....	14
Changing Work Thickness .....	14
Adjustments and Settings .....	15
Equalizing Both Legs of Stitch .....	15
Adjusting Clincher Points .....	16
Stitching Process .....	17
Saddle vs. Flat Stitching .....	17
Stops.....	18
Trip Modes .....	19
Troubleshooting .....	20
Stitching Head Parts and Their Function.....	24-32
Dismantling the Stitching Head .....	33
Modifications .....	36
Clincher Arm Adjustment .....	36
Timing .....	37
Appendices .....	38
Exploded Drawings.....	38
Part Number/Description Cross Reference .....	39-49
Wiring Schematic.....	50
Optional Equipment .....	51-53
Notes Section .....	54-55
Warranty .....	56
Registration Card .....	57
Wear/Replacement Parts .....	58

## **Introduction**

The DeLuxe Stitcher **StitchMaster HP** is the Graphic Arts Industry's premier, portable, high-quality stitcher. It is quiet, fast and very dependable, in addition to being affordable. The StitchMaster HP is constructed in such a way that two machines may be mounted side-by-side to effectively create a dual-head stitcher at a cost considerably less than that of traditional multi-head stitchers.

The SMHP-A25 operates on 115VAC and comes standard with parts for 25 gauge or smaller round wire. However, any StitchMaster HP can be modified to accommodate the following wire sizes: 23 or 24 gauge round or 21 x 25 flat.

The StitchMaster HP has a capacity from two sheets up to 1/4" (6.4mm), or sixty sheets of 20 pound bond paper. It accommodates both Flat and Saddle stitching. The StitchMaster HP has side stops which are easily adjusted from 2.5" to 26" wide. There are also pop-up pins for convenient corner stitching. In addition, the StitchMaster HP has movable clinchers for a tight stitch and one knob adjustment for both work thickness and centering the stitch.

The Stitchmaster HP has a rear contact trip and a foot switch for easy operation and single or continuous stitch modes can be accomplished at the touch of a button! It can clamp either to your own work table or to a heavy duty floor stand, which adjusts vertically from 28" to 42". The stand is an optional piece of equipment which can be purchased through your DeLuxe Stitcher Graphic Arts Representative.

The StitchMaster HP can be plugged into any standard wall outlet.

The StitchMaster HP has a 5" (12.7 cm) throat depth for flat or horizontal stitching and a depth of 9" (22.9 cm) for saddle stitching. The heavy-duty work table is 16" (40.6 cm) wide and adjusts easily for flat or saddle work. The overall height combined is 24" (61.0 cm), the depth is 15" (38.1 cm) and the width is 16" (40.6 cm) with the table and 4" (10.2 cm) without the table.

The machine itself weighs 28 lbs. (12.7 kgs.). The shipping weight including the wire spool, foot switch and tables is 55 lbs. (22.7 kgs.).

# **Specifications**

## **Weight**

Shipping Weight	55 lbs (25 kg)
StitchMaster HP Machine Unit	
SMHP-A25	28 lbs. (13 kgs)
Wire Spool	5 lbs. (2.3 kgs)
Foot Switch	4.5 lbs. (2.0 kgs)
Tables	4.7 lbs. (2.1 kgs)

## **Physical Dimensions**

Height	24" (61.0 cm)
Width	
With Tables	16" (40.6 cm)
Without Tables	4" (10.2 cm)
Depth	15" (38.1 cm)

**Stitching Capacity** ..... Two Sheets to 1/4" (6.4 mm)

**Wire Types** ..... 23 through 28 round or 21 x 25 flat  
( 25 gauge round standard )

## **Throat Depths**

Flat (Horizontal)	5" (12.7 cm)
Saddle (Diagonal)	9" (22.9 cm)

**Side Stops** ..... 2" - 14" (5.1 - 35.6 cm)

## **Power Requirements**

SMHP-A25 ..... 115VAC 50/60 Hz

### **Minimum Recommended Circuit Capacity**

SMHP-A25 ..... 1.0 A

### **Unit/Part Number/Stitching Head**

SMHP-A25	2001ASMHD251/2	CAAA2005T3
SMHP-A2125	2001ASMHD21251/2	CAAA2004T6

## **Installation**

### **Pre-Inspection**

Carefully inspect the condition of the shipping container before unpacking your StitchMaster HP. If the container is broken or damaged and there is evidence that the machine may be damaged, immediately notify the carrier who delivered the stitcher and the DeLuxe Stitcher Graphic Arts Representative from whom the machine was purchased.

### **Inspection**

As you carefully unpack the machine, check to make sure all components were delivered and are in good working order. Use **Figure 2** in this manual for reference to the following pieces:

- StitchMaster HP complete with Stitching Head and manual
- Foot Switch with Guard and Cord (PG10230D)
- Wire Spool (25G5 or 2125G5 - optional) on a Spool Shaft (MG10110)
- Spool Cradle (MG10113)
- Trip Switch Assembly (MG10106BA)
- Wire Guide Spring (MG10009A)
- Front Table (MG10083A) with Side Stop Rod Guides (MG10081 and MG10082) and Self Lock Pins (PG10242)
- Rear Table (MG10091A)
- 1/8" Hex Key Wrench (PG10293)
- Stitch samples

Note: Check the nameplate on the back of the stitcher to verify the operating voltage meets your requirements.

### **Mounting (Figure 1)**

You may mount the StitchMaster HP by clamping it to a secure work-table or to a StitchMaster HP Floor Stand (an optional purchase) as shown. Make sure that the table you choose is sturdy and heavy enough to support the weight of the StitchMaster HP. Tables which are not suitable will have a tendency to tip forward onto the operator. Place the machine where the operator will have sufficient light and working space. Make sure the Clincher Arm Knob (P3793) is turned tightly to secure the Machine to the work surface.

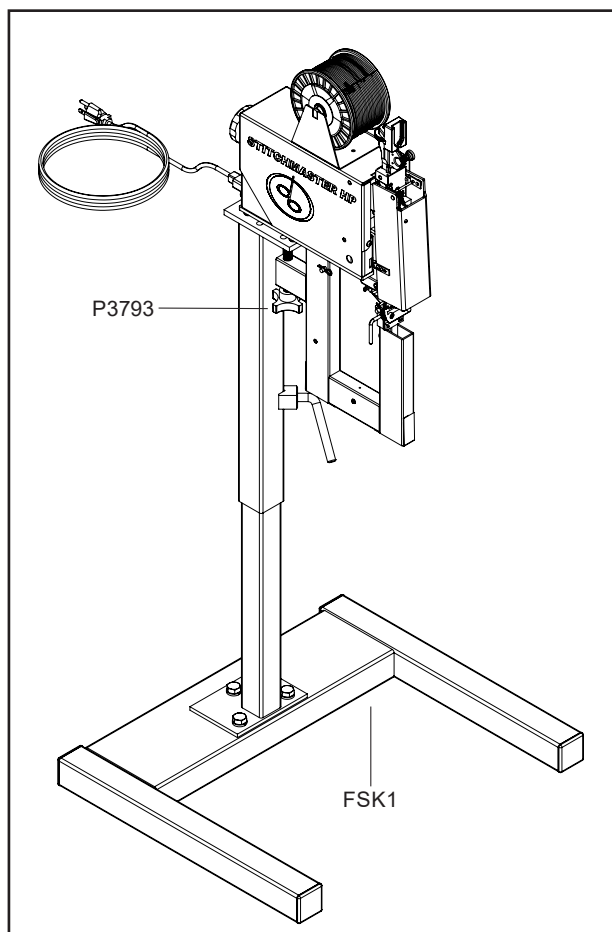

**Figure 1**



## Assembly (Figure 2)

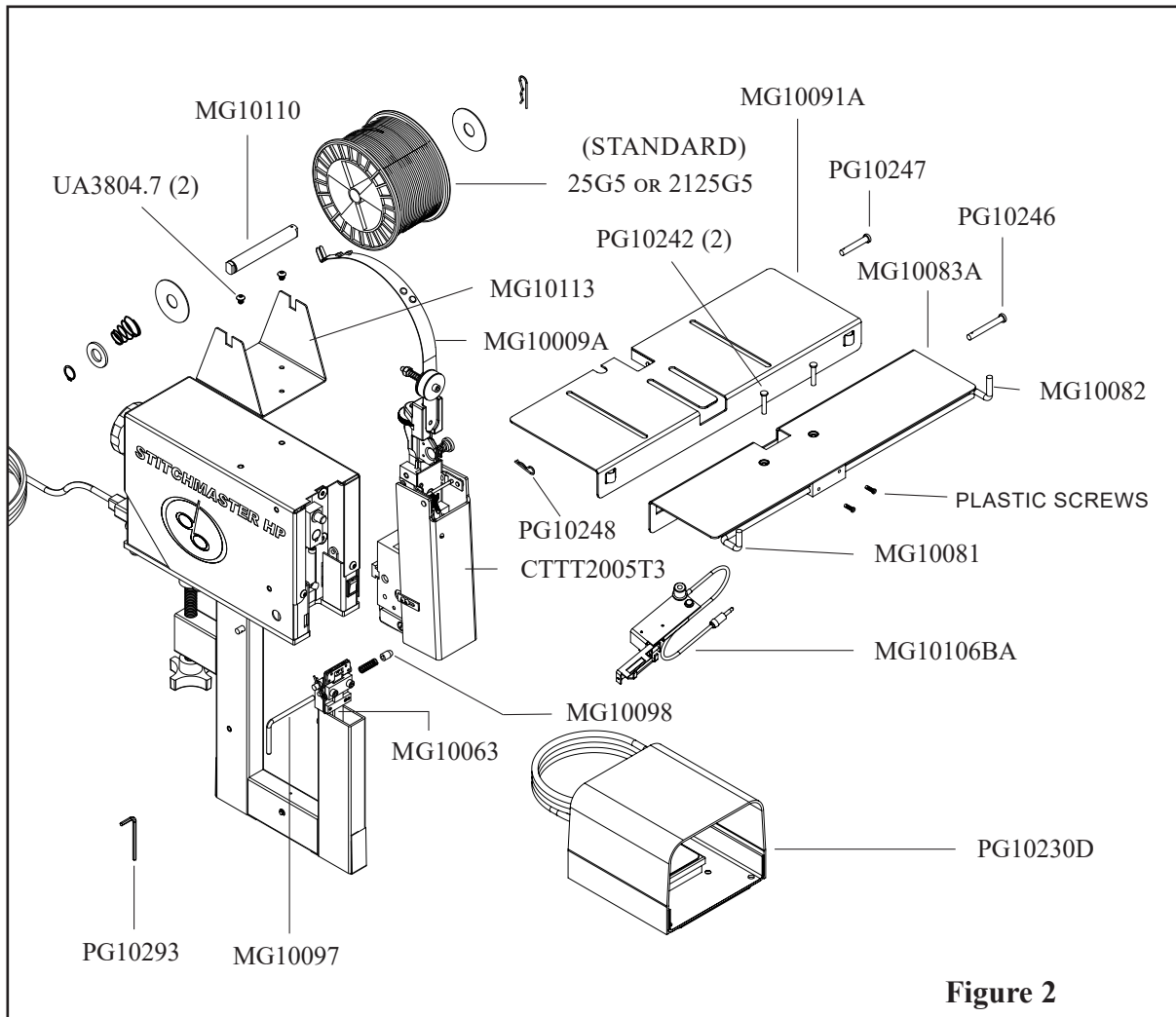

Figure 2

### CAUTION

Always disconnect the power cord before assembling the StitchMaster HP or making any adjustments.

Assemble the components of the StitchMaster HP as needed. Use **Figure 2** for part number reference. The Wire Spool Cradle (MG10113) mounts with the two (2) screws (UA3804.7) on the top of the cover (MG10044B). Use the supplied 1/8" Hex Key Wrench (PG10293) to remove the screws and then secure the Cradle to the Cover. The Wire Spool (25G5 or 2125G5) comes assembled on the Spool Shaft (MG10110) which slips into the slots in the cradle. Pay attention to the payoff direction of the wire, see **Figure 2**, so that it matches the above drawing.

The Wire Guide Spring (MG10009A) slides into the slot in the Wire Guide Spring Bracket (MG10001A) on the top of the Head located at the front of the machine.

The Foot Switch (PG10230D) plugs into the Foot Switch Receptacle (PG10629) which is located in the rear of the machine.

The Rear Work Table (MG10091A) mounts to the rear of the Clincher Arm (MG10052A) using a Rear Table Pivot Pin (PG10247) and a Table Pivot Pin Clip (PG10248). Pay attention to the direction of the Pivot Pin Clip to avoid hitting the Trip Switch Assembly (MG10106BA). Assemble the Front Table (MG10083A) to the Clincher Plate Mounting Block (MG10063) after pulling the Adjustment Handle (MG10097) to the left and out of the way. The Adjustment Nut (MG10098) should spring into one of the two holes in the bottom of the right pivot plate on the Front Table. The hole chosen determines whether the StitchMaster HP will be set up for Flat or Saddle Stitching. Slide a Clevis Pin (PG10247) into the hole in the top of the Front Table, through the Clincher Plate Mounting Block (MG10063) and out the other side. Secure the Clevis Pin with a Table Pivot Pin Clip (PG10248) to keep it in position.

The Trip Switch Assembly (MG10106BA) mounts in the slots on the Rear Work Table (MG10091A) after removing the Lock Nut (MG10105) and the Lock Nut Washer (P2126). Refer to **Figure 3** for the Trip Switch mounting. If positioned correctly, the Trip Switch Assembly should use the mounting or right slot on the back of the table and the fingers of the Trip Lever (MG10100) should be visible through the two center slots. Once the Trip Switch Assembly is in place, replace the washer and the lock nut. After the assembly is completed, the entire assembly should slide freely front to back when the lock nut is loosened and remain in place when it is tightened.

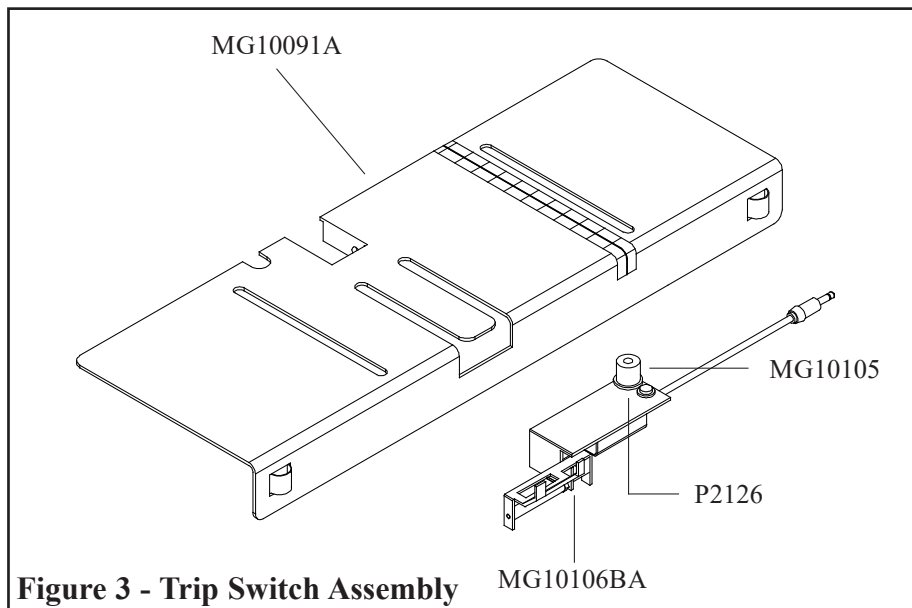

**Figure 3 - Trip Switch Assembly**

Plug the Trip Switch Plug Assembly (MG10106BA) into the Table Trip Jack (CG190B, see p. 38) on the **underside** of the machine on the left.

Once the assembly is complete, turn the machine over by hand a few times using the Shaft Extension Handle (PG10211) located at the rear of the unit. All parts must operate freely before turning on the power. Push and turn the handle counter-clockwise (looking from the rear of the machine)

to manually rotate the machine. You are ready to plug in your StitchMaster HP, but **do not** turn on the main power yet.

**⚠ WARNING**

Make sure the Swivel has been removed before tripping the StitchMaster HP to avoid jams and the chipping of parts.

### **Wire Threading and Adjusting Wire Straighteners (Figure 4)**

1. Draw wire (Index A) by hand, from the coil.
2. Thread the wire through the slot (Index B) at the end of the wire guide spring, through the wire guides (Index C), between the thin and thick felt wire wipes (Index D), through the wire guide spring bracket assembly (Index E), and through the lower wire straightener (Index F).
3. Release the rotator operating spring (Index H) from the rotator and swing it to the left. Remove Rotator (Index K).
4. Thread the wire between the tension pawl and tension roll (Index G). Feed the wire through the wire cutter lead-in hole (Index I) in the bottom of the face plate.
5. Push grip post to left to open the grip (Index J). Insert wire and release the post so that the grip engages the wire for feeding into the rotator.
6. To check adjustment, hold open grip (Index J) and pull about 1 1/2 feet of wire from below face plate. Cycle machine once by hand to cut wire. Cycle machine again by hand to observe wire straightness. The wire (Index L) should point straight down, prior to being cut.
7. Adjust the upper wire straightener, beginning at position shown, (Index E) so that the wire points straight down. Adjust the lower wire straightener, beginning at the 3:00 o'clock position, (Index F) so that the wire (Index L) feeds straight down.
8. Replace the rotator and rotator operating spring.

### **NOTE:**

**When changing coils or wire sizes, check straighteners to insure proper wire feed.**

**Do Not Operate Stitcher  
Without reading Operating  
Instructions.  
Do Not Operate Without Work  
under Stitching Head.  
Do Not Operate Without Guards.**

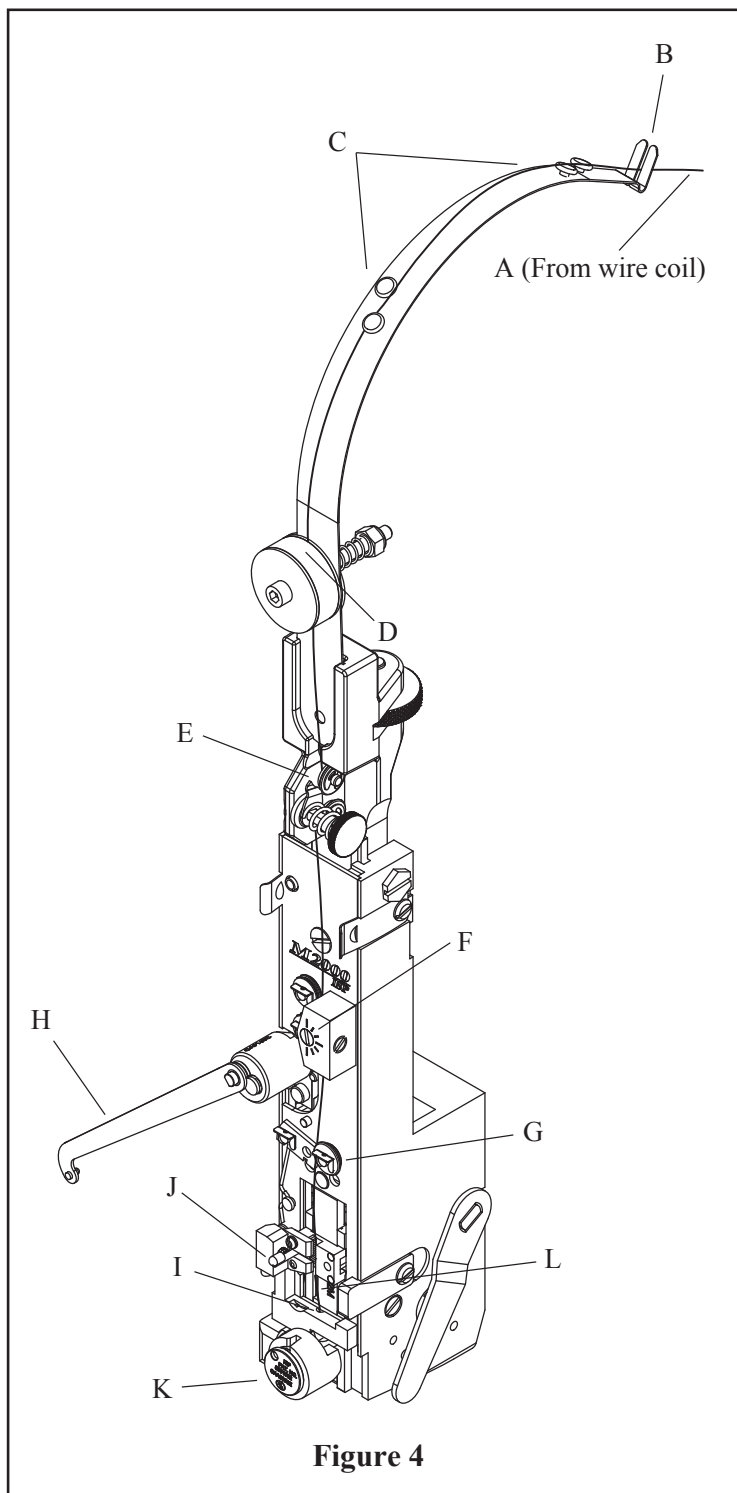

**Figure 4**

## Maintenance

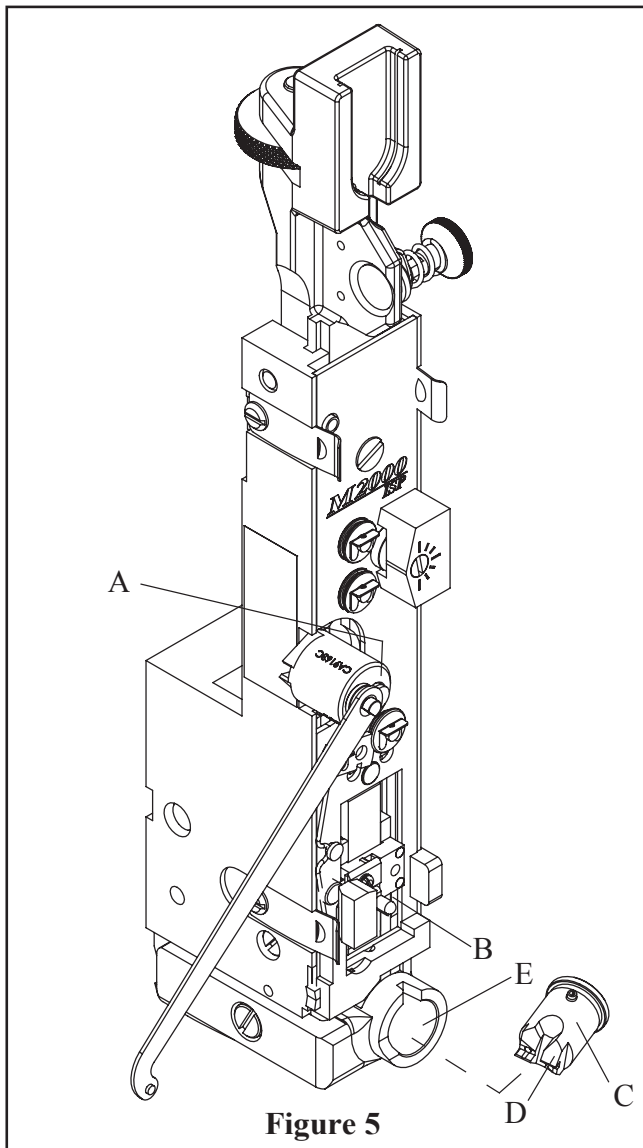

Typically, the 1/2 inch crown stitcher will run for 1,000,000 cycles without additional lubrication. However, the following procedure used after each spool of wire will assure optimum life and performance. Use **ISP** lubricant #CA9641.

- A. Inject lube into hole, or remove and lube shafts.
- B. Wipe area clean and inject a small amount of lube into cam area.
- C. Remove rotator, wipe rotator clean and lube rotator body.
- D. Apply lube to rotator ramp.
- E. Wipe clean inside of rotator holder.
- F. Inject a small amount of lube into cam area of driver bar.

## Lubrication (Figures 5 & 6)

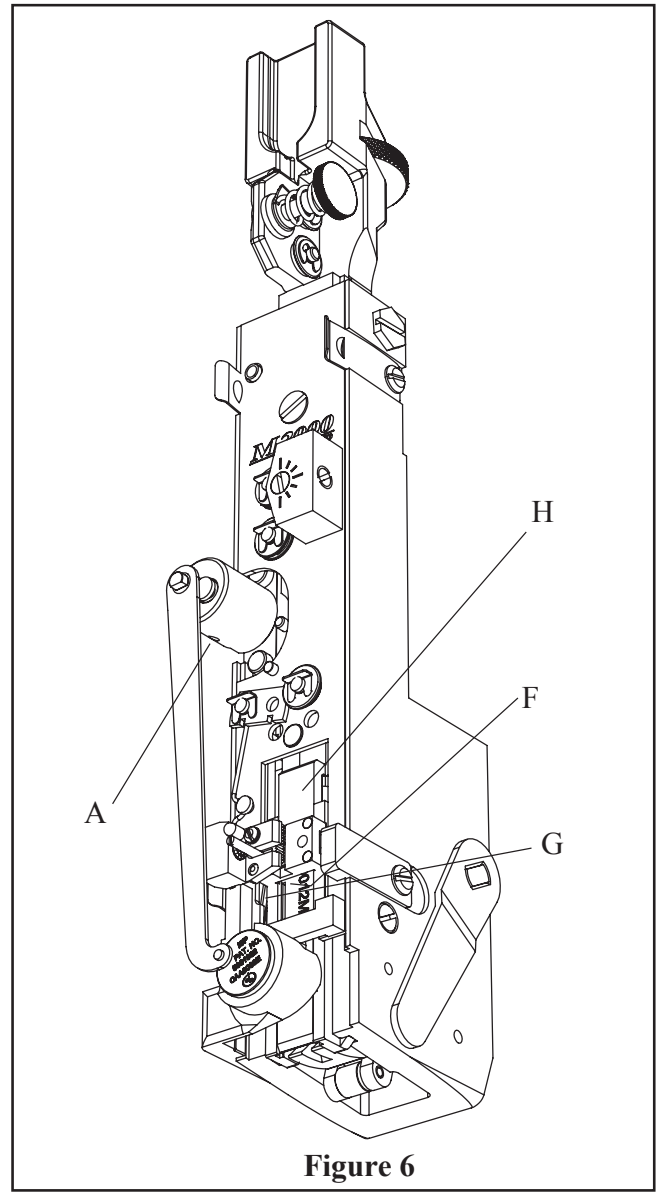

- G. Inject lube into cutter operating slide.
- H. Wipe driver clean, and apply a light coating of **ISP** lubricant.

After prolonged use (or storage) accumulations of wire dust, dirt, or other contaminants can mix with the stitcher lubricant. This will reduce the lubricant's effectiveness. The following procedure is recommended every 1,000,000 cycles.

1. Disassemble the head and clean all parts.
2. Lightly lube all sliding surfaces using lubricant #CA9641.
3. Double check lube points A through H.

## Ordering Spare Parts

In time, you will need to replace some parts in your StitchMaster HP. When this happens, first locate the needed part in one of the following diagrams. Then locate the DeLuxe Stitcher part number and contact your Graphic Arts Representative to order the part by the part number, description and quantity.

**Always disconnect the power cord**  **CAUTION**  
before any maintenance or adjustments are  
made to the StitchMaster HP

## Replacing Spare Parts

The following are some of the more common wear parts which will need to be removed and replaced in your StitchMaster HP. Most replacements require the Stitcher Head to be removed from the StitchMaster HP.

While some adjustments can be made to the StitchMaster HP and the stitcher head, most maintenance and general repairs have to be made with the stitcher head removed from the machine.

Cut the wire from the wire spool just below the Wire Guide Spring Bracket (MG10001A). Pull the remaining wire, from the stitcher head, out from the bottom. Remove the Wire Guide Spring (MG10009A) from the Wire Guide Spring Bracket (MG10001A).

Loosen the Bonnet Clamp Eccentric Handle (CTT9003C) and remove the Stitcher Head from the StitchMaster HP. Place the Head on a clean work area. Be aware that the Driving Shaft Connection Link (2215) is removed from either the Driving Slide Assembly (CAA2623C) or the Crank (MG10031A).

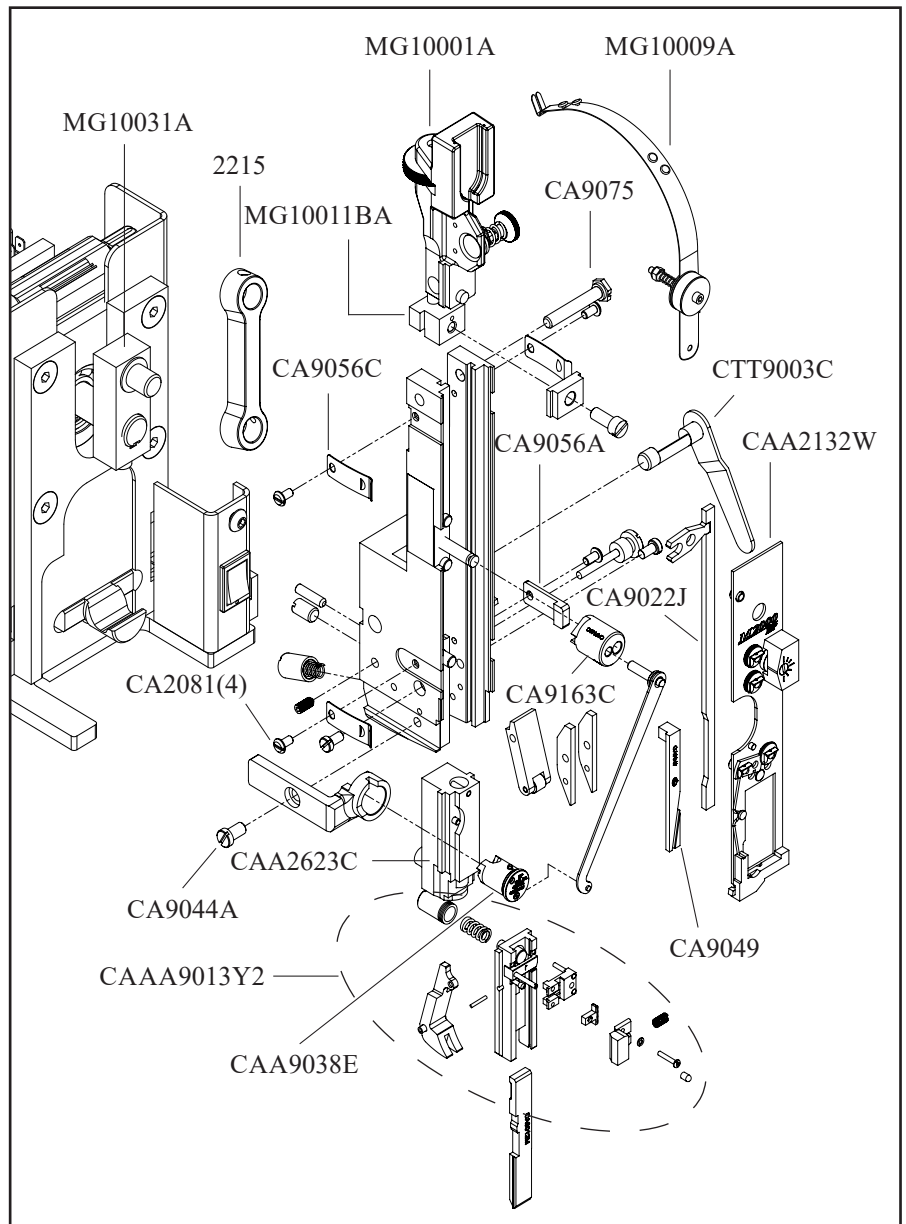

Figure 7 - Replacement Parts

## Operation

### Changing Work Thickness

### Adjusting the Wire Draw (Figure 8)

The overall length of the stitch is controlled by the amount of wire that is drawn from the spool after each stroke of the StitchMaster HP. To change the overall length of the stitch, loosen the Face Plate Adjusting Lock Screw (9799) on the front of the Head. Turn the Face Plate Adjustment Knob (MG10013) clockwise to raise the Face Plate which draws more wire - making the overall length of the stitch longer. If the overall length is too long, turn the Face Plate Adjustment Knob counter-clockwise to lower the Face Plate and decrease the draw of wire pulled from the Wire Spool. Once the correct length of wire has been achieved, tighten the Face Plate Adjusting Lock Screw. As a rough gauge, the distance the Face Plate is above the Bonnet (CT2604) should be equal to the work thickness.

*Note: If the Face Plate is adjusted too high (turning the Face Plate Adjustment Knob too far clockwise) the Grip (CA9015D) will lock in an open position and draw no more wire. At maximum capacity it may not be possible to completely close the gap between the staple legs.*

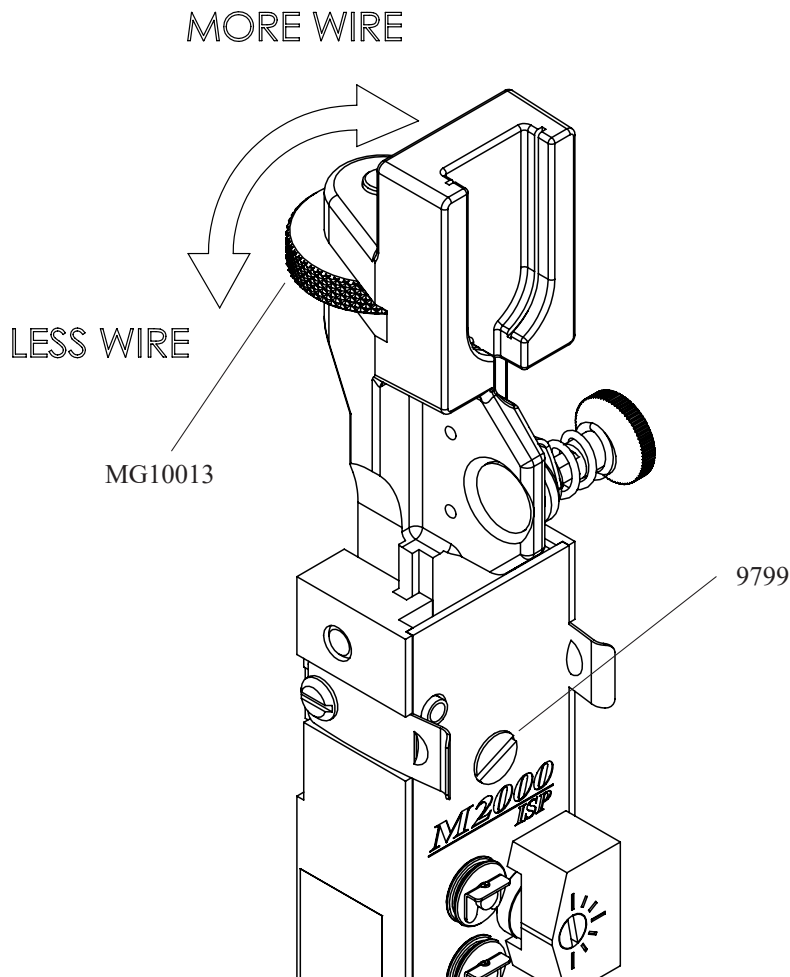

Figure 8

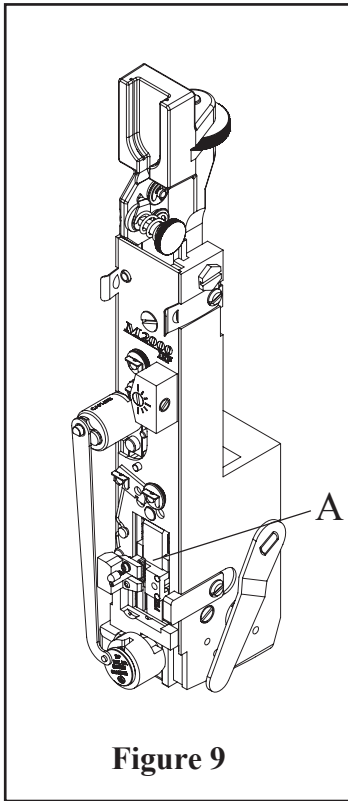

Figure 9

**⚠ CAUTION**

**MAKE ALL ADJUSTMENTS WITH THE POWER OFF AND THE STITCHING HEAD IN NEUTRAL POSITION!** (Fig. 9)

In neutral position, the wire grip assembly (Index A) is stopped at the top of the slot in the face plate.

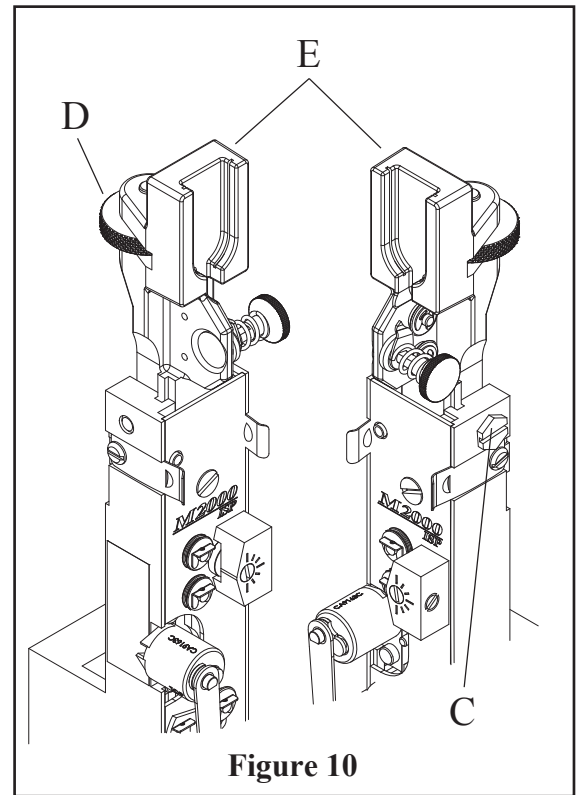

Figure 10

**Stitching Adjustments**

Best stitching performance will be assured if all adjustments are made so that you get the following results:

1. Good Cut-Off
2. Uniform Wire Draw
3. Equal Leg Length
4. Proper Clincher Alignment
5. Sufficient Compression

**Equalizing Both Legs of Stitch (Figure 10)**

1. Loosen the wire guide locking bolt (Index C).
2. Turn adjusting screw (Index D) clockwise to shorten left leg of stitch; counter clockwise to lengthen left leg.
3. Tap bracket (Index E) down before tightening screw (Index C).

## Adjusting the Clincher Points (Figure 11)

*Note: The standard StitchMaster HP accepts only 25-26 wire. If other wire sizes are required contact your local DeLuxe Stitcher Graphic Arts Representative for information.*

If the clinch on the staple is not tight enough, the Clincher Points (CA9083A or 9083C) have to be raised. The Clincher Rod (MG10070) controls the height of the Clincher Points. First remove the Cover (MG10044B) from the Frame (MG10020BA). Release the Clincher Rod from the Cam Lever (MG10067) by pressing down on the bend of the Clincher Rod. Turn the Clincher Rod Stud (MG10072) clockwise to lower the Clincher Slide (MG10062), which lowers the Clincher Points. Engage the Clincher Rod with the Cam Lever again to test the clinch. If the Clincher Points are too low, adjust the Clincher Rod Stud counter-clockwise to raise the Clincher slide, which in turn raises the Clincher Points. Be sure to always re-insert the Clincher Rod and Clincher Rod Stud into the Cam Lever before testing the height of the Clincher Points.

The final position of the Clincher Points should be flush (or slightly above flush) with the Clincher Plate (9800A). The best way to see the position of the Clincher Points is to manually turn the StitchMaster HP over. When the Driver (CA9012M) is at the lowest position of its stroke, the Clincher Points are at their highest position. Turn the Crank (MG10031A) just past this point to reveal the Clincher Points' position. To be sure that the Points are at the best position possible, test the StitchMaster HP after turning the Clincher Rod Stud 1/2 turn each way. Replace the Cover.

*Note: This adjustment is very sensitive - one half turn should affect the clinching considerably.*

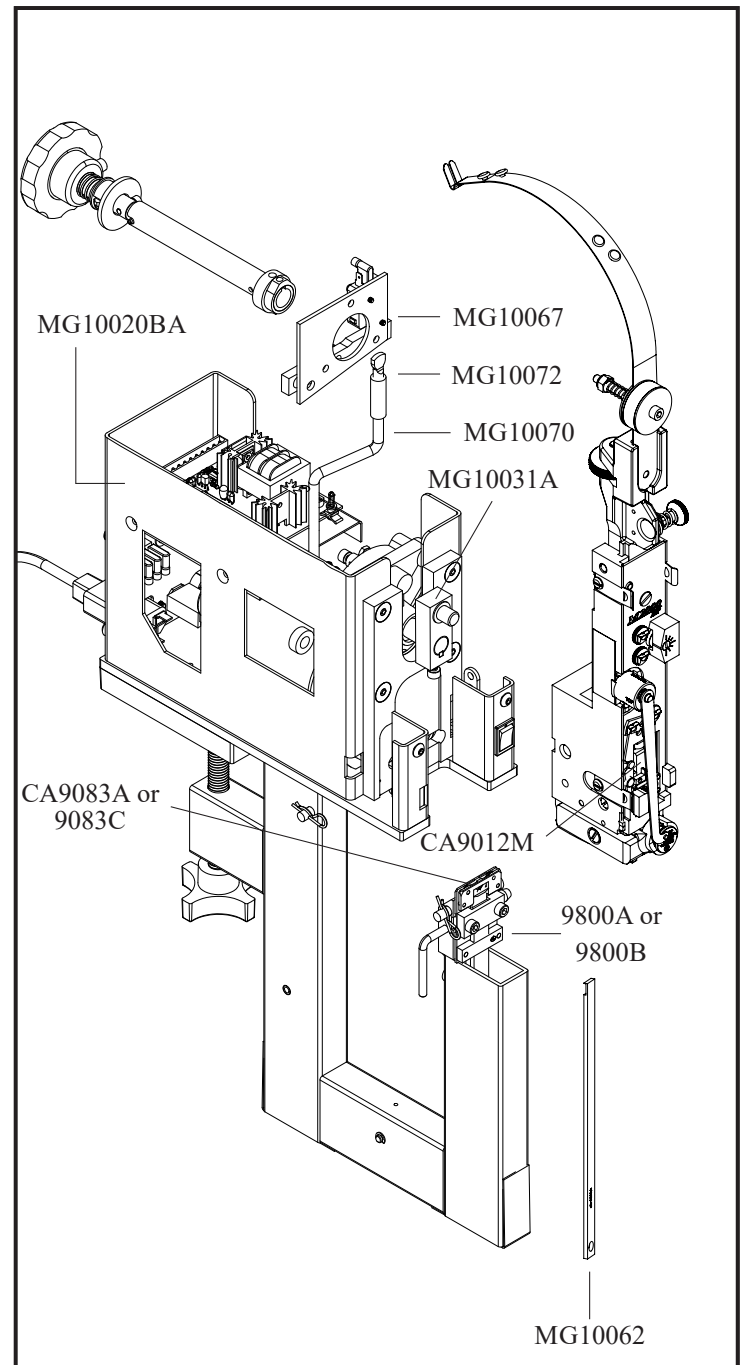

**Figure 11**

**CAUTION**

**Do not operate the StitchMaster HP Stitcher until all guards are in place**



## Stitching Process

The StitchMaster HP has been designed to accommodate a variety of jobs. For this reason, adjustable work tables and work stops have been installed on the StitchMaster HP. The following is a brief explanation of the options available on the machine.

### Saddle Stitching (Figure 12)

Push the Springs back into the holes in the underside of the Front Table (MG10083A) with your thumbs, allowing the Rear Work Table (MG10091A) to drop out of the way. Be sure that the Trip Switch Assembly (MG10106BA) is adjusted just inside the Rear Work Table so that it does not hit the Front Work Table or the Clincher Arm (MG10052A) as the Rear Work Table is lowered. After the Rear Work Table is out of the way, pull the Table Adjustment Handle (MG10097) to the left and drop the Front Work Table into the saddle position.

### Flat Stitching (Figure 12)

Pull the Table Adjustment Handle to the left and lift the Front Work Table to the flat position. Pull the Rear Work Table up until the spring pops into the holes in the back of the Front Work Table.

*Note: You may have to push the springs, slightly to clear the Front Table. (see Figure 12)*

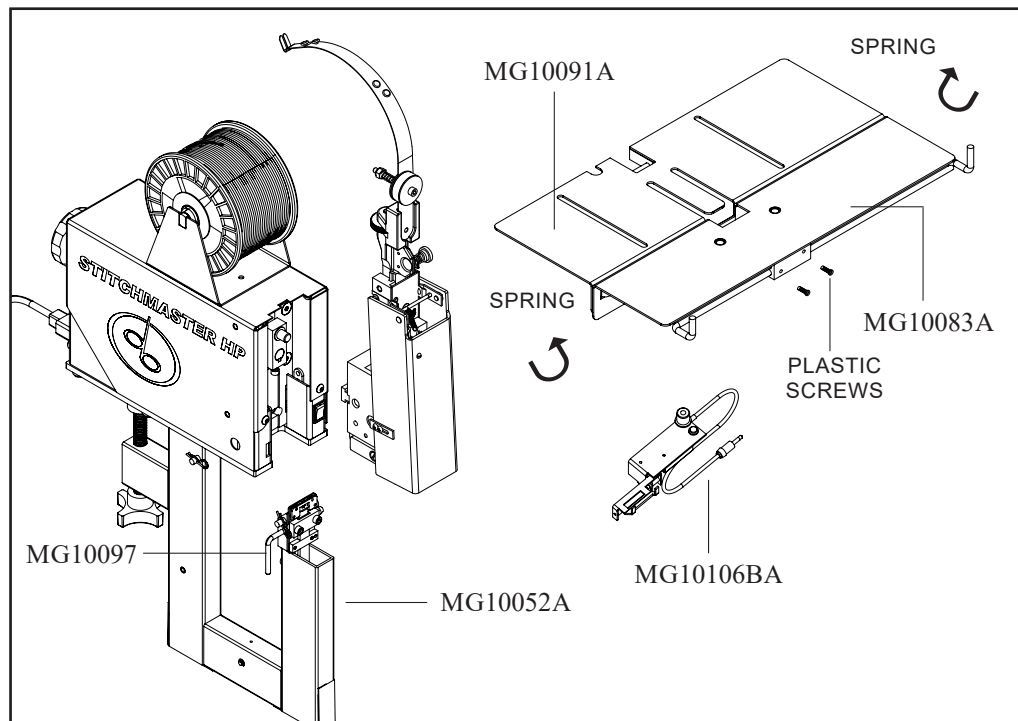

Figure 12 - Saddle and Flat Stitching

## **Side Stops (Figure 13)**

Loosen the Stop Rod Screws (PG10243) on the front of the Front Work Table (MG10083A) and slide the Left and Right Side Stops (MG10081 and MG10082) out to the necessary distance from the Stitcher Head to position the work under the StitchMaster where you will stitch.

## **Corner Stitch Stops (Figure 13)**

Corner Stitch Stops are applicable to flat work only. Push the Corner Stitch Pins (PG10242) up from the bottom of the Front Work Table (MG10083A) until they lock into place. One or both of the Corner Stops may be used to locate the accurate stitch position.

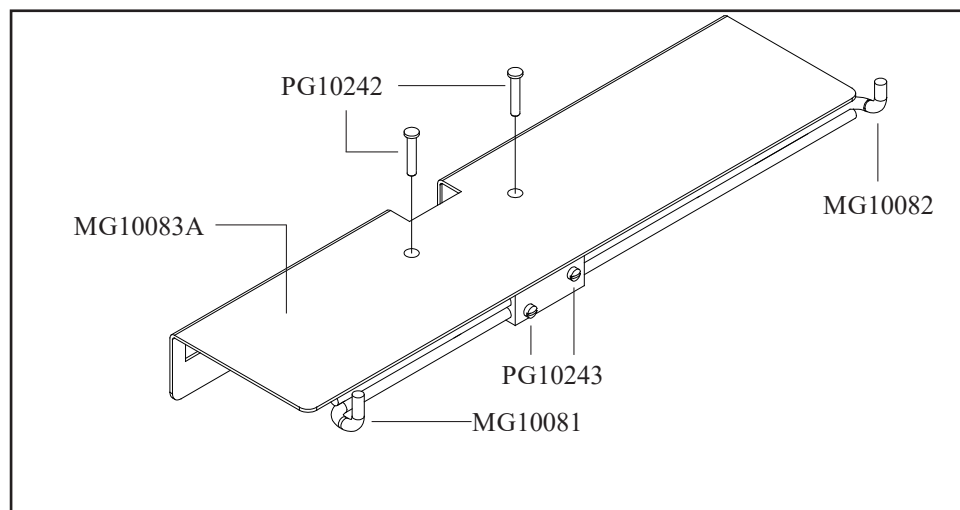

**Figure 13 - Side and Corner Stops**

## **Solid Backstop**

The Solid Backstop is an optional assembly which can be ordered from your DeLuxe Stitcher Graphic Arts Representative - order the SMK2 Backstop Kit. The Backstop is mounted on the Rear Table of your StitchMaster and locates the depth of the stitch.

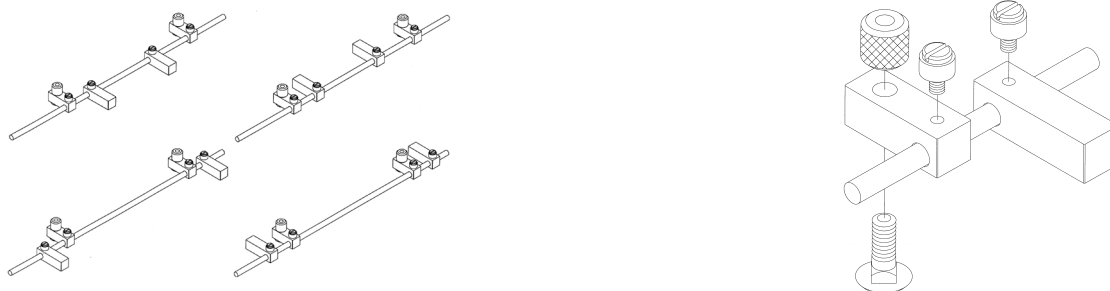

**Figure 14 - Solid Back Stops**

### **Trip Switch (Figure 15)**

The Trip Switch Assembly only works for flat stitching. Loosen the Lock Nut (MG10105) and slide the Trip Switch Assembly (MG10106BA), front or back to the desired position on the Rear Work Table (MG10091A). Use the Backstop Gauge Sticker (PG10214) on the Rear Work Table as a guide. When the correct locating position has been determined, tighten the lock nut.

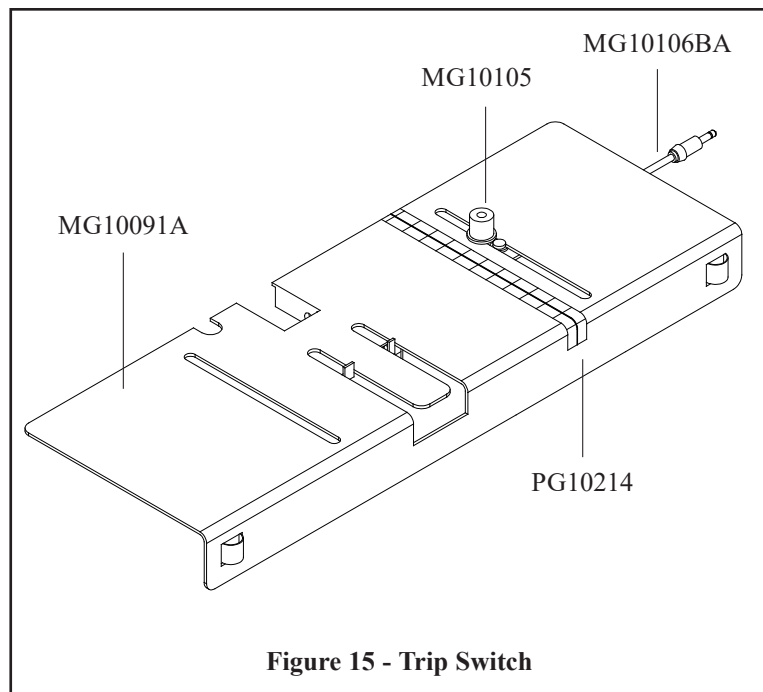

**Figure 15 - Trip Switch**

### **Stitch Mode**

The Stitch Mode Switch (PG10232) is found on the back of the StitchMaster HP. (The switch on the left, looking from the rear of the machine.) There are two modes; single or continuous stitching. Single stitching is used for production. In the single trip mode only one stitch will be released at a time, no matter how long the trip switches are activated, whereas the continuous stitch mode the machine will continue to deliver stitches as long as one of the trip switches is activated. The continuous stitch mode is used only for testing and trouble-shooting.

### **Trip Mode**

The Trip Mode Switch (PG10232) is also found on the back of the StitchMaster HP. (The switch on the right, looking from the rear of the machine.) Either the foot trip or the table trip mode can be selected. The table trip mode or Trip Switch Assembly (MG10106BA) can be used only for flat work. The Trip Switch Assembly plugs into the underside of the StitchMaster, on the left. For all saddle stitch work the foot trip mode must be used. Be sure that the Foot Switch (PG10230D) is plugged into the rear of the StitchMaster HP and the Trip Mode Switch is toggled for this mode.

## **Trouble Shooting** (Figure 16)



**Do not operate the StitchMaster HP Stitcher  
until all guards are in place**

The following is a brief list of problems and solutions which should cover the majority of situations encountered when stitching with the StitchMaster HP. Most problems with stitches are due to incorrect adjustments on the machine or to the normal wear of parts.

**PROBLEM:** The machine does not cycle and the Main Power Switch (PG1022B) is on.

**SOLUTION:** Make sure the Power Cord (PG10410) is properly plugged into a live receptacle. Check to see if the Circuit Breaker CK163 has been tripped. If so, push it to reset. If it still does not cycle, make sure the Foot Switch (PG10230D) or Trip Switch Assembly (MG10106BA) is plugged in and the corresponding Trip Switch position is selected. The Head Guard (PG10003) must be in place to fully depress the safety interlock, otherwise the StitchMaster will not function.

*Note: if the Head Guard moves enough to lose contact with the Safety Switch (PG10229) the Head Guard must be rotated upward to clear the Safety Switch and re-closed.*



## HERE'S HOW A PERFECT STITCH LOOKS

Should stitches appear in any form other than illustrated, one or more kinds of mechanical trouble may have caused the malformation. The possible causes and remedies are given for each kind of mechanical trouble and are listed under each section. The remedies are indexed to the Adjustments Section which gives more detailed information about your stitcher, the mechanical trouble that may occur and suggested remedies. Unless you recognize the correct cause, check each possible cause given.



<b>TROUBLE</b>	<b>POSSIBLE CAUSE</b>	<b>REMEDY</b>
<b>A. Defective Stitches</b>		
<p>1. One or both legs buckled.</p>  <p>NOTE: Since buckled legs are often concealed in the work and may appear the same as a short leg, always remove two or more stitches to see which is occurring.</p>  <p>2. Wrinkled crown.</p>	<ol style="list-style-type: none"> <li>1. Clincher is worn or improperly aligned.</li> <li>2. Insufficient compression.</li> <li>3. Unequal leg length</li> <li>4. Burred stitch leg.</li> <li>5. Incorrect wire size.</li> <li>6. Worn bender bar.</li> </ol>	<p>"B,C" Page 24, 25</p> <p>"A" Page 24</p> <p>See "To Equalize Both Legs of Stitch" Page 15</p> <p>"I" Page 29</p> <p>"K" Page 30</p> <p>"D" Page 25</p>
<p>3. Length of one leg varies</p> 	<ol style="list-style-type: none"> <li>1. Leg Lengths not adjusted properly</li> <li>2. Gripper is worn or dirty</li> <li>3. Grip release slide is worn</li> <li>4. Broken wire guide spring</li> <li>5. Excessive tension on wire straightener</li> <li>6. Worn Driver bar</li> <li>7. Worn Tension Pawl or weak tension pawl spring</li> <li>8. Weak or broken grip spring</li> </ol>	<p>See "To Equalize Both Legs of Stitch" Page 15</p> <p>"H" Page 27</p> <p>"H" Page 27</p> <p>Replace</p> <p>"M" Page 31</p> <p>"F" Page 26</p> <p>"O" Page 32</p> <p>"H" Page 27</p>

Figure 16 - Troubleshooting





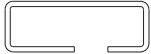

<b>TROUBLE</b>	<b>POSSIBLE CAUSE</b>	<b>REMEDY</b>
4. Corner of crown distorted or fractured 	1. Excessive compression 2. Broken driver end 3. Worn bender bar 4. Clincher improperly aligned or worn 5. Incorrect wire size	"A" Page 24 "G" Page 27 "D" Page 25 "B,C" Page 24, 25 "K" Page 30
5. Stitch crown not flat and legs not bent into work 	1. Insufficient compression	"A" Page 24
6. One or both legs turn out 	1. Clincher improperly aligned 2. Dull cutters	"C" Page 25 "I" Page 29
7. Flat piece of wire 	1. Rotator is dirty 2. Improperly adjusted lower wire straightener 3. Broken or worn rotator 4. Improperly aligned rotator	"L" Page 30 "M" Page 31 "L" Page 30 "L" page 30
8. Stitches come out in pieces 	1. Improperly aligned rotator 2. Weak rotator operating spring 3. Improperly adjusted upper wire straightener 4. Incorrect wire size 5. Wire jammed in bender bar grooves	"L" Page 30 "L" Page 30 "M" Page 31 "K" Page 30 "D" Page 25
9. Both sticher legs are either too long or too short 	Face plate not adjusted properly	See "Changing Work Thickness" Page 14

Figure 16 - Troubleshooting

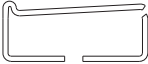
<b>TROUBLE</b>	<b>POSSIBLE CAUSE</b>	<b>REMEDY</b>
----------------	-----------------------	---------------

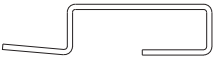
**B. WIRE BUCKLES**

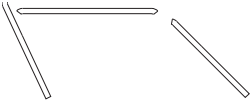
<p>1. Wire buckles above the grip and below the tension pawl</p>  <p>(CTTT2605 Scene 10 VA)</p>	<p>1. Worn driver bar</p> <p>2. Worn bender bar latch</p> <p>3. Worn or broken bender bar friction plug and/or spring</p>	<p>"F" Page 26</p> <p>"G" Page 27</p> <p>"E" Page 26</p>
<p>2. Wire Buckles above the wire cutters and below the grip</p>  <p>(CTTT2605 Scene 10 VB)</p>	<p>1. Improperly aligned rotator</p> <p>2. Worn or broken wire cutters</p> <p>3. Burrs on rotator</p> <p>4. Improperly adjusted lower wire straightener</p> <p>5. Worn or broken wire cutter operating slide</p> <p>6. Wire cutter slot in face plate worn</p>	<p>"L" Page 30</p> <p>"I" Page 29</p> <p>"L" Page 30</p> <p>"M" Page 31</p> <p>"J" Page 30</p> <p>"I" Page 29</p>

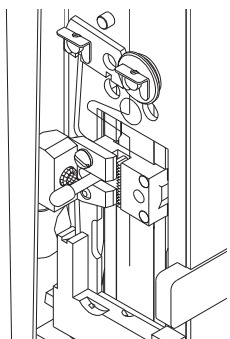
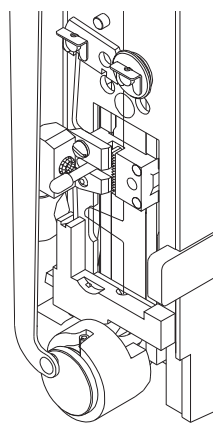
**C. GRIP**

<p>1. Grip does not close</p>	<p>1. Face plate is too high</p>	<p>See "Changing Work Thickness" Page 14.</p>
-------------------------------	----------------------------------	---

Figure 16 - Troubleshooting

**CAUTION!**

Always disconnect the power cord before any maintenance or adjustments are made to the **StitchMaster**

### **A. Insufficient or Excessive Compression**

Proper compression of work between the clincher and the bender bars is necessary so that the stitch penetrates the work material and clinches correctly. To test for compression, drive several stitches into sample work material. With proper compression, stitches hold the work together firmly and the clinched legs do not overlap. In the following instances, either one or all of the conditions may exist: with insufficient compression, stitch legs overlap, crown of the stitch is fractured, and the work mutilated. The method for obtaining proper wire draw and compression is detailed in the Operation Section on Page 13 under the heading, "Changing Work Thickness".

### **B. Clincher (Figure 17)**

The purpose of the clincher is to turn the legs of the stitch back after they have penetrated the work material. There are two types of clinchers:

1. Solid (stationary) Type-makes a loop clinch.
2. Activated (moving) Type-makes a flat clinch.

With the Solid (stationary) Type clincher, the legs of the stitch must strike the clincher at the same time and with equal spacing from the outside edges of the grooves. The grooves in the clincher should be smooth. Any interference (particularly worn or pitted grooves), which change the original radii, will cause the stitch legs to buckle and/or the corners of the crown to fracture.

With the Activated (moving) Type clincher, the stitch legs must enter the clincher at the same time

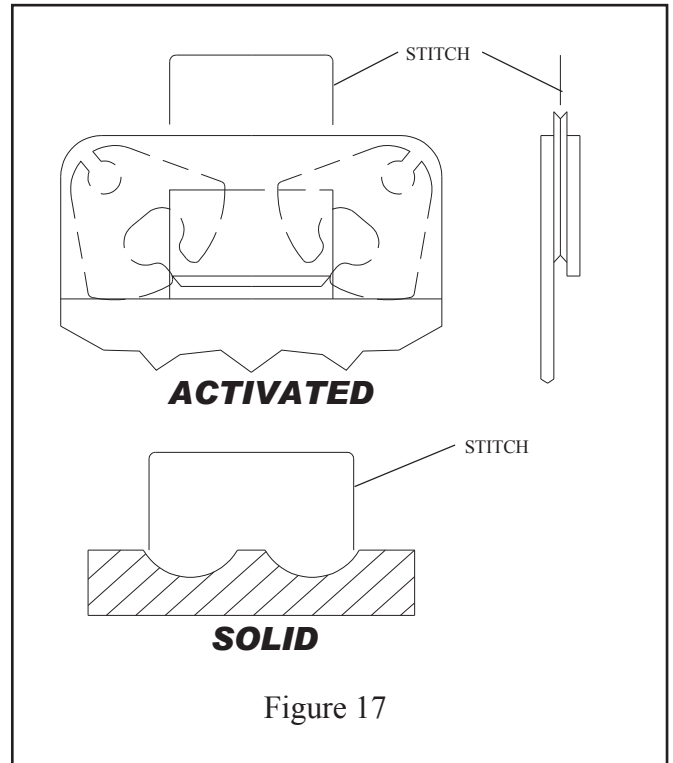

Figure 17

and with equal spacing from each side. When the stitch legs have penetrated the work material, the moving clinchers are raised to bend the legs towards each other and up flat against the work. The clincher points must bend both legs of the stitch against the work with the same force. Clincher points must always move freely and not bind. Dirt, wire chips, etc. will cause the points to bind.

The clincher points are in a retracted position in the clincher box until the stitch legs penetrate the work material. After the legs penetrate, the clincher points move upward to give a neat, flat clinch against the bottom surface of the work material. If the clincher points remain in the up position, the legs of the next stitch cannot penetrate the work material, causing the stitch legs to buckle and/or the corners of the crown to fracture. Examine the clincher points, clincher slide for possible binding. Clean and oil.

If clincher points rise to high, they fracture the stitch legs and/or mar the work. If the points do not rise high enough, the legs will not clinch flat. Adjust the height of the clincher points. For most work the clincher points should rise to be level with the top of the clincher housing.



Inject lube into cutter operating slide.

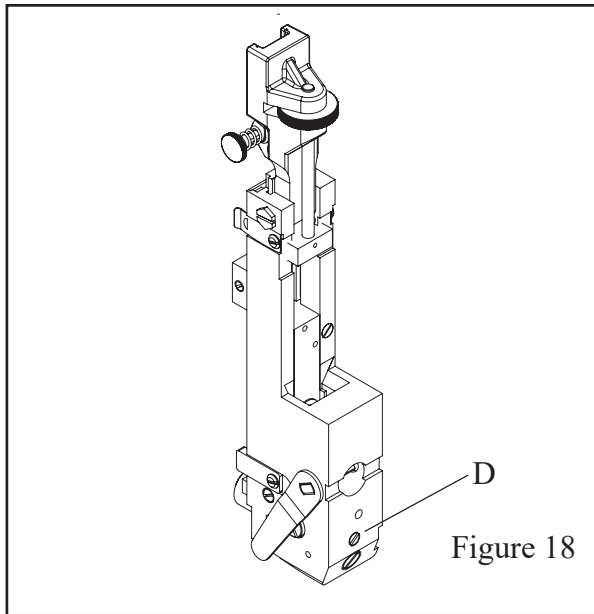

Figure 18

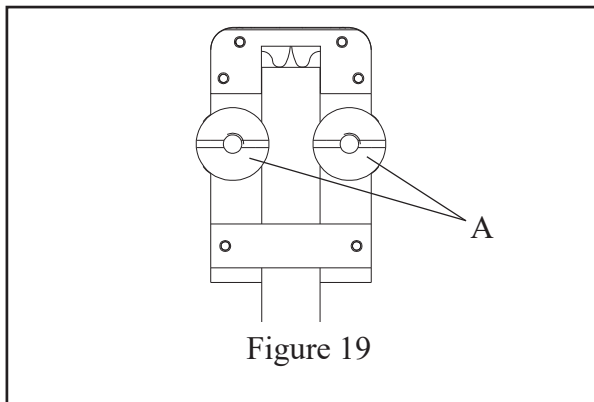

Figure 19

### **C. Head/Clincher Alignment (Figure 18, 19)**

To test alignment: Drive several stitches into a section of material identical to that which is to be stitched. The clinched legs should be identical and aligned with each other. If the legs are not in alignment make one of the following adjustments:

1. To adjust for front-to-rear alignment: (Fig. 18)
  - a. Turn power off. Cycle the stitcher by hand until legs of the stitch appear just below the bender bar to determine if the head should be moved to the front or rear.
  - b. Remove stitcher from machine.
  - c. Turn the head aligning screw (Index D) clockwise to move the head backward; counterclockwise to move the head forward.
  - d. Install stitcher head on machine.

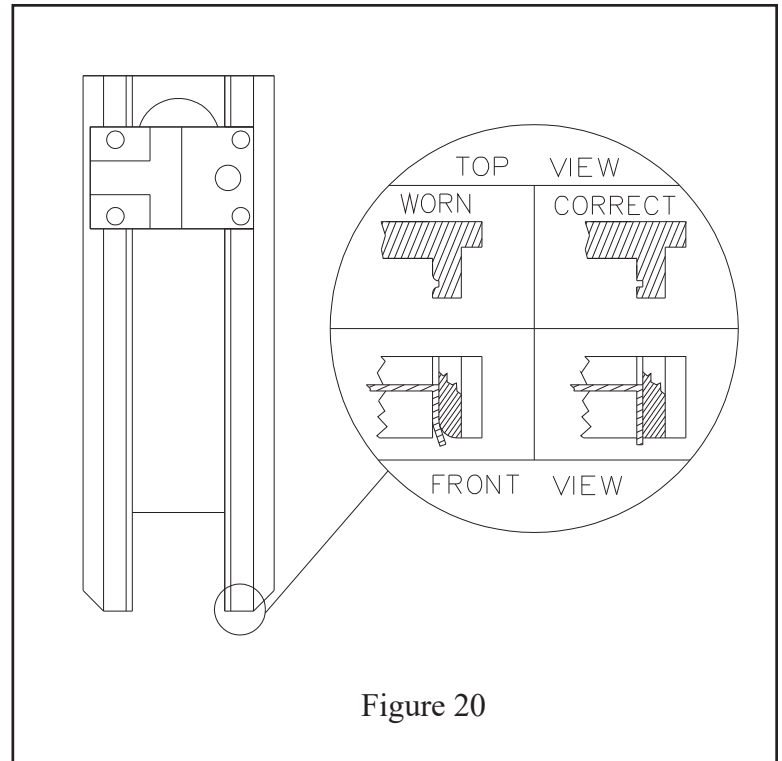

Figure 20

2. To adjust for side-to-side alignment: (Fig. 19)
  - a. Turn power off. Cycle the stitcher by hand until legs of the stitch appear just below the bender bar to determine how far the head or clincher should be moved to the side.
  - b. Loosen clincher plate binder nuts (Index A).
  - c. Move clincher to left or right as required.
  - d. Tighten binder nuts.

### **D. Bender Bar (Figure 20)**

The bender bar bends the wire over the rotator and forms it into an unclinched stitch. The legs of the stitch are guided towards the work material by the bender bar grooves. The legs of the unclinched stitch should be perpendicular to the crown. When the bender bar grooves become worn, the legs tend to flare out (Figure 20) as they emerge from the grooves. This causes the legs to strike the clincher improperly. As a result, one or both legs will crumple and a broken driver bar or a broken bender bar can result. If the lower end of the bender bar grooves become chipped, it will not support the wire and may cause the stitch to break at the crown. Replace the bender bar assembly (See "G" page 27 or Fig. 21). Other bender bar functions are related to wire cutting ("I" page 29), and driving ("F" page 26).

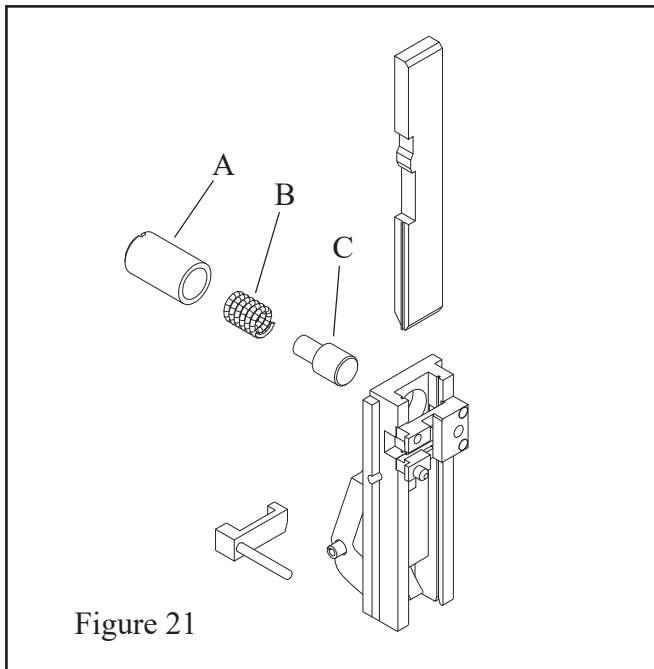

Figure 21

### **E. Bender Bar Friction Plug And/Or Spring (Fig.21)**

Two parts furnish pressure to coordinate movement of driver bar and bender bar. If pressure is insufficient, proper timing is not maintained for the action of the grip. As a result, wire feeds backwards. Replace the plug and/or spring.

To replace bender bar friction plug and/or bender bar friction spring:

1. Remove bender bar assembly by following steps 1 through 18 of "Dismantling The Stitching Head", Pages 33 and 34.
2. Remove bender bar friction bushing (Index A). Bender bar friction plug (Index C) and spring (Index B) will be released forward from bender bar assembly.
3. Replace plug and/or spring and reassemble.

### **F. Driver Bar (Figure 22)**

The driver bar (Index A) has several functions:

1. It imparts the downward thrust from the driving slide assembly (Index B) to the bender bar assembly (Index C).
2. It returns these parts to the neutral position on the upstroke.

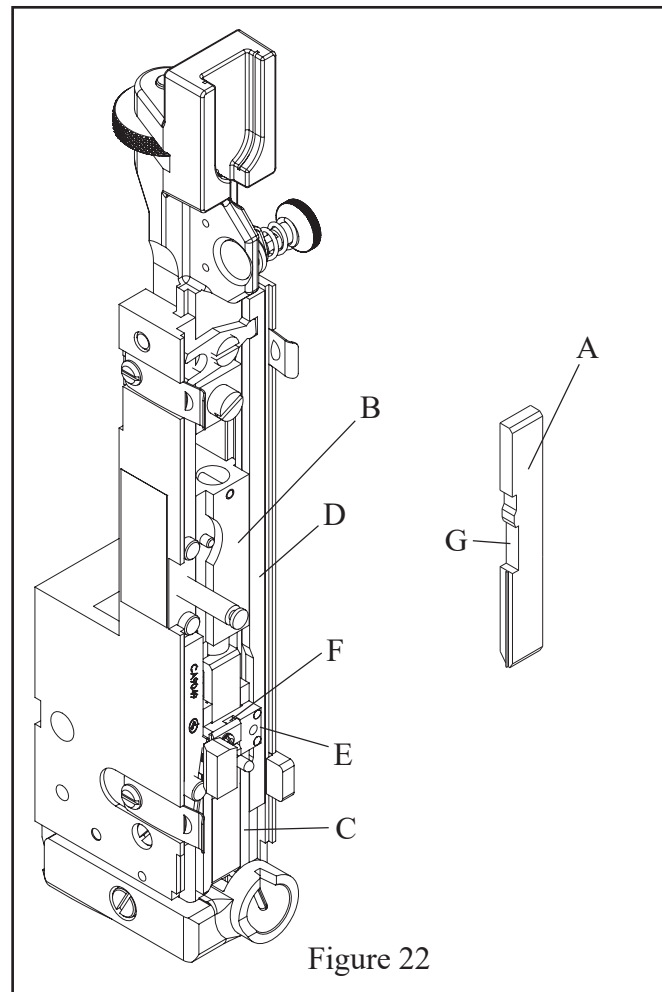

Figure 22

3. In conjunction with the grip release slide (Index D), it controls the movement of the bender bar latch (Index E) that opens and closes the grip (Index F).

If the notches (Index G) at the top left side of the driver bar become worn, the grip will not remain open on the upstroke. As a result the wire feeds backwards and buckles above the grip and below the tension pawl. Worn notches can also cause uneven wire draw. Replace the driver bar.

The notches shown on left side of driver bar play an important part in function of bender bar assembly therefore, corners should be free of dirt and notches not marred.

The driver bar rides within the bender bar grooves as part of the bender bar assembly. As this assembly reaches the lower contact point of the cam in the grip release slide, the bender bar latch is forced inward, releasing the wire grip and permitting the bender bar assembly to continue downward with the end of the driver riding on top of the formed

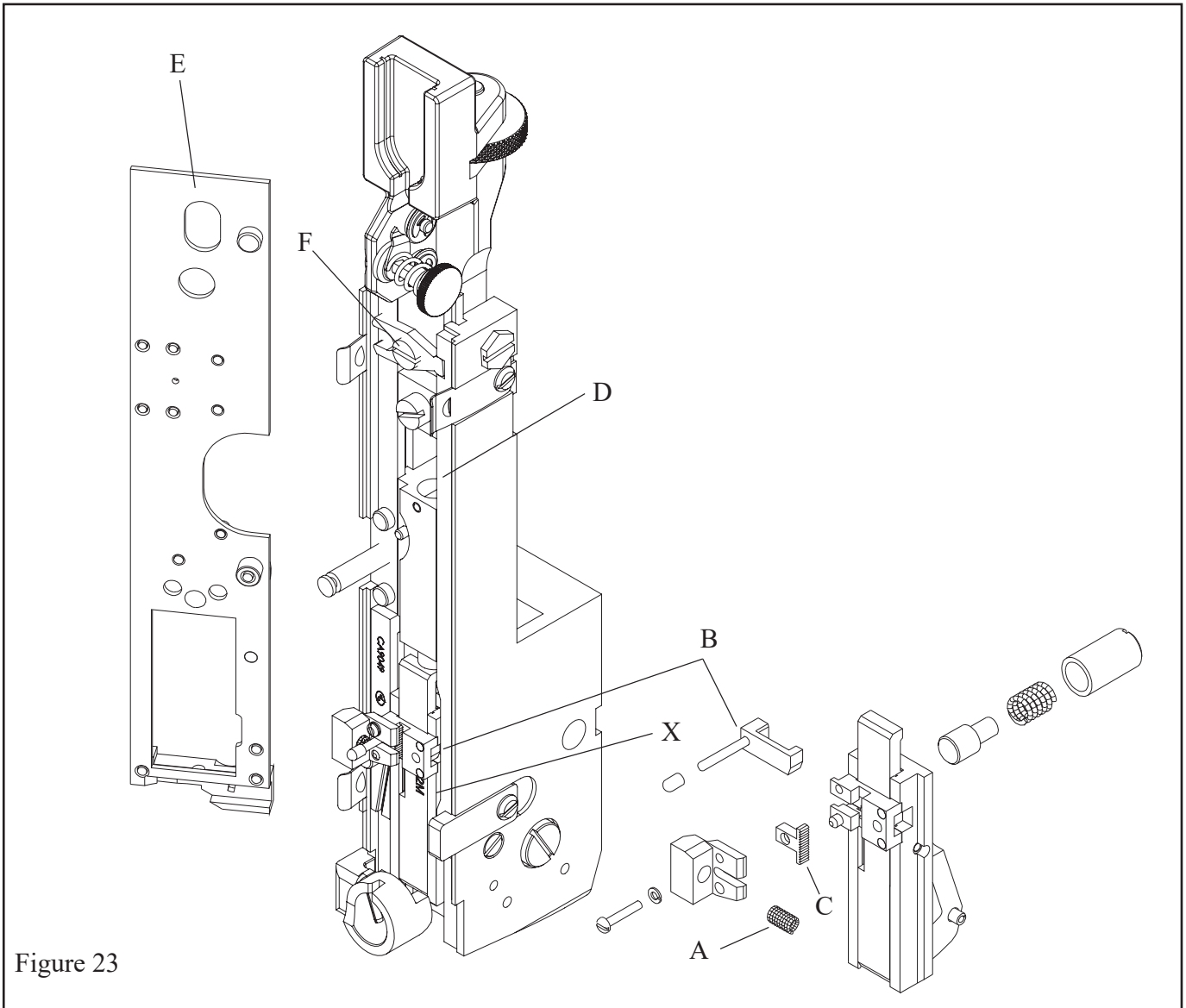

Figure 23

stitch. When the bender bar is stopped against the work material, the driver bar continues downward to exert pressure on the crown of the stitch, driving it through the work material.

If the end of the driver bar is chipped it allows the legs of the stitch to back up into the broken area. This causes the corner of the crown to fracture or a "spike" section to protrude above the crown. A chipped driver bar is usually the result of driving a stitch on top of another stitch. A worn driver often causes deformed stitches or fracturing at the corners of the crown.

### **G. Bender Bar Latch**

The bender bar latch opens and closes the grip and is actuated by the grip release slide and driver bar. If the contact points of the latch become worn, tim-

ing of the grip is erratic and uneven wire feed results. A dirty latch will decrease pressure of the grip on the wire. This causes wire slippage. Clean or replace the latch.

### **H. Grip, Grip Release Slide and Face Plate: (Figure 23)**

The grip spring (Index A) exerts pressure on the bender bar latch (Index B) to close the grip (Index C) at the start of the down stroke. The grip release slide (Index D) actuates the bender bar latch at point X to open the grip after the correct amount of wire has been fed to make a stitch. The serrated teeth on the grip must be sharp or slippage will occur, producing uneven wire draw.

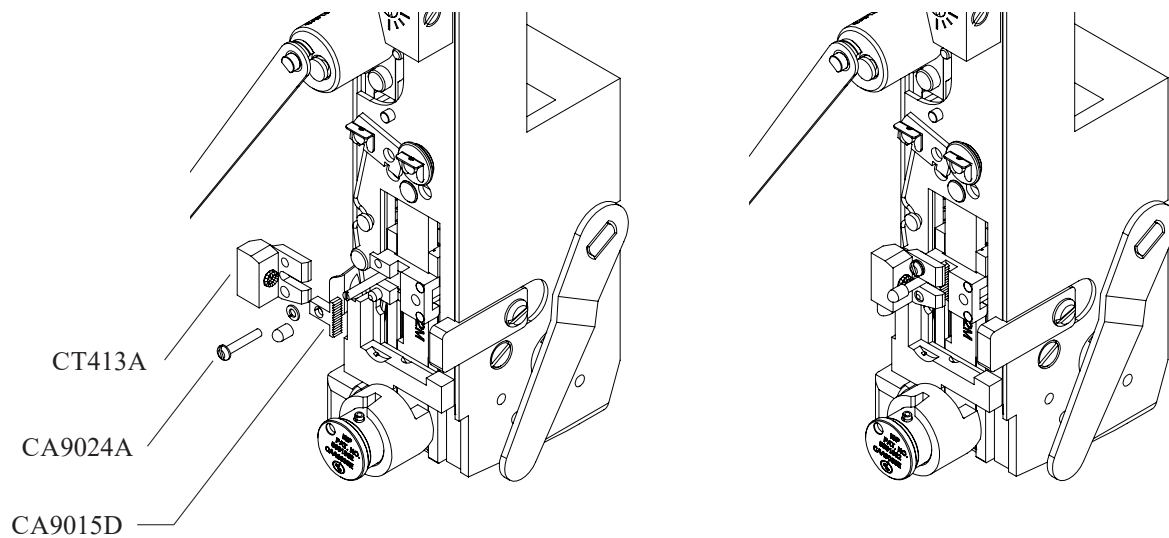

Figure 24 - **Replacing the Grip**



**Always disconnect the power supply before assembling the StitchMaster or making any adjustments.**

**Removing and Replacing the Tension Pawl (Figure 25)**

The Tension Pawl (CA9098) is double-ended so that when one end is worn, it can be reversed, increasing the life of the part by providing a new gripping surface. To remove the Tension Pawl, disengage the Tension Pawl Spring (CA9134) from the Tension Pawl and remove the Wire Straightener Roll Clip (CA9124). Flip the Tension Pawl over so that a new surface is in contact with Wire Straightener Roller (CA9103A) and replace the E-clip. Make sure that the Tension Pawl is under the flange in the Wire Straightener Roll before re-engaging the Tension Pawl Spring. If both ends of the Pawl are worn, replace the part.

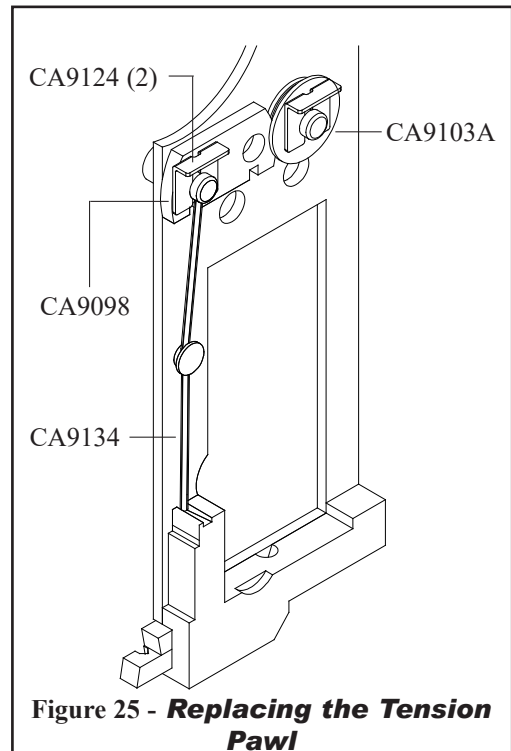

Figure 25 - **Replacing the Tension Pawl**

When the face plate (Index E) is adjusted (See "Changing Work Thickness", page 14) a pivotal action (at point F) changes the position of the grip slide. When the face plate is raised, it moves the grip release slide down. The gripper can then remain closed longer, on the down stroke, feeding more wire for the stitch. When the face plate is lowered, it moves the grip release slide up. The gripper will open sooner on the down stroke, feeding less wire for the stitch.

If the grip is weak, uneven wire draw will result. Replace the grip spring. If the contact points on the grip release slide and/or the bender bar latch are worn, wire adjustment will not remain accurate.

The face plate stops the bender bar assembly at the top of its stroke and allows the bender bar latch to close the grip. When the face plate is too high, too much of the upstroke has been used before the bender bar hits the face plate. In the remaining portion of the upstroke, the driver bar cannot continue upward enough to release the bender bar latch so that it can close the grip.

## **I. Wire Cutters: (Figure 26)**

The purpose of the wire cutters is to shear the wire cleanly. There are two wire cutters, upper and lower. The upper wire cutter (Index A) receives wire from the grip through the wire cutter lead-in-hole (Index B). It also serves as the cutoff die. The lower wire cutter (Index C) is the cutting knife. If the cutter breaks, it will cover the lead-in hole. This prevents the wire from feeding into the rotator. If the cutting surfaces become worn, burrs will result on the end of the wire. This prevents the wire from feeding into the rotator. As a result, the wire buckles between the cutters and the wire grip. Reverse, interchange or replace the cutters.

### **To Reverse, Interchange or Replace the Wire Cutters:**

1. Loosen both face plate retaining clips (Index D) at bottom of bonnet.
2. Spring the face plate out 1/8" while holding the cutter slide in position (Index E).
3. Slide the cutters out to the left.

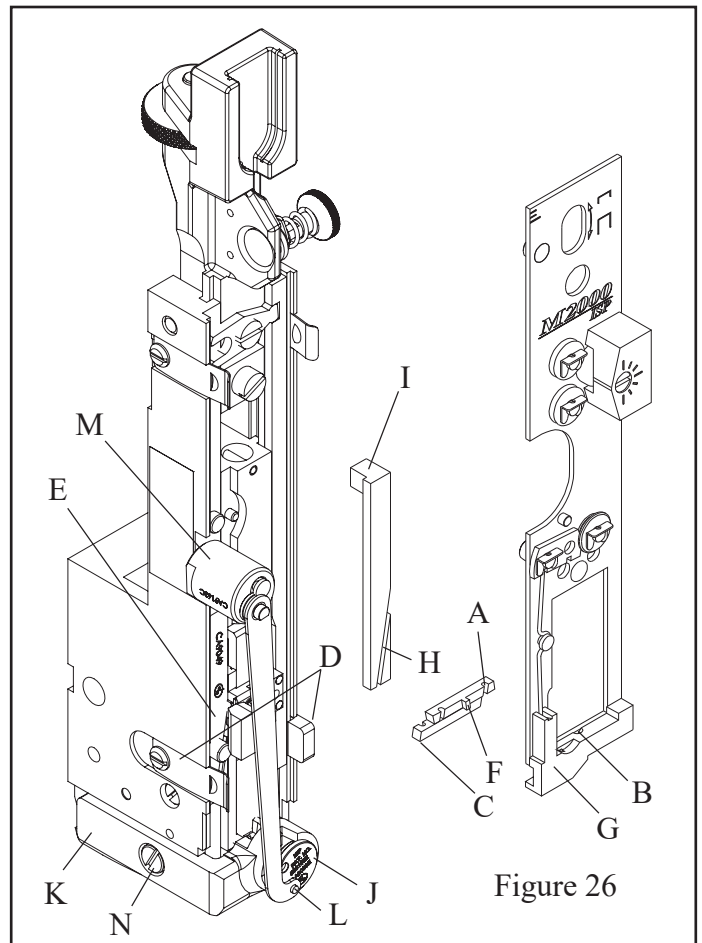

Figure 26

4. Reverse, interchange or replace the cutters.

## **NOTE**

While installing the cutters, make sure that (1): lip on upper cutter (Index F) fits into the recess behind the face plate (Index G) and (2): that the lip on the bottom cutter fits into the slot (Index H) in the wire cutter operating slide (Index I).

The wire cutter operating slide actuates the lower wire cutter. If the slide is worn or broken, the wire cutter is not actuated. Replace the operating slide. The slot in the lower part of the face plate contains the wire cutter and maintains a close fit for wire shearing. If this slot becomes oversized, the wire will not be cut off. Replace face plate. **To Replace Face Plate (See Steps 1 through 10, "J" page 30).**

## **NOTE: (Figure 27)**

**The lug (Index C) in the faceplate must match the slot (Index D) in the grip release adjusting lever (Index E) or damage to the head may result.**

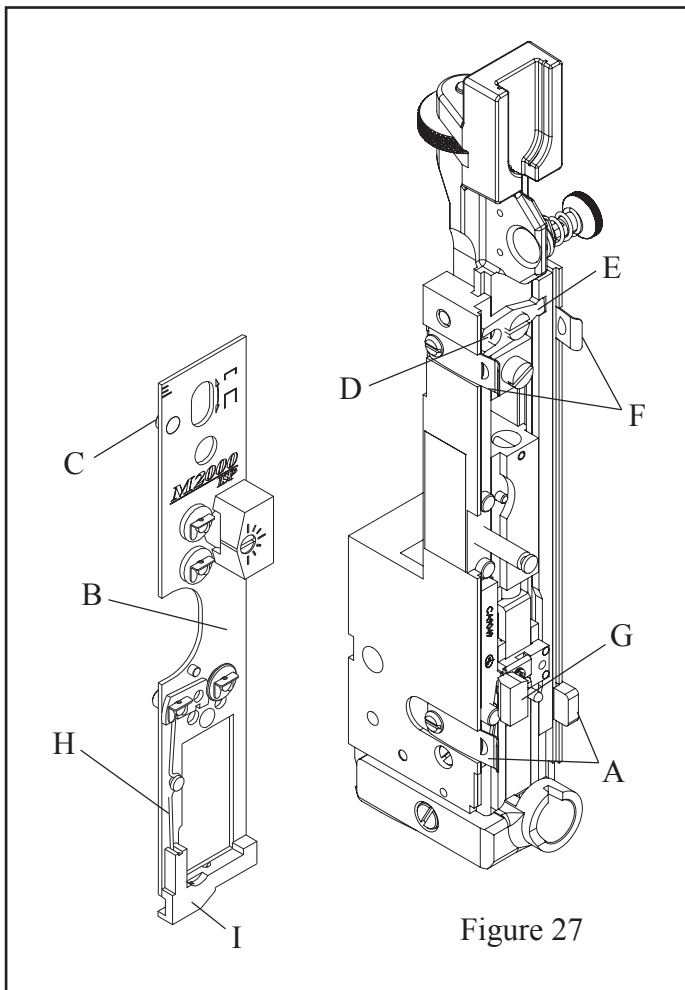

Figure 27

## J. Wire Cutter Operating Slide

The wire cutter operating slide actuates the lower wire cutter which acts as the cutting knife. If the slide is worn or broken, the wire cutter is not actuated. Replace the operating slide.

To Replace The Wire Cutter Operating Slide:

1. Cut the wire at the bracket and pull the loose end out.
2. Remove the stitcher head assembly.
3. Lift end of spring (Index L, Figure 26) out of rotator.
4. Swing the spring up to disengage it and lift out.
5. Slip the rotator operating cam (Index M, Figure 26) forward and off the stud.
6. Pull the rotator forward.
7. Loosen the two face plate retaining clips (Index A, Figure 27) and rotate them downward.

8. Push two face plate retaining clips (Index F) outward while lifting face plate up, or remove retaining clips to release face plate.
9. Position grip spring housing (Index G) between tension pawl spring retainer (Index H) and cutter housing (Index I).
10. Remove face plate (Index B) by sliding face plate to the left and lifting up.
11. Remove the cutter operating slide (Index I, Figure 27).
12. Insert a new cutter operating slide.
13. Reassemble

## K. Proper Wire

Depending on which M2000 head is being used the wire range may be: 25 to 30 gauge round; 24 gauge round; 20x25 or 21x25 flat. 120,000 to 159,000 psi tensile strength bookbinders wire should be used.

If the wire used is larger than the bender bar grooves were designed for, it will fracture at the stitch corners and come out in pieces. Also, serious damage to the stitcher may result. If the wire used is smaller than the bender bar grooves were designed for, the legs of the stitch do not fit snugly in the grooves and may tend to buckle when they strike the work material because they are not fully supported.

## L. Rotator (Figure 26)

The rotator (Index J) (1) receives the wire from the cutoff die, (2) holds the wire while it is being cut, then (3) turns it to a horizontal position, moves it under the bender bar grooves and (4) supports the wire while it is being formed into a "U-shaped" stitch.

The wire lead-in-funnel of the rotator must be aligned with the wire as it comes through the wire cutters. If the rotator is improperly aligned, the wire hits the rotator and buckles. Adjust upper two wire straighteners until wire slips past rotator. Burrs on the rotator prevent the wire from entering the rotator. This causes wire buckling. Remove the rotator and polish the lead-in radius.

The magnets in the rotator hold the wire firmly in the rotator. If a magnet is broken or chipped the wire may fall out. To determine if the rotator has the proper holding strength, remove the rotator and insert a cut length of wire in the rotator. Hold rotator between thumb and forefinger. Attempt to jar wire loose by hitting heel of hand on top of table or against other hand. With proper magnetic holding force wire will remain in rotator. With insufficient holding force wire will fall from rotator. Replace the rotator.

The rotator holder and rotator operating spring are responsible for alignment of the wire beneath the bender bar grooves. The position of the rotator holder determines how far the rotator is pushed forward under the bender bar by the rotator operating spring (Index L, Figure 26). A weak spring will not push the rotator in far enough and with this improper alignment the bender bar will knock the wire from the rotator or will shear the wire into pieces. To secure proper alignment, check the position of the rotator holder and the tension applied by the rotator operating spring. Make any necessary adjustment of the rotator holder or replace the rotator operating spring if weak.

The wire is fed into the rotator and held for forming. If the rotator is dirty, the wire is not gripped securely enough and drops out. Remove and clean the rotator. If the edges over which the wire is formed are sharp, the corners of the stitch crown will fracture. Remove the rotator and polish the edges with a fine emery cloth.

To remove, Adjust or Replace the Rotator Holder:

1. Swing the rotator operating spring to the left.
2. Remove the rotator.
3. Loosen the rotator holder screw (Index N, Figure 26).
4. Adjust the rotator holder.
5. Reassemble.

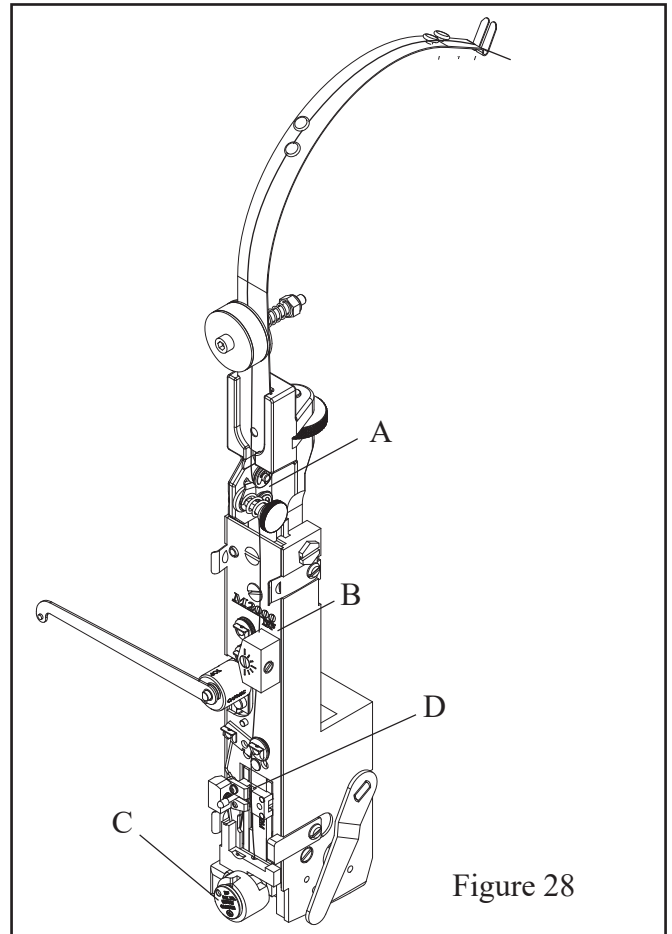

Figure 28

### ***M. Wire Straighteners: (Figure 28)***

All coils of stitching wire have a certain amount of bundle curve. The purpose of a wire straightener is to remove this curve. There is both an upper wire straightener (Index A) and a lower wire straightener (Index B) on all M2000 Model Stitchers. See "Threading Wire and Adjusting Wire Straighteners" page 11.

The upper wire straightener should feed wire parallel to the faceplate. This insures that the wire will properly enter the rotator and will be aligned with the grooves in the bender bar.

If the wire is not parallel to the face plate the wire is sheared in the rotator as the bender bar descends. Adjust the upper wire straightener.

The lower wire straightener directs the wire straight down so that it enters the rotator (Index C). If the wire is not straight enough it hits the rotator and buckles. Adjust the lower wire straightener so that

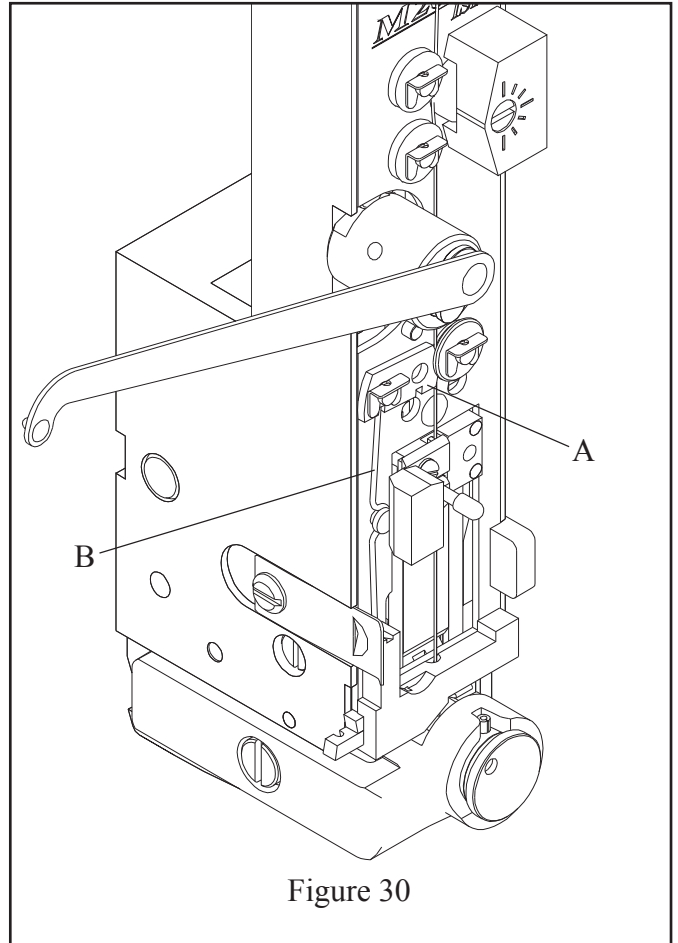
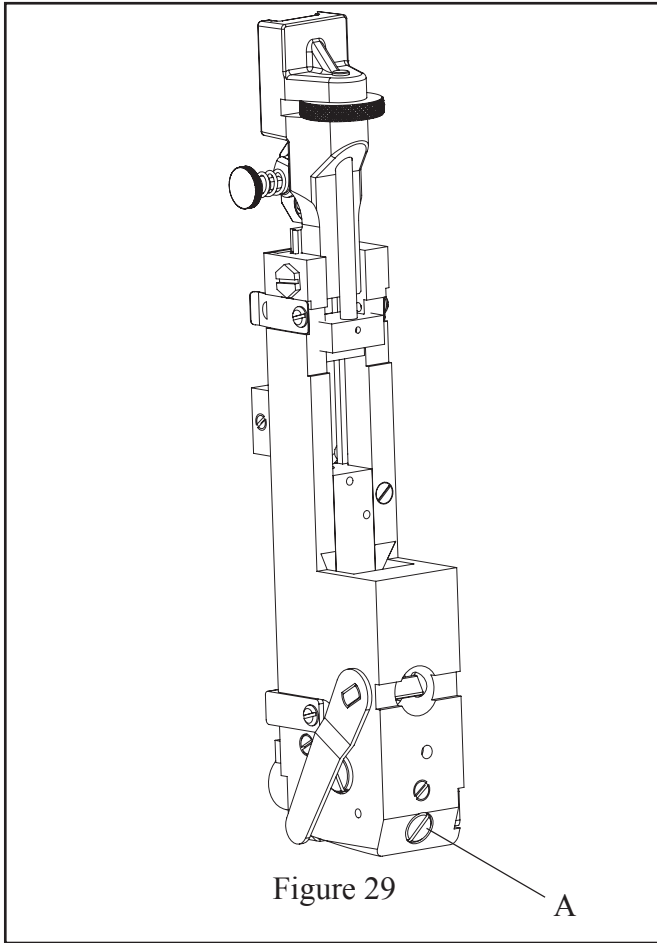

the wire points straight down as in figure 26. Improper straightening of the wire can also cause the stitch legs to buckle or turn out because they strike the clincher improperly. Excessive tension on the wire straightener prevents the grip (Index D) from feeding the wire smoothly. This causes variation in leg length.

**NOTE:**

Check the wire straighteners when changing the coils to insure the accurate feeding of wire.

**N. Supporter**

The supporter furnishes the necessary support to the inside surface of the stitch so that it does not buckle as it is being driven into the work material. A lack of (or insufficient) support will often cause the stitch crown to wrinkle or the legs of the stitch to buckle. Tighten the supporter spring bushing (Index A, Figure 29) or replace the spring.

If the corners of the top surface of the supporter are too sharp, or nicked, the corners of the stitch crown will fracture. If operating properly the supporter should function as follows:

1. When the bender bar touches the work material and the legs of the stitch are about to leave the bender bar grooves the supporter should be touching the underside of the crown.
2. As the stitch is driven through the work the supporter is gradually retracted by the driver. It should remain under the crown of the stitch until the last instant before the crown touches the work material.

**O. Tension Pawl: (Figure 30)**

The tension pawl (Index A) and spring (Index B) apply pressure on the wire to prevent back feed. If the pawl becomes worn or the spring becomes weak, the wire feeds backwards resulting in a short wire draw. Reverse or replace the tension pawl and/or spring.



# DISMANTLING THE STITCHING HEAD

**CAUTION!**

As a precautionary measure-When removing the head from any stitching machine make **SURE** that the power to the machine has been turned **OFF** or disconnected.

**CAUTION**

The rotator operating cam can be installed backwards. Be sure to read and follow the instructions "F" on page 21 before reassembling.

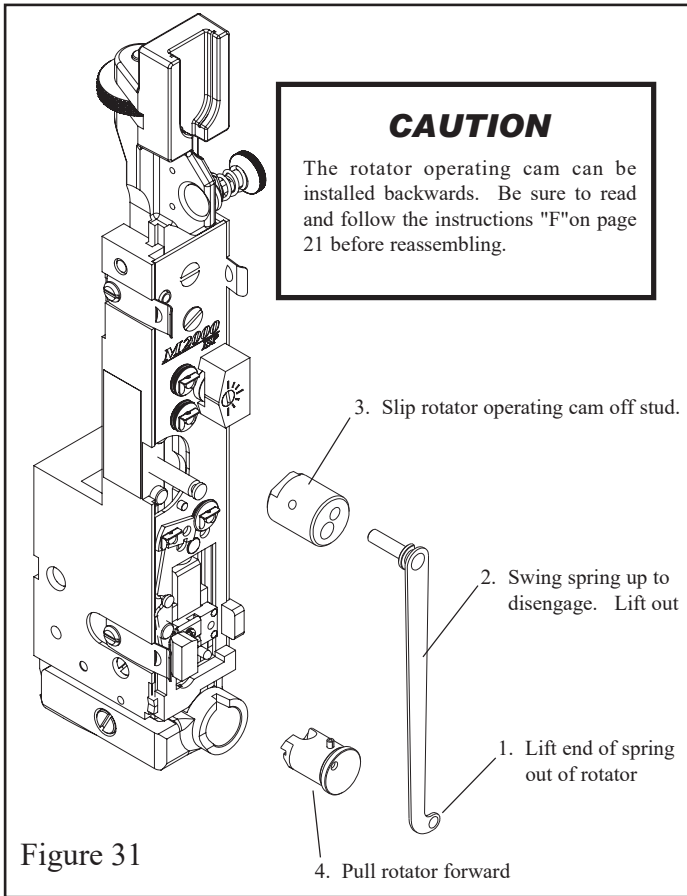

Figure 31

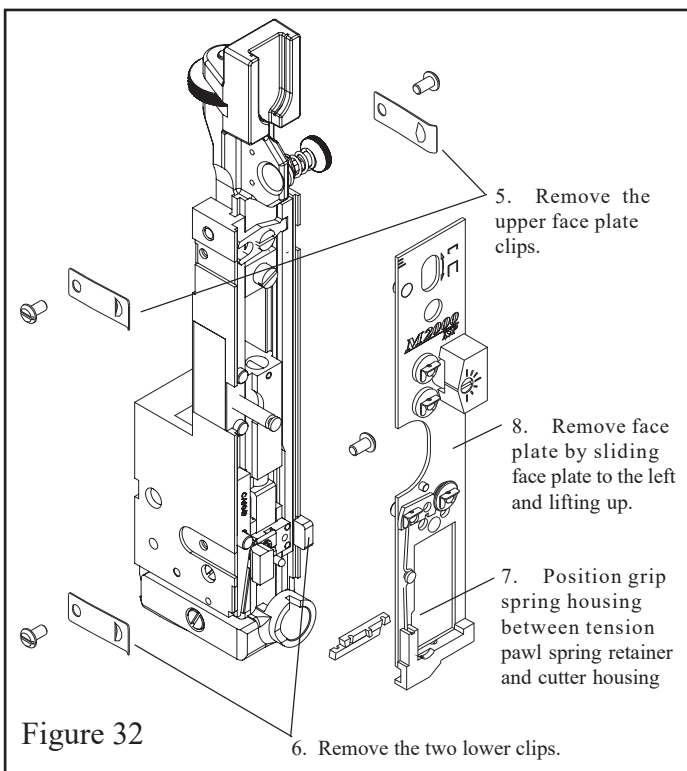

Figure 32

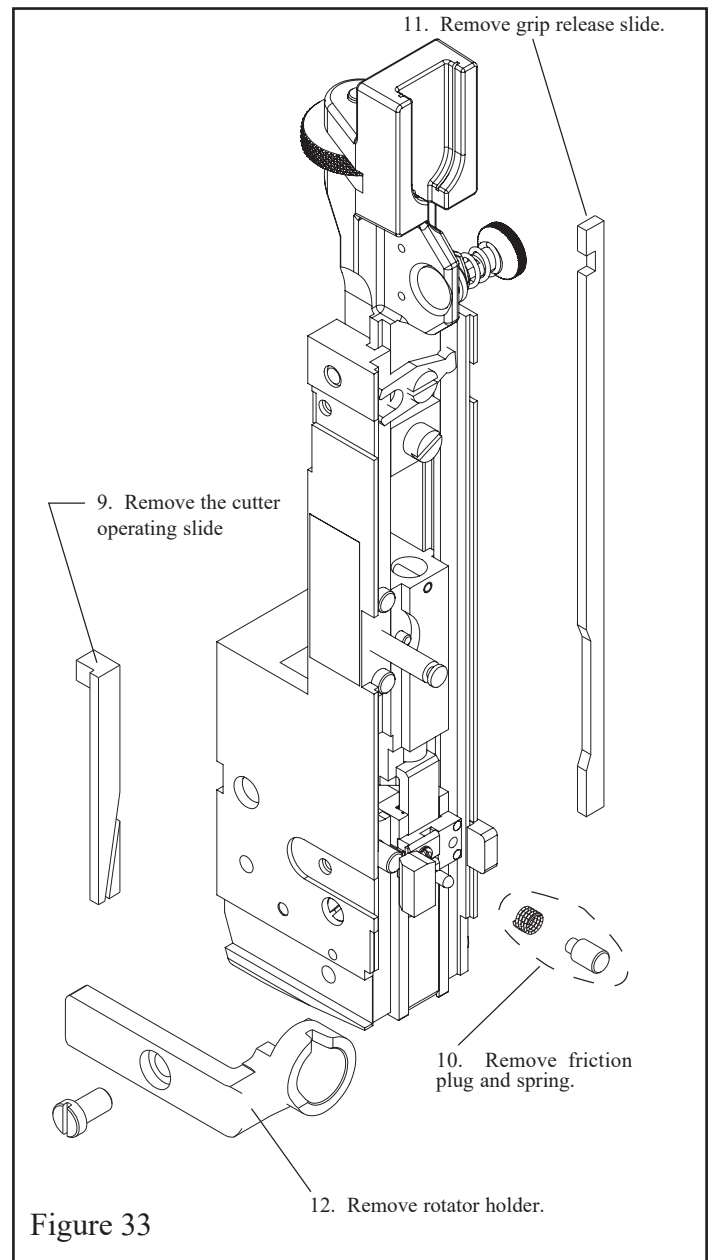

Figure 33

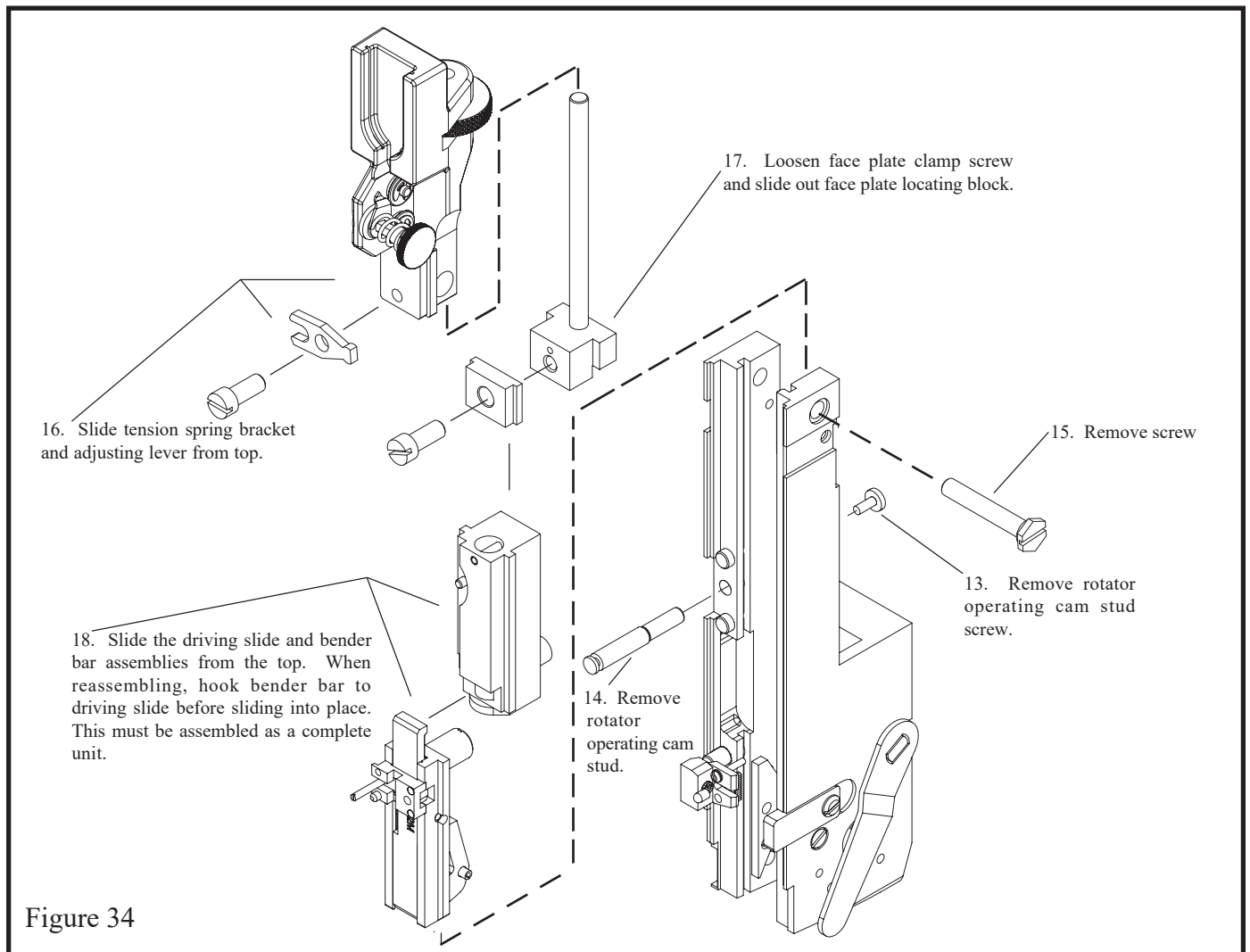

Figure 34

**DO NOT REMOVE OR ADJUST THESE TWO SCREWS.**

The screws are factory set to control the supporter lever location.

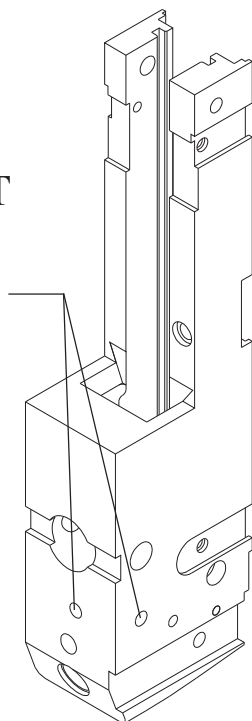

Figure 35

**Caution**

When reassembling, make certain that pin (Index A) is visible and is aligned with slot (Index B) of rotator operating cam (Index C). If not assembled in this way, the bonnet casting will crack or break on the next cycle under power. It is recommended that the stitcher be cycled by hand to test that proper reassembly procedure has been followed.

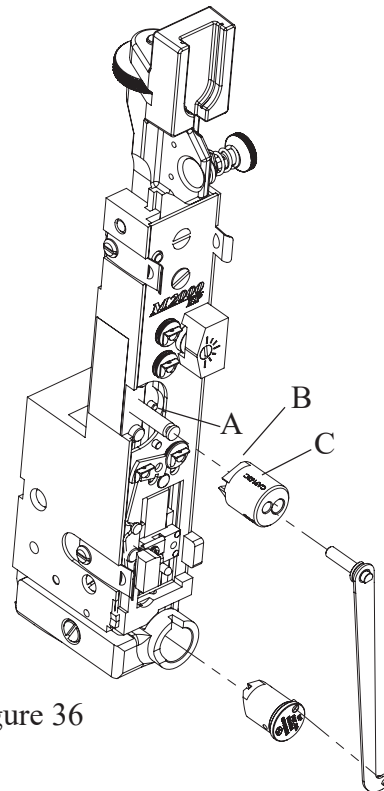
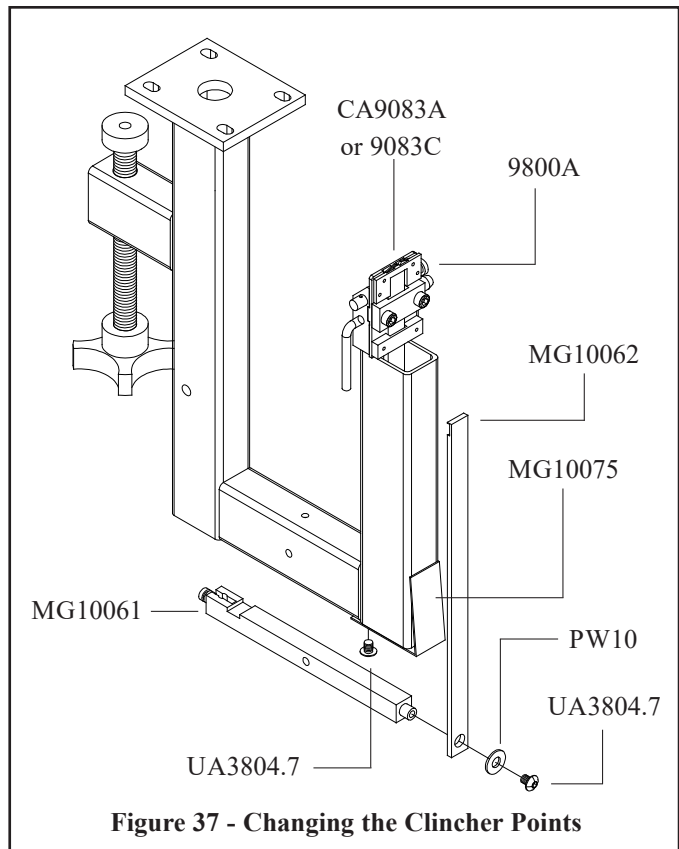

Figure 36

### **Changing the Clincher Points (Figure 37)**

The Clincher Points (CA9083A or 9083C) are double-edged and may be reversed when worn or chipped, which doubles their life. Loosen the Screw (UA3804.7) and rotate the Clincher Arm Cover (MG10075) until all internal components are visible. Release the Clincher Slide Retaining Screw (UA3804.7) and remove the Washer (PW10). Pull the Clincher Slide (MG10062) off the Clincher Lever (MG10061) and slip it out of the Clincher Plate (9800A). Swing the Clincher Points upward and pull them out of the Clincher Plate. Either reverse the existing Points or replace them with new Points. Insert the Clincher Slide back into the Clincher Plate and over the Clincher Lever. Replace the Washer and the Screw on the Clincher Slide and replace the Clincher Arm Cover with its Screw.



**Figure 37 - Changing the Clincher Points**

### **Replacing the Stitcher Head (Figure 38)**

Once the replacement parts have been installed or the existing wear parts have been reversed, the Stitcher HP Head can be mounted back on the StitchMaster HP. The following steps will make the process easier: Make sure that the upper end of the Driving Shaft Connection Link (2215) is attached to the Crank (MG10031A) with the oil hole up and the lower end is attached to the Driving Slide Pin (2103B). Position the Bonnet Clamp Eccentric (9003A) at an 11:00 position and slide the Head onto the Bonnet Clamp Block (9002) against the Head Mounting Plate (MG10026). Once the Head is lined up, pull the Bonnet Clamp Eccentric down, to approximately a 9:00 position, or until the Head is firmly fastened.

 <b>CAUTION!</b>
<b>Always disconnect the power supply before assembling the StitchMaster HP or making any adjustments.</b>

## Modifications

### Clincher Arm Adjustment (Figure 39)

All of the StitchMaster's adjustments, including the alignment, are set at the factory. However, sometimes it becomes necessary to change these adjustments. The Clincher Arm Alignment is probably the easiest of all the adjustments, but the most crucial. Without correct alignment, a good stitch can never be achieved. There are three separate adjustments necessary to align the Clinchers with the Stitcher Head.

Remove the Wire Spool (25G5 or 2125G5) and Cradle (MG10113) from the top of the StitchMaster HP. Release the StitchMaster HP from its work table or stand using the Clincher Arm Clamp Knob (P3793) and flip the entire StitchMaster over. Loosen the four Screws (CB487A) on the base of the Frame (MG10020A) to release the Clincher Arm (MG10052A). Align the groove in the Bender Bar (9013BA-25 or 9013BA-21x25) or the groove for the Driver (CA9009 or 9009-21x25) with the center of the Clincher Points (CA9083A or 9083C) in the Clincher Plate (9800A) by manually turning the StitchMaster HP over. Adjust the Clincher Arm to the correct position, checking both the side-to-side straightness and the front-to-back straightness. Once the correct position has been achieved, tighten the four screws on the base of the frame. The screws should be tightened slightly in a clockwise motion until the Arm is secure. Turn the StitchMaster HP back over and secure to the work table or stand.

Once the Clincher Arm is aligned with the Stitcher Head, the Clincher Plate Mounting Block (MG10063) can be better aligned. The two Screws (UA4808.3) securing the Clincher Plate Mounting Block can be loosened to allow the Mounting Block and Clincher Plate to be adjusted up or down. Ideally, the Clincher Plate should be touching the Driver when the Driver is at the lowest point of its stroke.

If even more fine tuning is necessary, the two Screws (UA3812.2) in front of the Clincher Strap (MG10060) can be loosened. These screws secure the Clincher Plate to the Clincher Plate Mounting Block. Once loosened, the Clincher Slide (MG10062) and Clincher Plate can be adjusted to the right or to the left to better align the Clincher Points with the Stitcher Head.

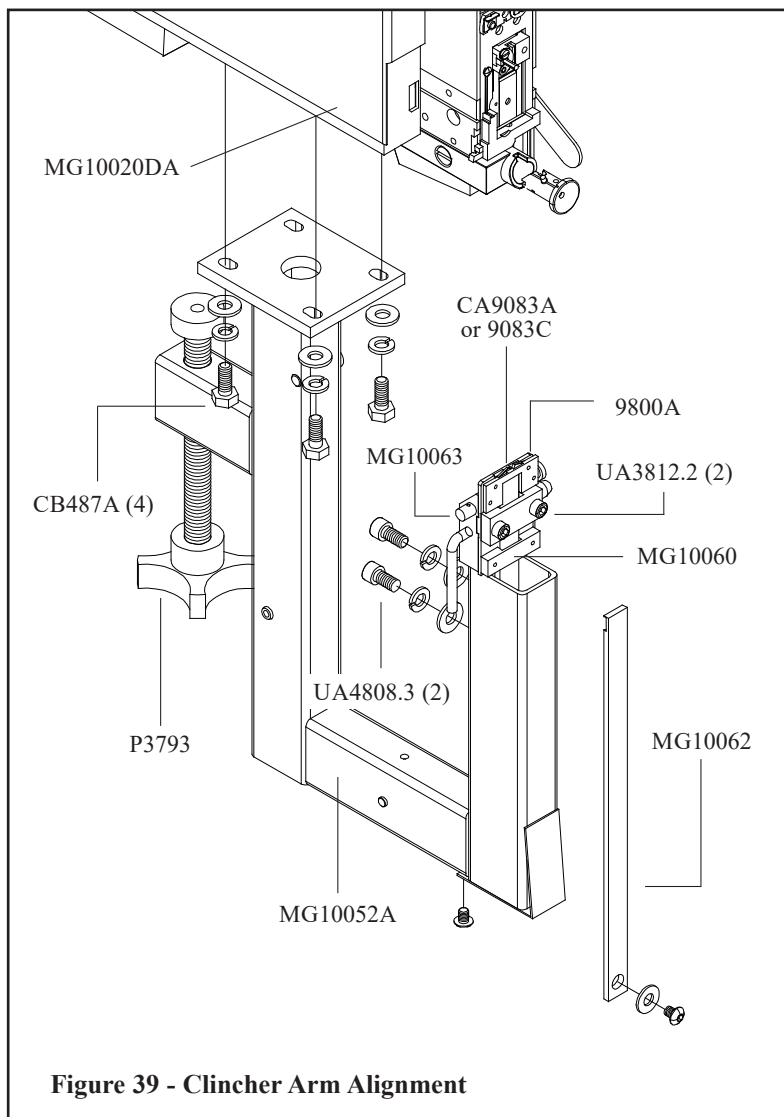

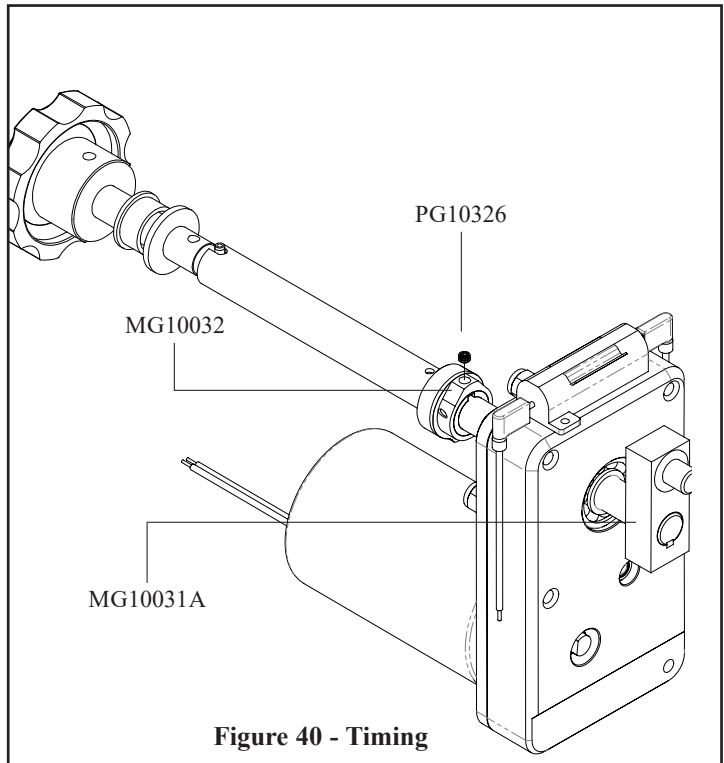

Figure 39 - Clincher Arm Alignment

**Always disconnect the power supply before making any adjustments or servicing the StitchMaster**  **WARNING!**

**Timing (Figure 40)**

The timing in a StitchMaster HP determines the knock-off point of the Crank (MG10031A). The timing is set before the StitchMaster HP leaves the factory, but the following instructions can be used if the timing has to be changed or re-adjusted. The end of the Crank closest to the gear box should stop at a position comparable to 11:00 or 12:00 o'clock. To adjust this position, loosen the Screw (PG10326) in the Control Cam (MG10032) and rotate it in the direction opposite to the way the Crank needs to move to stop between 11:00 or 12:00 o'clock. Trip the StitchMaster HP to double-check this position. Remember to tighten the Screw (PG10326) after the adjustments have been made.



# Appendices

## Exploded Drawings

### Frame Assembly

**NOTE:**  
*NOT all parts of the  
MG10014H Assembly  
is shown for clarity.*

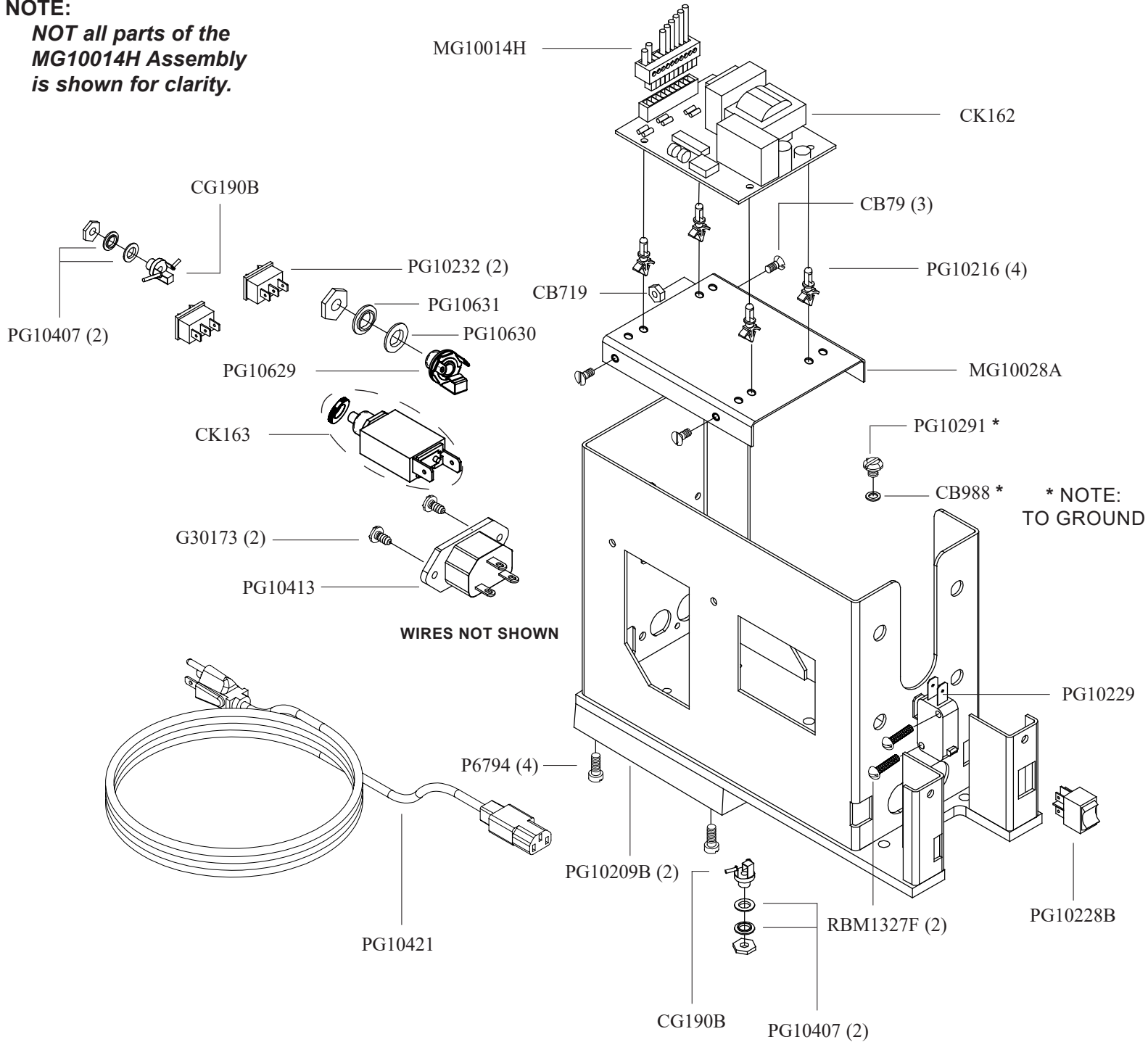

## **Frame Assembly Parts**

CB719	Nut 8-32	1
CB79	Screw 8-32 x 3/8	3
CB988	Shake Proof Lock Washer	1
CG190B	Phone Jack Plug	1
CK162	Circuit Board (115V)	1
CK163	Circuit Breaker Assembly	1
G30173	Self Tap Screw 8x3/8	2
MG10014H	Wiring Harness Assembly (115V)	1
MG10028A	Circuit Board Platform	1
P6794	Screw 10-24 x 5/8	4
PG10209B	Vibration Pad	2
PG10216	Circuit Board Spacer	4
CG190B	Phone Jack 141	2
PG10228B	On/Off Switch	1
PG10229	Snap Switch	1
PG10232	Trip Mode Switch	2
PG10291	Screw 10 - 24 x 1/4	1
PG10407	Shoulder Washer 1/4	4
PG10413	Plug Receptacle (115V)	1
PG10421	Power Cord (115V)	1
PG10629	Jack Receptical, .250	1
PG10630	Insulating Washer	1
PG10631	Shoulder Washer	1
RBM1327F	Round Head Screw, 4-40x1/2	2

## **Cam Switch Assembly**

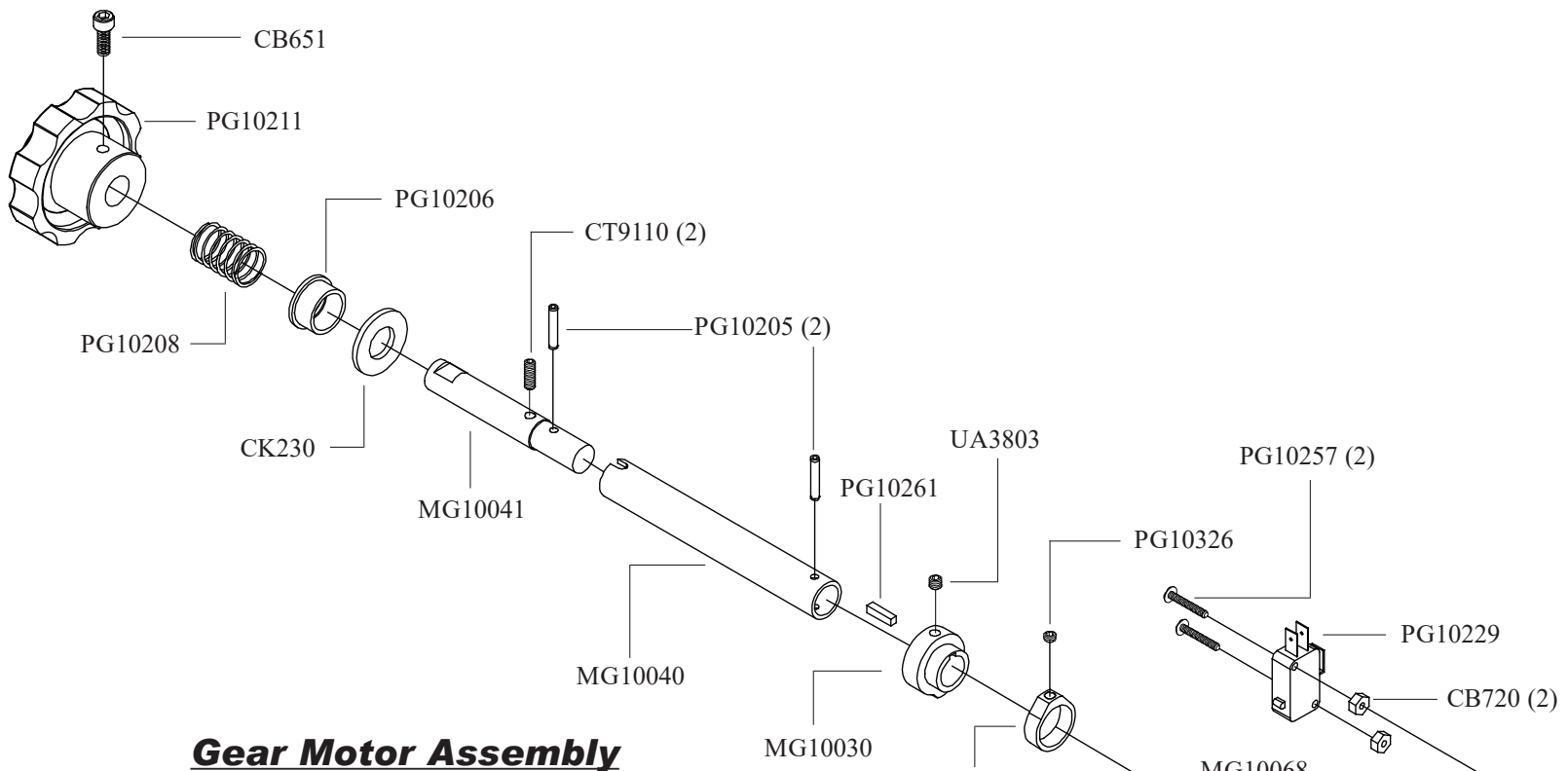

## **Gear Motor Assembly**

070836	Dowel, M4x8mm	1
CB371A	Lock Washer 1/4"	1
CB493	Nut 1/4 - 20	1
CB651	Screw 10-32 x 1/2	1
CB720	Nut 6-32	2
CK230	Washer, Steel .030" Thick	1
CT9110	Screw 8-32 x 1/2	2
MG10027	Cam Switch Mounting Plate	1
MG10030	Clincher Cam	1
MG10032	Control Cam	1
MG10040	Shaft Extension Tube	1
MG10041	Shaft Extension	1
MG10067	Cam Lever	1
MG10068	Cam Roller	1
MG10069	Cam Lever Spacer	1
PG10205	Spirol Pin 1/8x3/4	2
PG10206	Nylon Bushing 9/16	1
PG10208	Shaft Extension Spring	1
PG10211	Shaft Extension Handle	1
PG10229	Snap Switch	1
PG10257	Round Head Screw, 4-40x1/2	2
PG10238	Cam Roller Screw	2
PG10261	Square Key 1/8 x 1/2	1
PG10326	Screw, 8 - 32 x 1/8	1
UA3803	Screw 10 - 32 x 3/16	1
UA3806.3	Screw 10 - 32 3/8	3

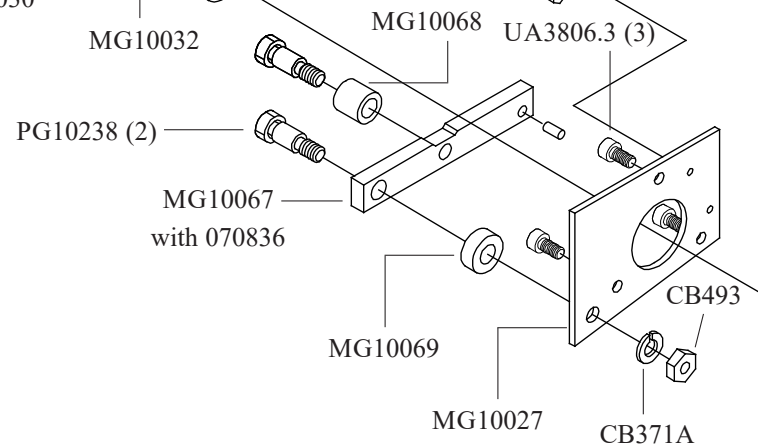



# **Gear Motor Assembly**

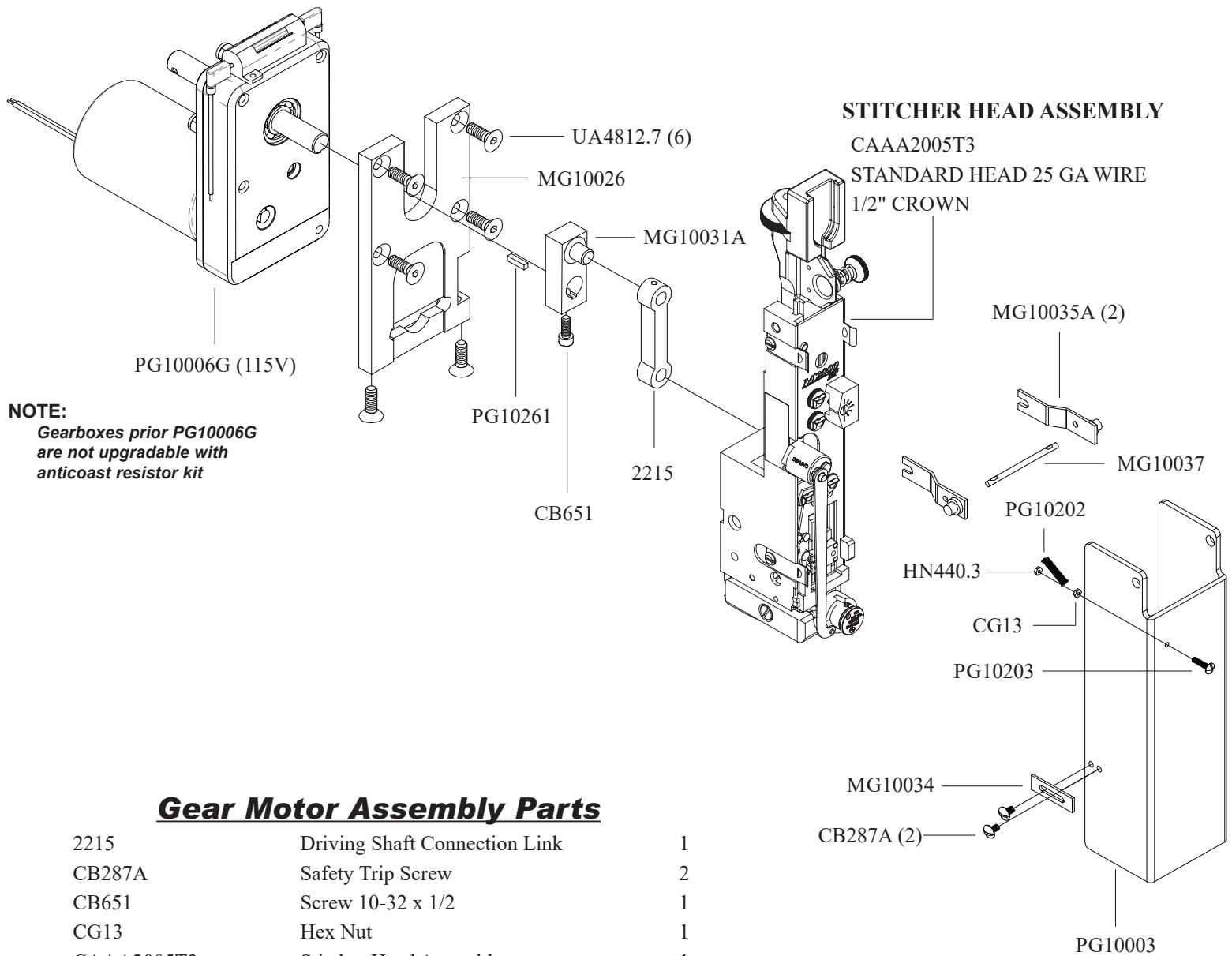

**NOTE:**  
Gearboxes prior PG10006G  
are not upgradable with  
anticoast resistor kit

## **Gear Motor Assembly Parts**

2215	Driving Shaft Connection Link	1
CB287A	Safety Trip Screw	2
CB651	Screw 10-32 x 1/2	1
CG13	Hex Nut	1
CAAA2005T3	Stitcher Head Assembly	1
HN440.3	Nylon Insert Lock Nut	1
MG10026	Head Mounting Plate	1
MG10031A	Crank Assembly	1
MG10034	Safety Trip	1
MG10035A	Guard Arm Assembly	2
MG10037	Guard Spring Rod	1
PG10003	Head Guard	1
PG10006G (115V)	Gear Motor - 115V	1
PG10202	Tension Spring	1
PG10203	Screw 4-40x1/2	1
PG10261	Square Key 1/8 x 1/2	1
UA4812.7	Screw 1/4 - 20 x 3/4	6

# Clincher Arm Assembly - Assembly Part Number MG10051A

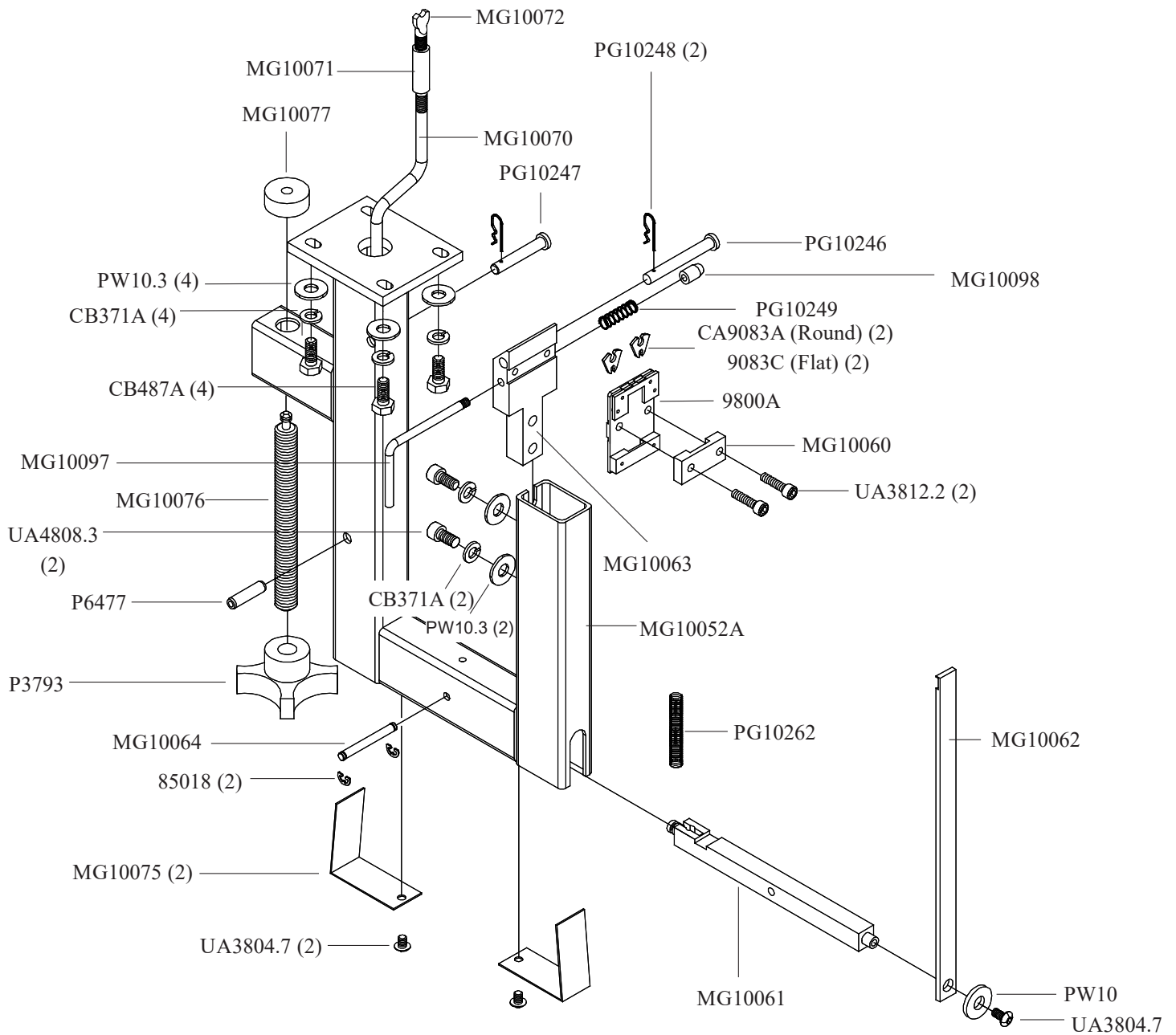

## **Clincher Arm Assembly Parts**

85018	Wire Straightener Roll Clip	2
9083C (Flat)	Clincher Point	2
9800A	Clincher Plate - Movable	1
CA9083A (Round)	Clincher Point	2
CB371A	Lock Washer 1/4"	6
CB487A	Screw 1/4-20 x 5/8	4
MG10052A	Clincher Arm	1
MG10060	Clincher Slide Strap	1
MG10061	Clincher Lever	1
MG10062	Clincher Slide	1
MG10063	Clincher Plate Mounting Block	1
MG10064	Clincher Lever Pivot Pin	1
MG10070	Clincher Rod	1
MG10071	Clincher Rod Sleeve	1
MG10072	Clincher Rod Stud	1
MG10075	Clincher Arm Cover	2
MG10076	Clincher Arm Clamp Rod	1
MG10077	Clincher Arm Clamp Pad	1
MG10097	Front Table Adjustment Handle	1
MG10098	Work Table Adjustment Nut	1
P3793	Clincher Arm Clamp Knob	1
P6477	Clincher Lever Spring Pin	1
PG10246	Front Table Pivot Pin	1
PG10247	Clevis Pin 1/4x1-1/2	1
PG10248	Table Pivot Pin Clip	2
PG10249	Front Table Adjustment Spring	1
PG10262	Clincher Lever Spring	1
PW10	Washer #10	1
PW10.3	Washer 3/16	6
UA3804.7	Screw 10-32x1/4	3
UA3812.2	Screw 10 -32 x 3/4	2
UA4808.3	Screw 1/4 - 20 x 1/2	2

# Tables and Trip Assemblies

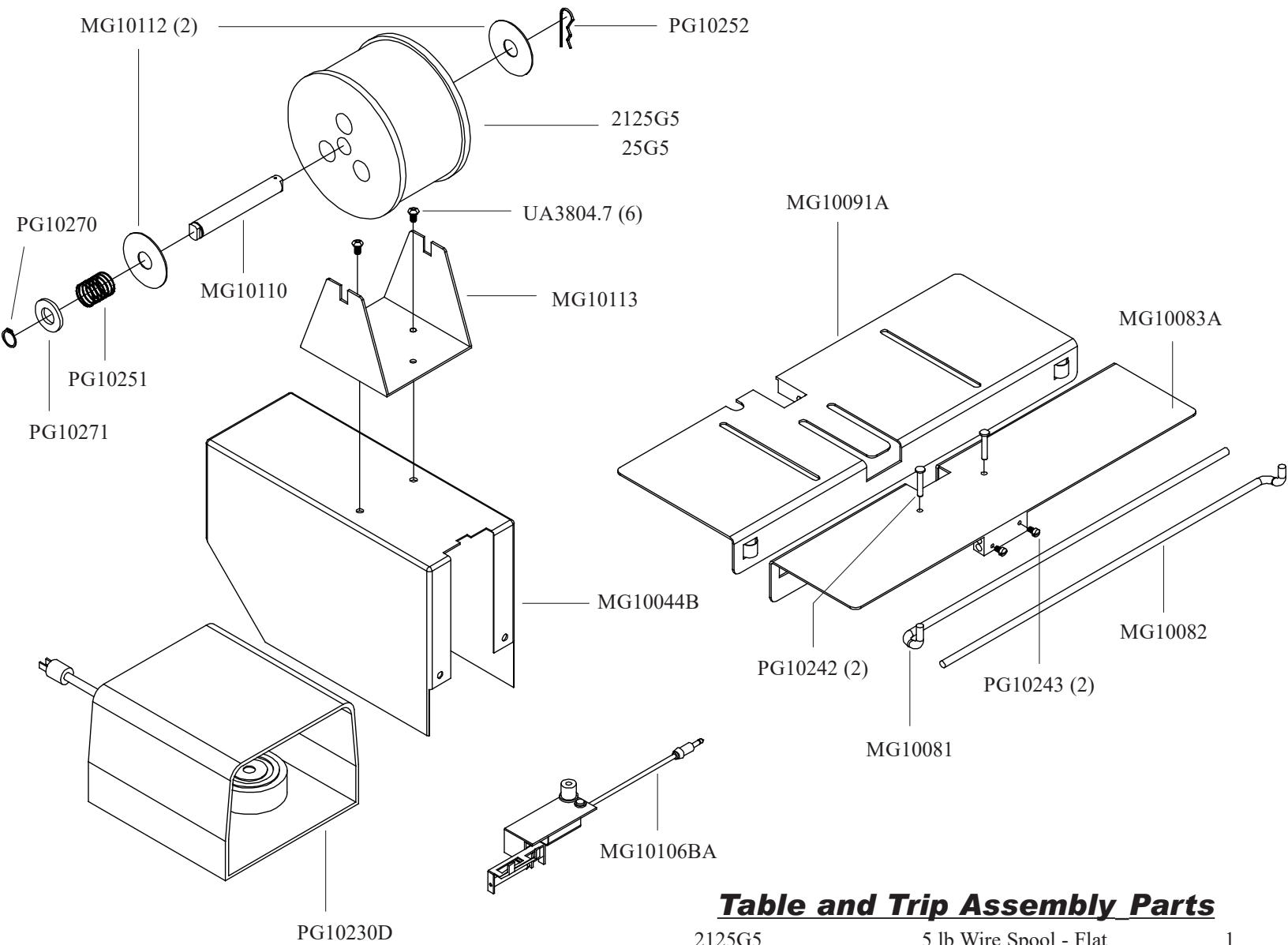

## WIRE SPOOL AND WIRE GUIDE SPRING SETUP FOR FLAT WIRE

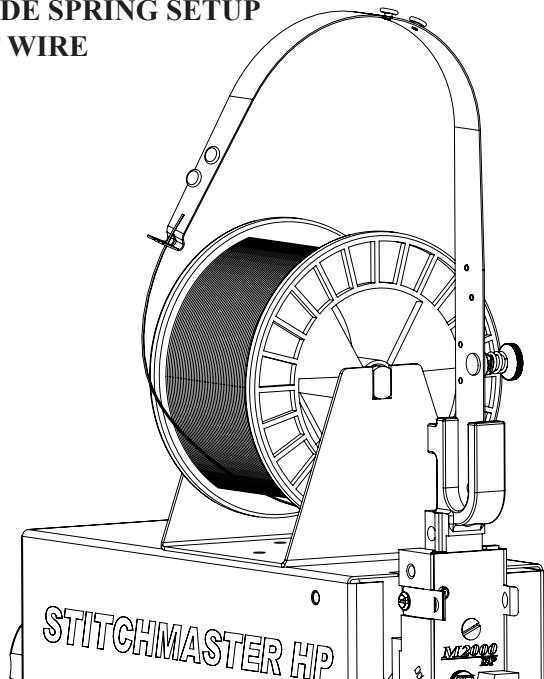

## Table and Trip Assembly Parts

2125G5	5 lb Wire Spool - Flat	1
or		
25G5	5 lb Wire Spool - Round	1
MG10044B	Cover	1
MG10081	Left Side Stop Rod	1
MG10082	Right Side Stop Rod	1
MG10083A	Front Work Table Assembly	1
MG10091A	Rear Work Table Assembly	1
MG10106BA	Trip Switch Assembly	1
MG10110	Spool Shaft	1
MG10112	Wire Spool Washer	2
MG10113	Wire Spool Cradle	1
PG10230D	Foot Switch w/ Guard	1
PG10242	Self Lock Pin 3/16x1	2
PG10243	Stop Rod Screw	2
PG10251	Spool Friction Spring	1
PG10252	Spool Clip	1
PG10270	Retaining Ring	1
PG10271	Washer 9/16	1
UA3804.7	Screw 10-32x1/4	6

# Face Plate Assembly

## Face Plate Assembly Parts

CAAA2132W

CA172	Screw, Set, Nylon Tip	1
CA9048	Wire Cutter	2
CA9065A	Wire Straightener Roll	1
CA9066A	Wire Straightener Eccentric	1
CA9098	Tension Pawl	1
CA9103A	Wire Straightener Roll	1
CA9103C	Wire Straightener Roll	2
CA9124	Wire Straightener Roll Clip	4
CA9134	Tension Pawl Spring	1
CAAA2132W	Face Plate	1

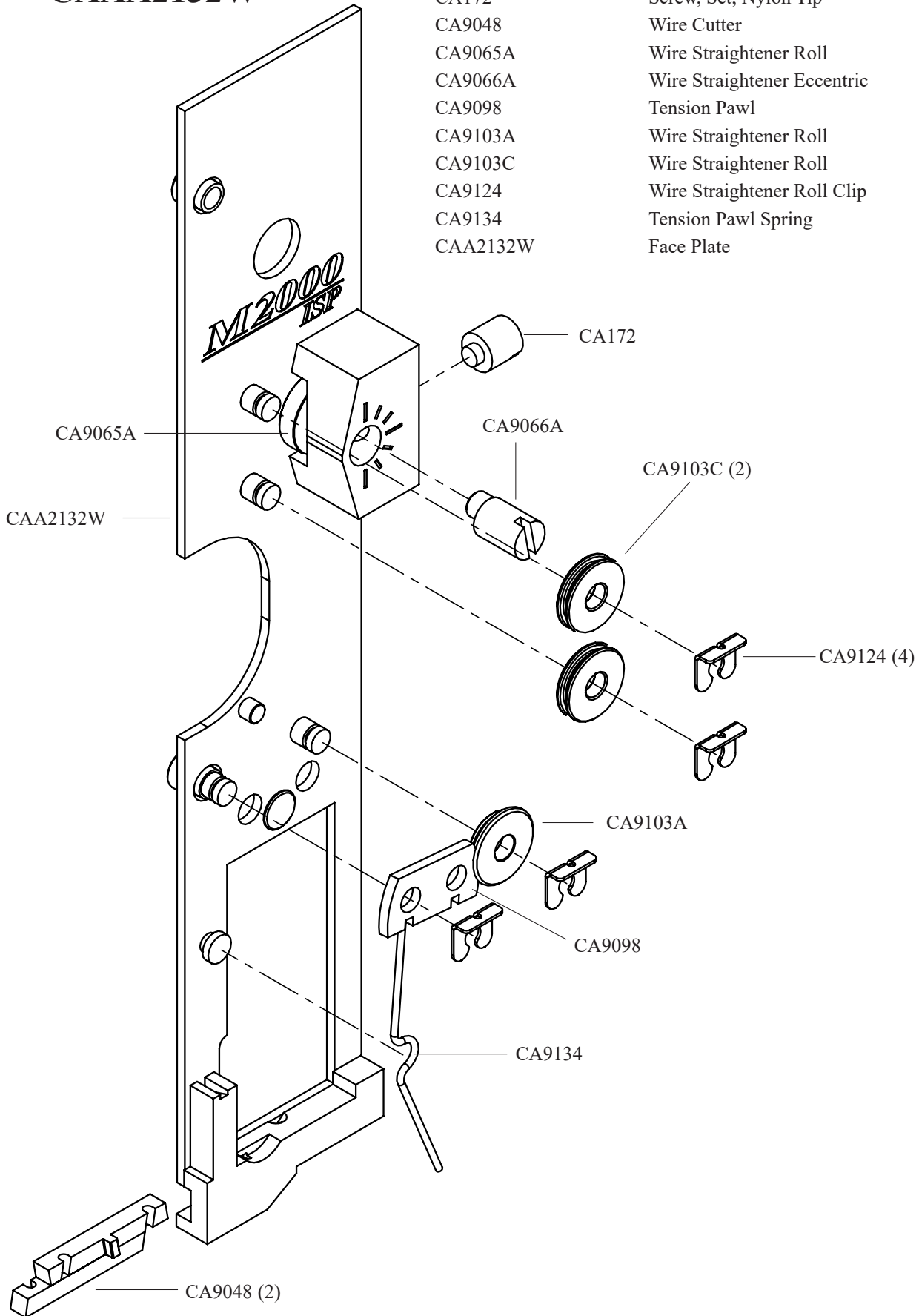



## **Stitcher Head - Bonnet Assembly**

CA156	Socket Set Screw - Flat Point	1
CA157	Socket Set Screw - Brass Point	1
CA2081	Face Plate Clip Screw	4
CA9022J	Grip Release Slide - 1/2 Cr	1
CA9025	Grip Release Slide Adj Lever	1
CA9030	Supporter Guide Plate	2
CA9032C	Compression Spring	1
CA9034	Supporter Spring Lever Screw	1
CA9037	Supporter Spring Lever Bushing	1
CA9043L	Rotator Holder, M2000	1
CA9044A	Swivel Holder Screw	1
CA9048	Wire Cutter	2
CA9049	Wire Cutter Operating Slide	1
CA9056C	Face Plate Retaining Clip	3
CA9056D	Face Plate Retaining Clip	1
CA9058	Swivel Operating Lever Screw	1
CA9075	Wire Guide Spring Bracket Screw	1
CA9081	Supporter Guide Plate Screw	2
CA9127	Swivel Operating Lever Stud	1
CA9163C	Swivel Operating Lever Cam	1
CAA9038E	Rotator Assembly 1/2 Cr, M2000	1
CAA9036	Supporter Spring Lever Assembly	1
CAA9046D	Rotator Operating Spring Assembly	1
CK213	Screw, 4-40 x .500 Hex Socket Set Screw	1
CT2604	Bonnet	1
CT9109	Bonnet Aligning Screw	1
CTT9002	Bonnet Clamp Assembly	1
CTT9003C	Bonnet Clamp Eccentric Handle	1
DBS1132	Sticker - 26A Head Swivel Replace	1

# Wire Guide Spring and Bender Bar Assemblies

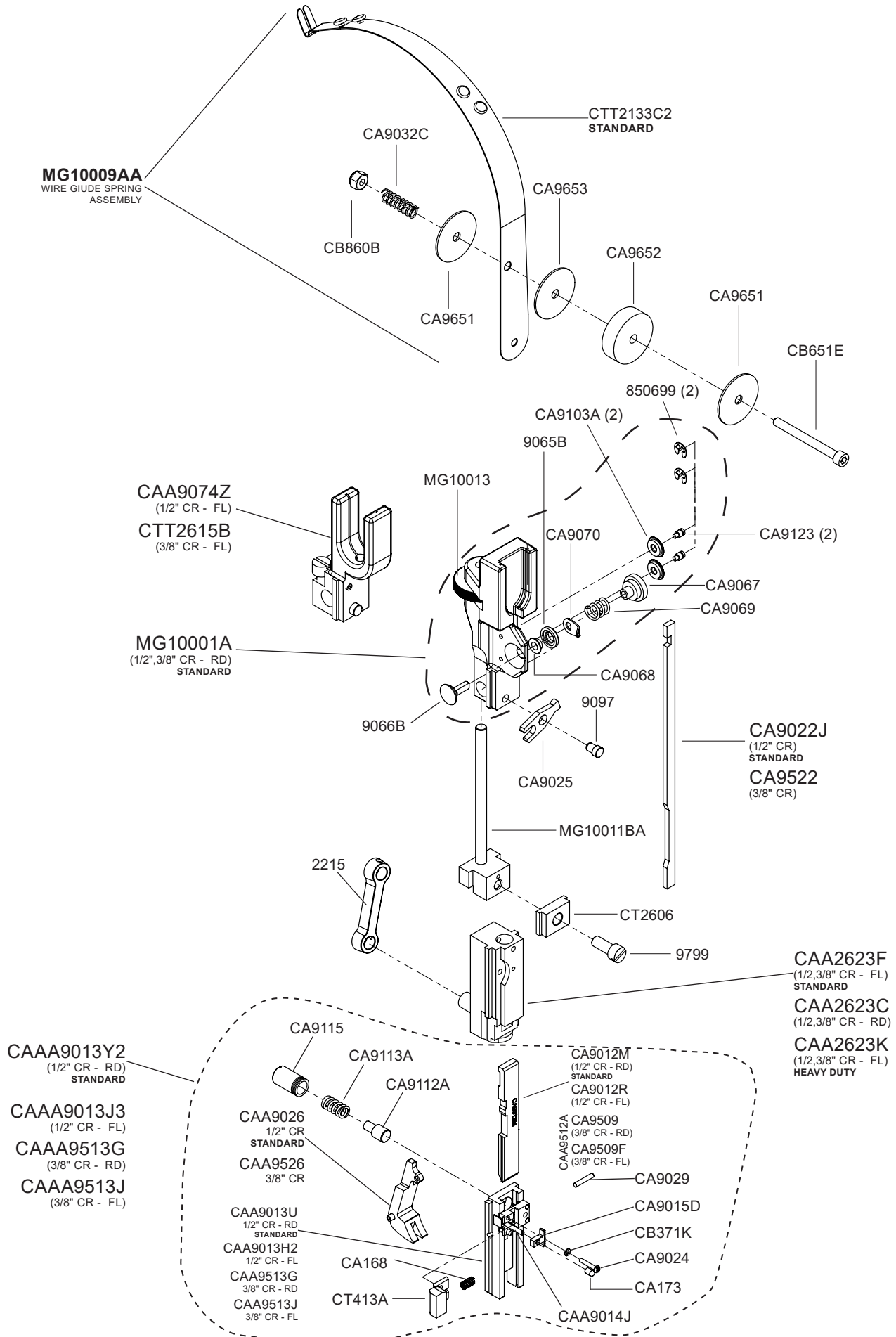



## **Wire Guide Spring and Bender Bar Assembly Parts**

2215	Driving Shaft Connection Link	1
9097	Grip Release Lever Pin	1
9799	Face Plate Locating Screw	1
CA9022J	Grip Release Guide, 1/2 CR	1
CA9025	Release Slide Lever	1
CA9522	Grip Release Guide, 3/8 CR	1
CAA2623F	Driving Slide Assembly, 1/2-3/8 CR, FL Wire	1
CAA2623C	Driving Slide Assembly, 1/2-3/8 CR, RD Wire	1
CAA2623K	Driving Slide Assembly, 1/2-3/8 CR, FL Wire, Heavy Duty	1
CAA9074Z	Wire Guide Spring Bracket Assembly, 1/2 CR, Flat Wire	1
CAAA9013Y2	Bender Bar Assembly, 1/2 CR, RD Wire, M2000	1
CAAA9013J3	Bender Bar Assembly, 1/2 CR, FL Wire,	1
CAAA9513G	Bender Bar Assembly, 3/8 CR, RD Wire,	1
CAAA9513J	Bender Bar Assembly, 3/8 CR, FL Wire,	1
CT2606	Face Plate Lock Clamp	1
CTT2615B	Wire Guide Spring Bracket Assembly, 3/8 CR, Flat Wire	1
MG10001A	Wire Guide Spring Bracket Assembly, 1/2 and 3/8 CR, Rd Wire	1
MG10009AA	Wire Guide Spring Complete Assembly	1
MG10011BA	Face Plate Adjustment Slide Assembly	1

# Wiring Schematic

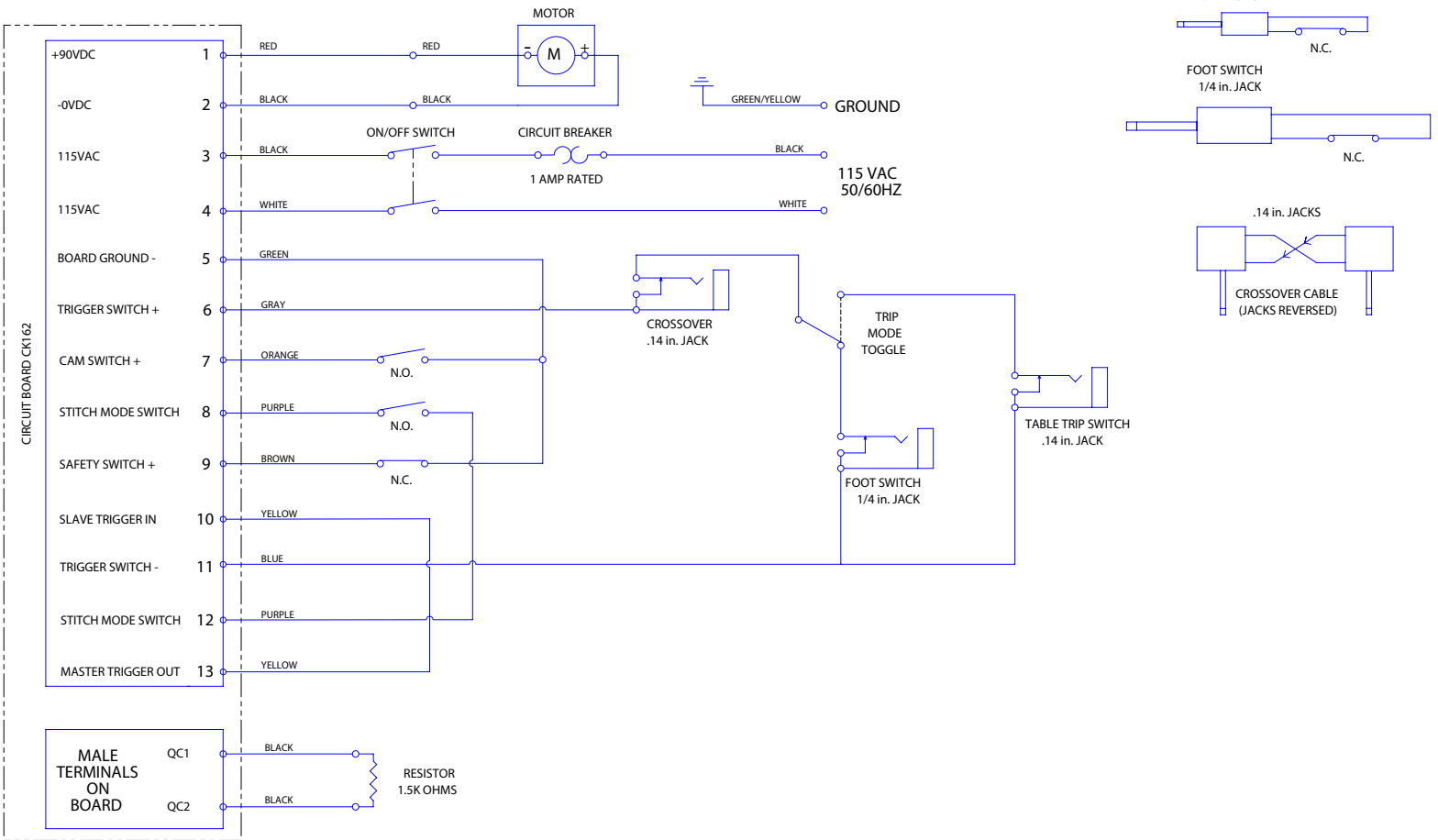

## Optional Equipment

In addition to the standard features offered with the StitchMaster HP, optional equipment items can be purchased to better accommodate your stitching needs. The following kits can be purchased from your Graphic Arts Representative.

### FSK1

This heavy duty Floor Stand allows you to place your StitchMaster HP wherever it is needed and adjusts from 28" to 42", securely mounting your StitchMaster HP. The Floor Stand Kit comes complete with easy to follow instructions and all the parts needed for assembly.

Place the Base Weldment (MG10131A) on the floor with the three screw holes up. Use the Leveling Screw (P6110) on the bottom right leg to level the Base. Attach the Post Weldment (MG10132A) using the three Screws (P9132) and Lock Washers (LW12.2) provided. Place the Slide Weldment (MG10133A) over the Post and lock it into the desired position using the Clamp Handle (MG10155). To finish, attach the four (4) Plugs (PG10267) to the bottom of the Base.

To avoid risk of personal injury never loosen clamp handle unless load on stand is supported. **WARNING!**

### SMK2 (Figure 21)

The SMK2 Backstop Kit is for use with the flat work table of your stitcher. The kit components can be assembled in various ways to fit specific applications. Choose the diagram which best fits your current needs and follow the instructions listed below.

Attach the Back Stop Clamp Blocks (MG10125) to the slots in your table by inserting the Carriage Bolts (PG10244) up through the slots in your work table and through the holes in the Clamp Block. Place the Lock Nuts (MG10105) on the ends of the Carriage Bolts. Slide the Back Stop Rod (MG10123) through the Clamp Blocks and Backstop Blocks (MG10124) as desired. Use the Nylon Stop Rod Screws (PG10243) to hold the Rod and Blocks in place.

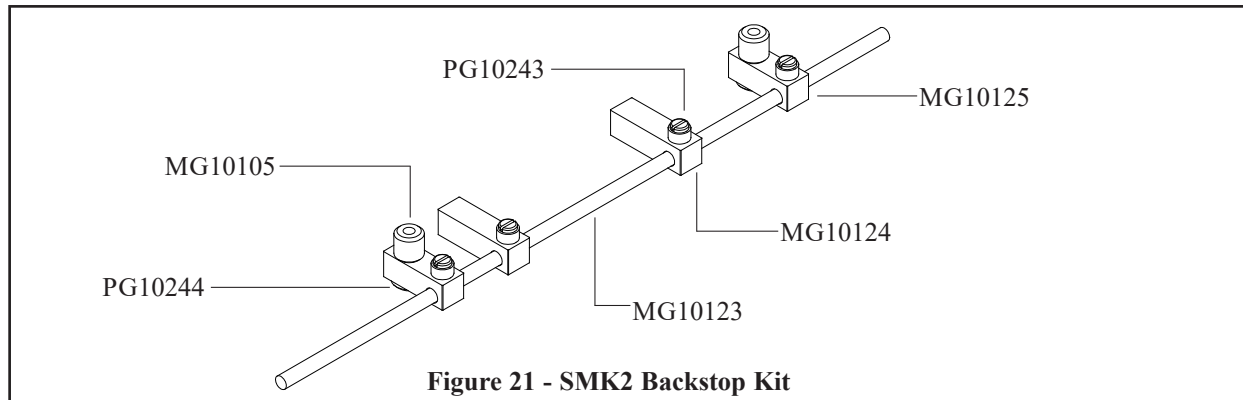

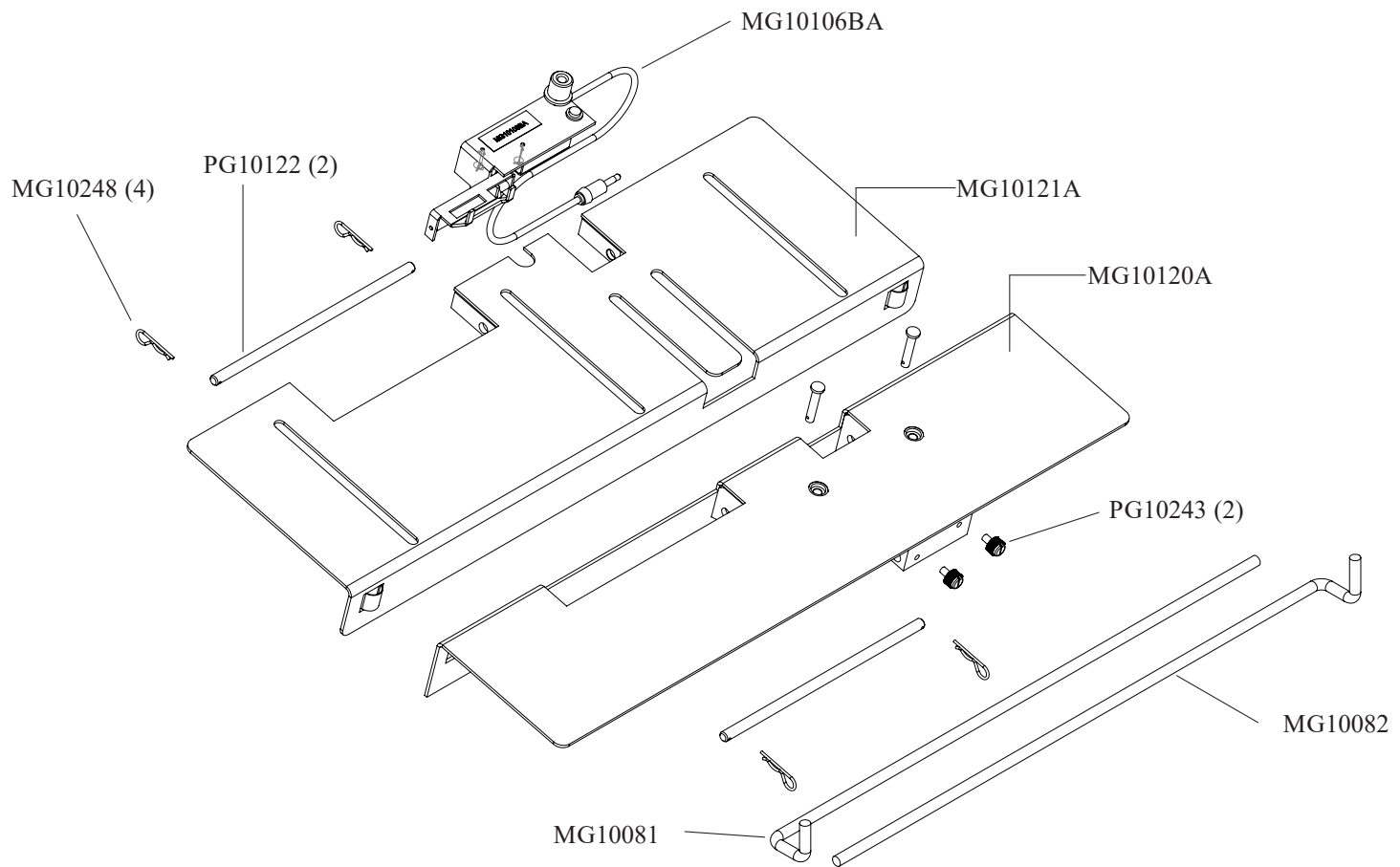

**SMK7 (Figure 22)**

**Figure 22 - Dual-Head Table Assembly**

*MG10121A	Rear Work Table Assembly	1
*MG10120A	Front Work Table Assembly	1
*PG10122	Table Pivot Rod	2
*PG10248	Pin, 1/4 Hitch	4
*PG10632A	Crossover Cable - Complete (Not Shown)	1
PG10242	Self Lock Pin 3/16x1	2
PG10243	Plastic-Head Thumb Screw	2
MG10081	Left Side Stop Rod	1
MG10082	Right Side Stop Rod	1
MG10106BA	Table Trip Assembly - SMHP	1

\* These parts are included in kit SMK7. See DBS1009B manual. The remaining parts in this list are originally included with the single head machine.

The SMK7 Dual-Head Kit is for use with two StitchMaster HP's mounted side-by-side on a work table or on an FSK1 Adjustable Floor Stand with a SMK4 Double Head Mounting Plate Assembly Kit, both sold separately.

Note: In order to use only one StitchMaster, simply turn the machine you choose not to use off and use the other machine as you would a single machine.

### **SMK4 (Figure 23)**

The SMK4 Dual-Head Mounting Plate Assembly Kit is for use with an FSK1 Adjustable Floor Stand and two StitchMaster HP's mounted side-by-side. To mount the Assembly, follow the instructions below.

Remove the StitchMaster HP from the Floor Stand, if it is already mounted. Remove the four (4) Screws (P2089) from the SMK4 Double Head Mounting Plate (MG10147). Place the Mounting Plate on top of the Stand and align the screw holes. The front of the Mounting Plate should be flush with the front of the Stand. Place the four screws through the holes, from the bottom and tighten with a wrench. Mount your StitchMaster HP's on the Mounting Plate, side-by-side.

**Do not tighten the Clamp on an uneven surface.**

**CAUTION!**

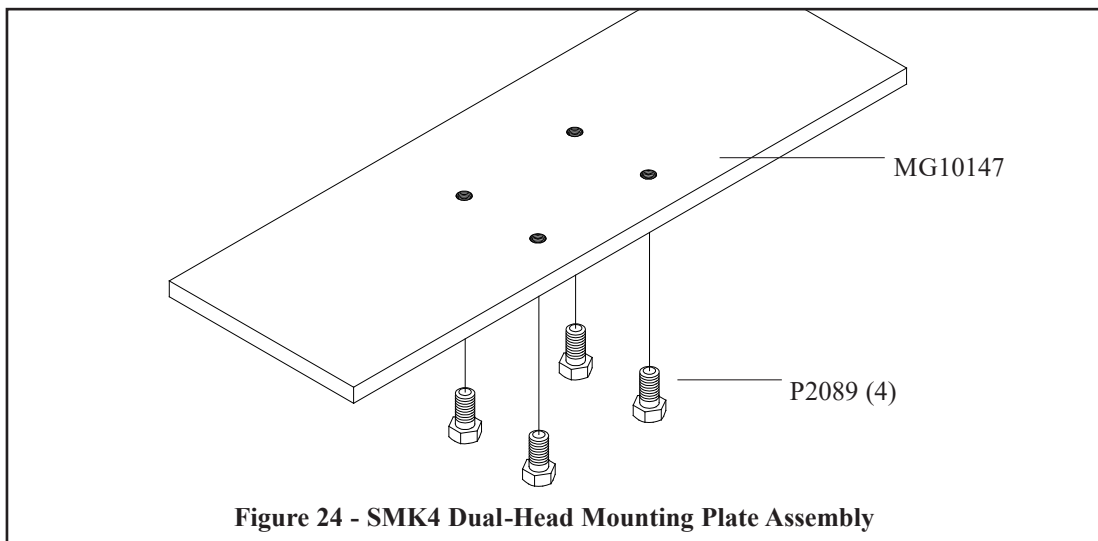

**Figure 24 - SMK4 Dual-Head Mounting Plate Assembly**

**Notes:**



# **LIMITED WARRANTY**

DeLuxe Stitcher Company, Inc. warrants to the original retail purchaser that this product is free from defects in material and workmanship and agrees to repair or replace, at DeLuxe Stitcher's option, any defective product within 90 days from the date of purchase. This warranty is not transferable. It covers damage resulting only from defects in material or workmanship and does not cover conditions or malfunctions resulting from normal wear, neglect, abuse or accident.

This warranty is in lieu of all other express warranties. Any warranty of merchantability or fitness for a particular purpose is limited to the duration of this warranty. DeLuxe Stitcher shall not be liable for any incidental or consequential damages.

Some states do not allow limitations on how long an implied warranty lasts, or the exclusion or limitation of incidental or consequential damages, so the above limitations or exclusions may not apply to you. This warranty gives you specific legal rights and you may also have other rights which vary from state to state.

To obtain warranty service you must return the product, at your expense, together with proof of purchase to an authorized DeLuxe Stitcher Company Graphic Arts Dealer.  
Always use genuine DeLuxe Stitcher parts.

When ordering parts, please identify the part number, the part name, the wire size and crown size of your Stitcher.



# REGISTRATION

To better service your wire stitching needs, please take a moment to fill out and return this registration card.

Name : \_\_\_\_\_  
( First ) ( Middle Initial ) ( Last )  
Company : \_\_\_\_\_  
Street Address : \_\_\_\_\_  
City : \_\_\_\_\_ State/Province : \_\_\_\_\_ Zip : \_\_\_\_\_  
Country : \_\_\_\_\_  
Phone : \_\_\_\_\_ Fax : \_\_\_\_\_ E-mail : \_\_\_\_\_

## CUSTOMER

Machine(s) Purchased : \_\_\_\_\_  
Serial Number(s) : \_\_\_\_\_  
With Head(s) : \_\_\_\_\_  
( Type/Quantity Purchased )  
Serial Number(s) : \_\_\_\_\_  
Head(s) Purchased : \_\_\_\_\_  
Serial Number(s) : \_\_\_\_\_

## PRODUCT

Date Received : \_\_\_\_\_  
Dealer Name : \_\_\_\_\_  
Dealer Street Address : \_\_\_\_\_  
City : \_\_\_\_\_ State/Province : \_\_\_\_\_ Zip : \_\_\_\_\_  
Country : \_\_\_\_\_  
Dealer Phone : \_\_\_\_\_

## DEALER

Other Bindery Products Used : \_\_\_\_\_

Please take a moment to fill out the attached card and mail it to DeLuxe Stitcher Company, Inc.. In addition, duplicate the information for your records to assist when making further inquiries.

### PRODUCT

Machine(s) Purchased : \_\_\_\_\_  
Serial Number(s) : \_\_\_\_\_  
With Head(s) : \_\_\_\_\_  
( Type/Quantity Purchased )  
Serial Number(s) : \_\_\_\_\_  
Head(s) Purchased : \_\_\_\_\_  
Serial Number(s) : \_\_\_\_\_

### DELUXE STITCHER GRAPHIC ARTS REPRESENTATIVE

Date Received : \_\_\_\_\_  
Dealer Name : \_\_\_\_\_  
Dealer Street Address : \_\_\_\_\_  
City : \_\_\_\_\_ State/Province : \_\_\_\_\_ Zip : \_\_\_\_\_  
Country : \_\_\_\_\_  
Dealer Phone : \_\_\_\_\_

Would you like information sent to you about new products that would benefit your company?  Yes  No

## Common Replacement

Below is a list of the most common wear/replacement parts for the StitchMaster HP. This guide should help you when ordering replacement parts. If the part you need is not listed below, please refer to the more detailed parts list on pages 38-48 in this manual.

Description	Item Number
Clincher Points	CA9083A
Driver	CA9009
Grip	CA9015
Grip Retaining Clip	CA9023
Grip Retaining Screw	9024
Bender Bar Latch	CA9014
Grip Spring	CA9019B
Grip Spring Retaining Screw	9020
Swivel Operating Spring	9046A
Swivel	CAA9038M
Wire Cutter	9048
Motor Brush Assembly	PG10289
Driver Bar	9012A
Clincher Plate	9800A
Supporter - 1/2"	9026A

**PLACE  
STAMP  
HERE**

**DELUXE STITCHER**  
**COMPANY, INC.**  
 3747 N. Acorn Lane  
 Franklin Park, IL 60131.  
 Attn: Customer Service





3747 Acorn Lane • Franklin Park • Illinois 60131

Phone: 847-455-4400 • 800-634-0810

Fax: 847-455-4900 • 800-417-9251

<http://www.deluxestitcher.com>

**DBSSMHP 0723**