

DeLuxe StITCHER

COMPANY INC.

solving your wire stitching needs for 125 years...

ISP Stitching & Bindery Products

MODEL P MANUAL

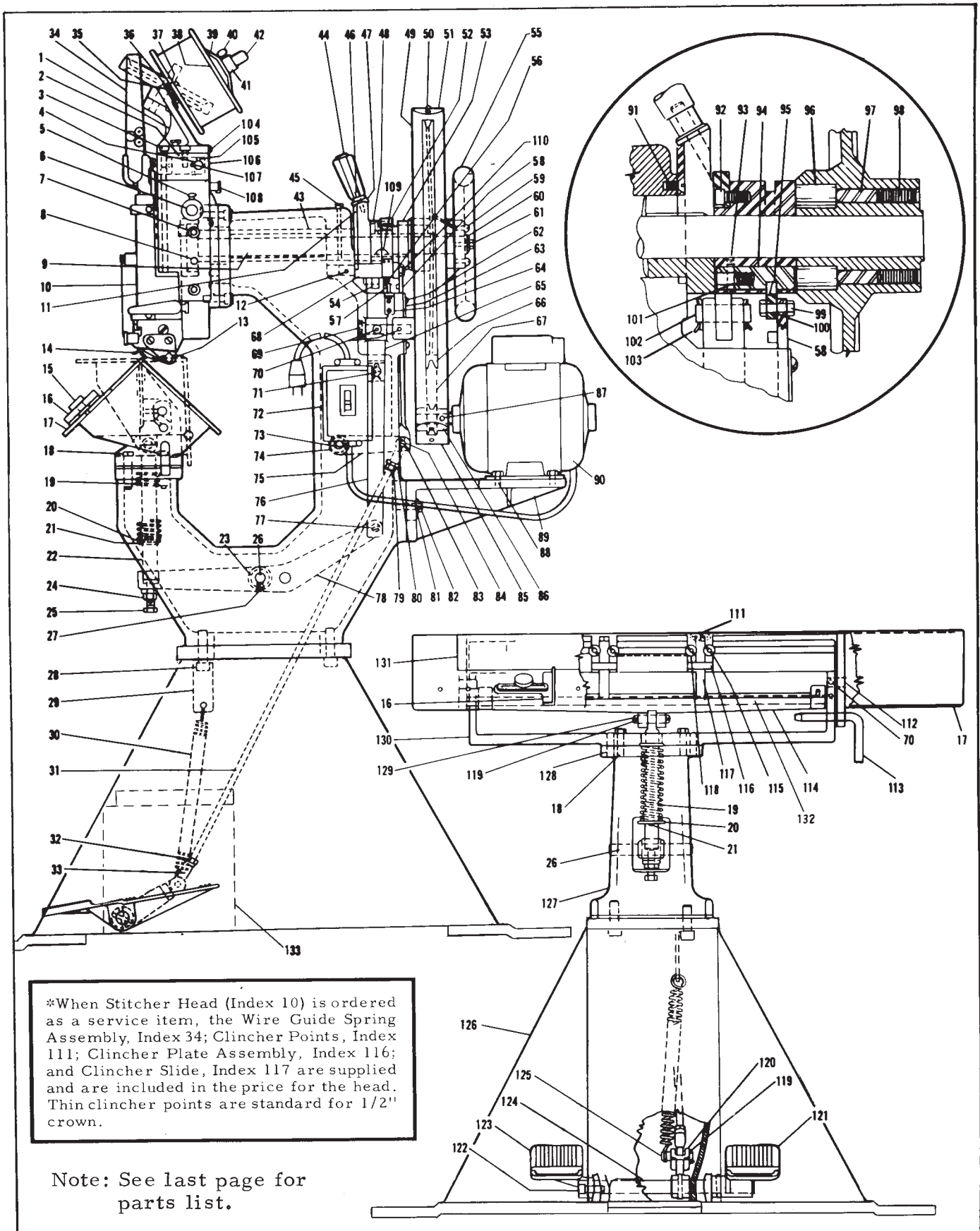

*When Stitcher Head (Index 10) is ordered as a service item, the Wire Guide Spring Assembly, Index 34; Clincher Points, Index 111; Clincher Plate Assembly, Index 116; and Clincher Slide, Index 117 are supplied and are included in the price for the head. Thin clincher points are standard for 1/2" crown.

Note: See last page for parts list.

**Model P Stitching Machine
Drive Assembly**

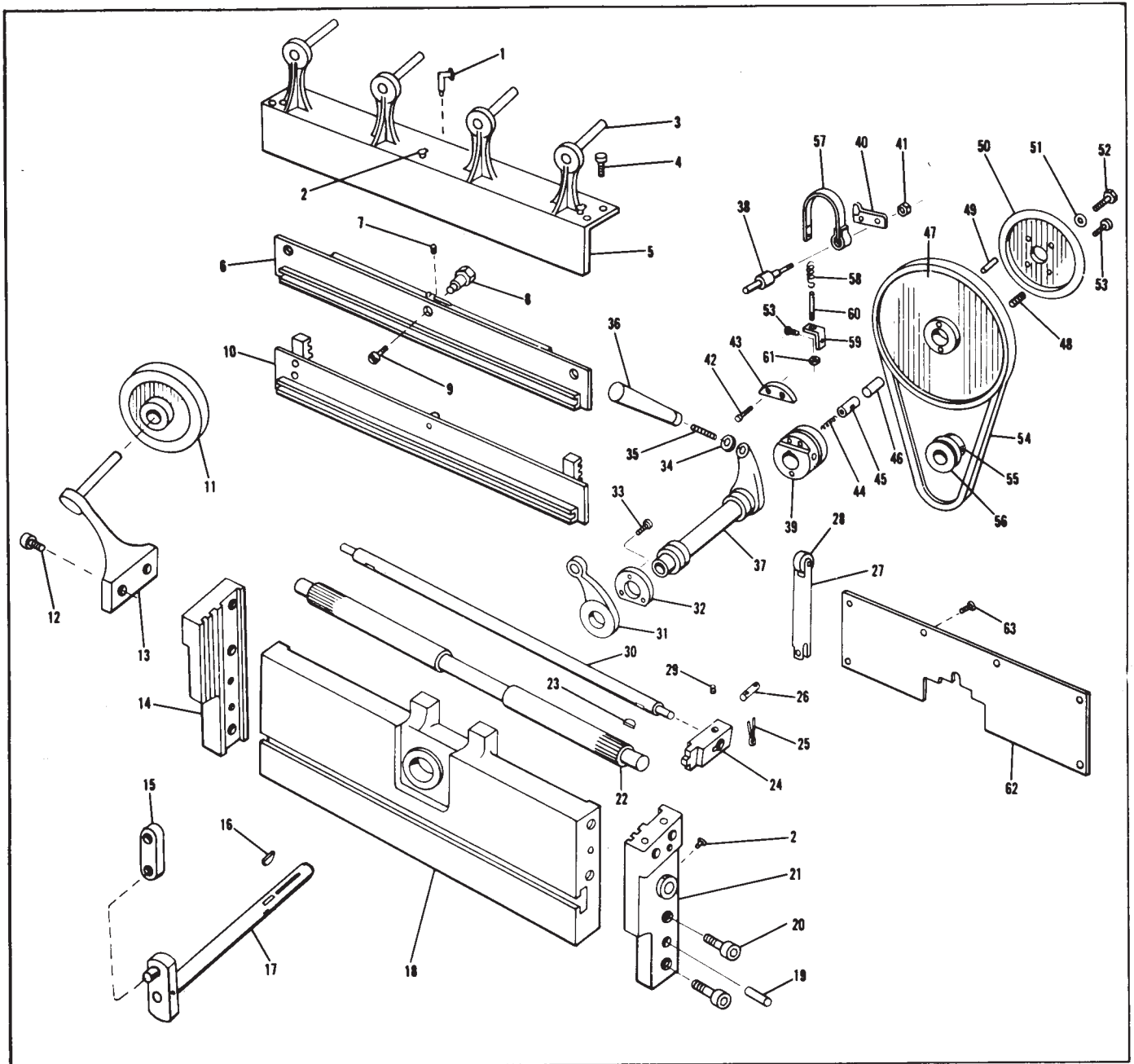

CHAMPION MODEL "P" STITCHER

Eccentric adjusting sleeve Index 37 controls the amount of wire feed also the starting and stopping position of the bender bar assembly in the stitcher head.

When the handle Index 36 is moved to the extreme left, the eccentric adjusting sleeve moves wire feed slide rack Index 6 downward for minimum wire feed. It also will move the starting and stopping position of the driving slide plate Index 10 to the lowest point for minimum work thickness. (The amount of stroke isn't changed. It remains at 2". The eccentric merely moves the complete stroke up or down depending on the thickness of work to

be stitched.)

Moving handle Index 36 to right or left rotates eccentric sleeve Index 37. Wire draw adjusting lever link Index 31 and the crank and shaft Index 17 is moved up or down by the eccentric sleeve. Wire feed slide rack Index 6 is connected to the wire draw adjusting lever link with stud Index 8. Therefore, when the eccentric sleeve moves the wire draw adjusting lever Index 31, it also moves the wire feed slide rack up or down. Driving slide plate Index 10 is connected to the cam and shaft Index 17 with drive link Index 15. The eccentric sleeve raises or lowers the crank and shaft. Therefore, the stroke required to drive the stitching is moved either up or down.

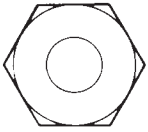

PARTS LIST

Model P Stitching Machine

Drive Assemblies

Index Number	Part Number	Part Name	Index Number	Part Number	Part Name
1	CB-45-C	90° Oil Cup	27	CE-23	Clincher Cam Rod
2	CB-45	Oil Cup	28	CE-25	Clincher Cam Roller
3	CA-45	Spool Stud	29	CB-722	Socket Set Screw, #10-32x3/8"
4	CB-77-A	Socket Hd. Cap Screw, 1/4"-20x5/8"	30	CE-55	Leveler Link Shaft
5	CE-45	Spool Holder Bracket	31	CE-56	Wire Draw Adj. Lifter Link
6	CEE-50	Wire Feed Slide Plate Assy.	32	CE-63	Eccentric Lock Plate
	CE-50	Wire Feed Slide Plate	33	CB-352	Flat Hd. Mach. Screw #10-32x1/2"
	CE-51	Wire Feed Slide Rack	34	CA-92	Eccentric Handle Washer
	CE-52	Wire Feed Spacer Block	35	CA-91	Eccentric Handle Stud
7	CB-141	Socket Hd. Set Screw, 1/4"-20x1/4"	36	CE-89	Eccentric Handle
8	CE-53	Wire Draw Eccentric	37	CE-62	Eccentric Adj. Sleeve
9	CB-132	Flat Hd. Mach. Screw, 1/4"-20x5/8"	38	CE-66	Clutch Plate Pivot Stud
10	CEE-46	Driving Slide Plate Assy.	39	CE-64	Clutch Hub
	CE-46	Driving Slide Plate	40	CE-97	Clutch Plate
	CE-47	Driving Slide Rack	41	CB-418	Hex. Nut, 5/16"-24 N.F. Full
	CE-48	Driving Slide Plate Stud	42	CE-101	Socket Hd. Cap Screw, 1/4"-28x1/2"
	CE-109	Gear Rack	43	CE-65	Clincher Cam
	CT-36	Dowel Pin, 5/32"x5/8"	44	CB-128	Clutch Pin Spring
	CE-96	Ctrsk. Hd. Rivet, 5/32"x1"	45	CB-130	Clutch Pin
	CB-132	Flat Hd. Mach. Screw, 1/4"-20x5/8"	46	CB-131	Pulley Drive Pin
	CE-95	Washer	47	CBB-20-A	Flywheel and Drive Assy.
11	CT-12	Sheave, 6 Groove	48	CB-428	Socket Set Screw
	CT-12-A	Sheave, 8 Groove	49	CB-94	Drive Wheel Dowel Pin
12	CB-325	Socket Hd. Screw, 1/4"-20x1/2"	50	CB-270	Hand Wheel
13	CTT-11	Sheave Bracket Assy.	51	CB-34-A	Drive Shaft Washer
14	CE-44	Left Side Plate	52	CB-35-A	Hex. Hd. Cap Screw, 5/16"-18x5/8"
15	CT-30-A	Driver Link	53	CB-126	Rd. Hd. Mach. Screw, #10-32x3/8"
16	CB-286	Woodruff Key	54	CE-127	V-Belt
17	CEE-58	Crank and Shaft Assy.	55	CB-177	Socket Set Screw, 5/16"-18x3/4"
18	CE-42	Main Face Plate	56	CB-176-B	Motor Pulley
19	CB-313	Dowel Pin, 5/16"x1 1/4"	57	CEE-67	Brake Strap Assy.
20	CB-314	Socket Hd. Cap Screw, 3/8"-16x1"	58	CE-70	Brake Spring
21	CE-43	Right Side Plate	59	CE-72	Brake Spring Anchor
22	CE-49	Gear Shaft	60	CE-71	Brake Screw
23	CE-75	Woodruff Key, #5	61	CB-278	Hex. Nut, #10-32
24	CE-54	Leveler Link	62	CE-57	Rear Cover Plate
25	CB-168	Cotter Pin, 3/32"x3/4"	63	CB-258	Rd. Hd. Mach. Screw, #8-32x1/4"
26	CE-24	Clincher Link Pin			

Auxiliary Spool Bracket Assembly

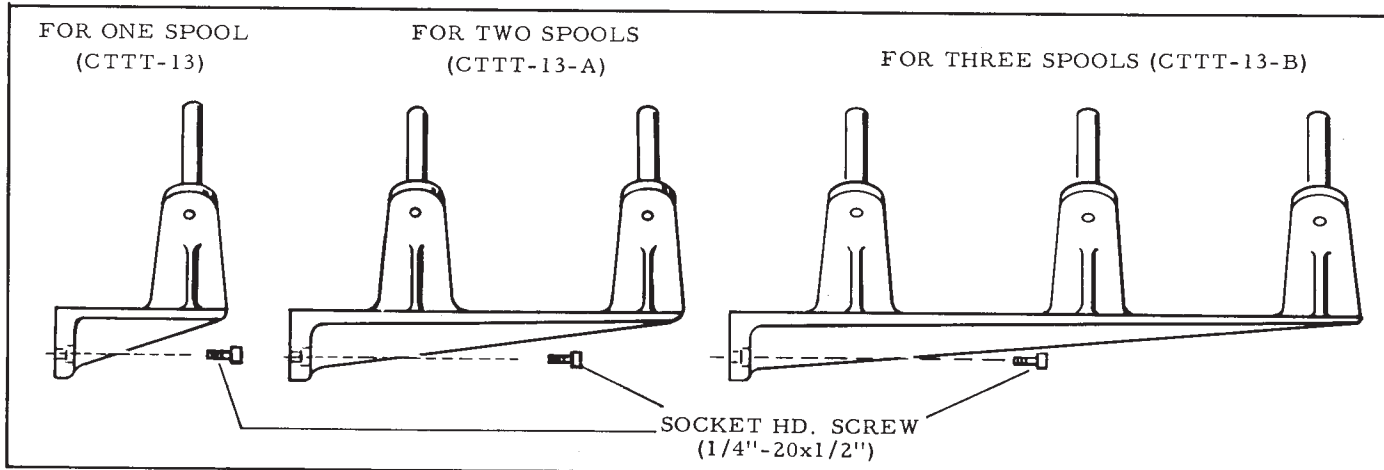

Index Number	Part Number	Part Name	Index Number	Part Number	Part Name
1	CE-45	Spool Holder Bracket	70	CB-138	Socket Set Screw
2	CE-54	Leveler Link	71	CE-24	Clincher Link Pin
3	CB-77-A	Socket Hd. Cap Screw	72	CBB-285	Motor Switch Assy. (With Cord & Plug)
4	CE-55	Leveler Link Shaft	73	CE-30	Clutch Lever Shaft
5	CB-45	Oil Cup	74	CE-31	Clutch Lever Collar
6	CE-49	Gear Shaft	75	CE-28	Upper Clutch Rod Lever
7	CB-314	Socket Hd. Cap Screw	76	CE-21	Clincher Drive Link
8	CB-313	Dowel Pin	77	CE-22	Clincher Crank Connecting Pin
9	CEE-58	Crank and Drive Shaft Assy.	78	CE-19	Clincher Operating Lever
10	CTTT-2601-C	Stitcher Head	79	CE-77	Rod End Lock Nut
	CTTT-2133-A	Wire Guide	80	CE-37	3/8" Rod End
	CTT-9086	Clincher Plate Assy.	81	CB-179	Washer
11	CE-63	Eccentric Lock Plate	82	CB-375	Hex. Hd. Cap Screw
12	CB-59	Socket Set Screw	83	CB-168	Cotter Pin
13	CE-90	Back Gauge	84	CE-33	Clutch Rod Pin (Upper)
14	CEE-104	Work Alignment Gauge	85	CB-275	Pulley Guard Plate (Bottom)
15	CA-55	Gauge Hold-Down Screw	86	CB-176-A	Motor Pulley
16	CB-576	Side Gauge	87	CB-177	Motor Pulley Set Screw
17	CEEE-3	Saddle Assy. (Less Gauges)	88	CB-35-A	Hex. Hd. Cap Screw
18	CB-375	Hex. Hd. Cap Screw	89	CA-6	Motor Bracket
19	CE-16	Clincher Spring	90	CB-173-M	Motor 1/3 H.P.
20	CE-17	Washer	91	CB-352	Flat Hd. Mach. Screw
21	CE-18	Cotter Pin	92	CE-101	Socket Hd. Cap Screw
22	CE-14	Front Clincher Drive Rod	93	CB-127	Clutch Pin Guide Screw
23	CE-26	Spacer	94	CB-130	Clutch Pin
24	CE-98	Clincher Adjustment Screw Lock Nut	95	CE-97	Clutch Plate
25	CE-76	Clincher Adjustment Screw	96	CB-131	Drive Pin
26	CE-20	Clincher Crank Shaft	97	CB-94	Pin
27	CB-377	Socket Set Screw	98	CB-428	Socket Set Screw
28	CB-689	Socket Hd. Cap Screw	99	CB-278	Hex. Nut
29	CE-40	Spring Anchor	100	CE-34	Clutch Plate Shoulder Screw
30	CE-39	Foot Treadle Tension Spring	101	CB-128	Clutch Spring
31	CE-36	Clutch Rod	102	CE-24	Clincher Link Pin
32	CE-77	Rod End Adjustment Lock Nut	103	CB-168	Cotter Pin
33	CE-37	3/8" Rod End	104	CB-258	Round Hd. Screw
34	CTTT-2133-A	Wire Guide Spring Assy.	105	CB-722	Socket Hd. Set Screw
35	CA-46	Thrust Bearing Washer (Small Hole)	106	CE-57	Rear Guard Plate
36	CA-114	Thrust Bearing	107	CE-75	Woodruff Key
37	CA-113	Thrust Bearing Washer (Large Hole)	108	CB-45-C	90° Oil Cup
38	CBBB-22	5 Lb. Spool Assy.	109	CB-286	Woodruff Key
39	CB-221	Coil Holder Friction Spring	110	CB-418	Hex. Hd. Nut (Full)
40	CA-54	Thumb Screw	111	CA-9083	Clincher Points
41	CA-95	Coil Holder Stud Collar	112	CE-13	Saddle Shaft Pivot
42	CA-45	Coil Holder Stud	113	CA-57	Saddle Lock Pin
43	CE-62	Eccentric Adjustment Sleeve	114	CE-10	Clincher Slide Lift Lever
44	CE-89	Eccentric Sleeve Adjustment Handle	115	CT-9088	Clincher Plate Binder Bolt
45	CB-45	Oil Cup	116	CTT-9086	Clincher Plate Assy.
46	CA-91	Eccentric Sleeve Handle Screw	117	CT-9093	Clincher Slide
47	CA-92	Eccentric Sleeve Handle Washer	118	CA-2091	Clincher Plate Binder Nut
48	CE-65	Clincher Cam	119	CB-168	Cotter Pin
49	CEEE-73	Pulley Guard Assy. (Complete)	120	CE-29	Clutch Rod Lever
50	CB-258	Pulley Guard Connecting Plate Screw	121	CA-7	Foot Pedal (Right)
51	CB-274	Pulley Guard Connecting Plate (Top)	122	CB-110	Socket Hd. Cap Screw
52	CEE-67	Brake Strap Assy.	123	CA-8	Foot Pedal (Left)
53	CE-64	Clutch Hub	124	CE-41	Foot Treadle Shaft
54	CE-25	Clincher Cam Roll	125	CE-38	Clutch Rod Pin (Lower)
55	CB-270	Hand Wheel	126	CA-1-A	Base
56	CE-70	Brake Spring	127	CE-2	Top Frame
57	CE-71	Brake Screw	128	CB-313-A	Dowel Pin
58	CEE-27	Clutch Throwout Rod Assy.	129	CE-15	Clincher Block Pivot Pin
59	CB-126	Screw	130	CE-9	Clincher Support
60	CB-34-A	Washer	131	CEE-5	Top Plate Assy.
61	CB-35-A	Hex: Hd. Cap Screw		CE-5	Top Plate
62	CB-126	Screw		CE-91	Spring Clip
63	CE-35	Clutch Rod Retaining Plate		CE-92	Round Hd. Rivet
64	CE-72	Brake Spring Screw Anchor		CE-93	Reinforcing Bar
65	CE-23	Clincher Cam Rod		CB-614	C.S. Hd. Rivet
66	CBB-20-A	Main Drive Wheel		CE-12	Shaft
67	CA-79	V-Belt	132		
68	CE-66	Clutch Plate Shaft	133	CA-134	Foot Pedal Guard
69	CA-62	Pulley Guard Stud			

 **DELUXE STITCHER**
COMPANY INC.
ISP Stitching & Bindery Products