

# STITCHER HEADS

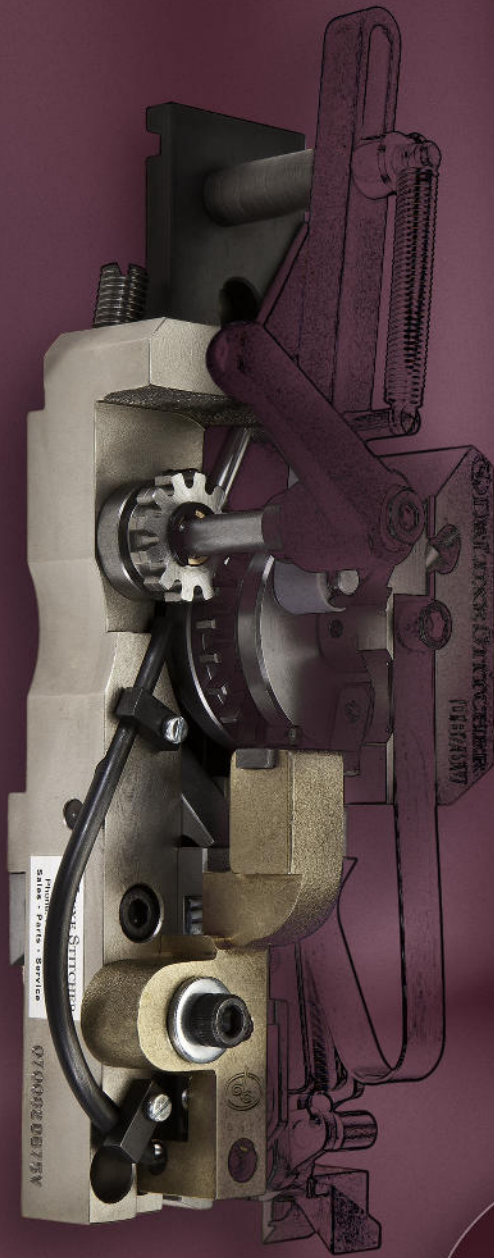

# DeLuxe STITCHER

COMPANY INC.

SOLVING YOUR WIRE STITCHING NEEDS FOR 125 YEARS

# DB STITCHER HEADS

## PERFORMANCE HEADS

The DB line of Stitchers is designed to meet the needs of Muller Martini® users. These heads are highly durable and feature parts that are fully interchangeable with original equipment.

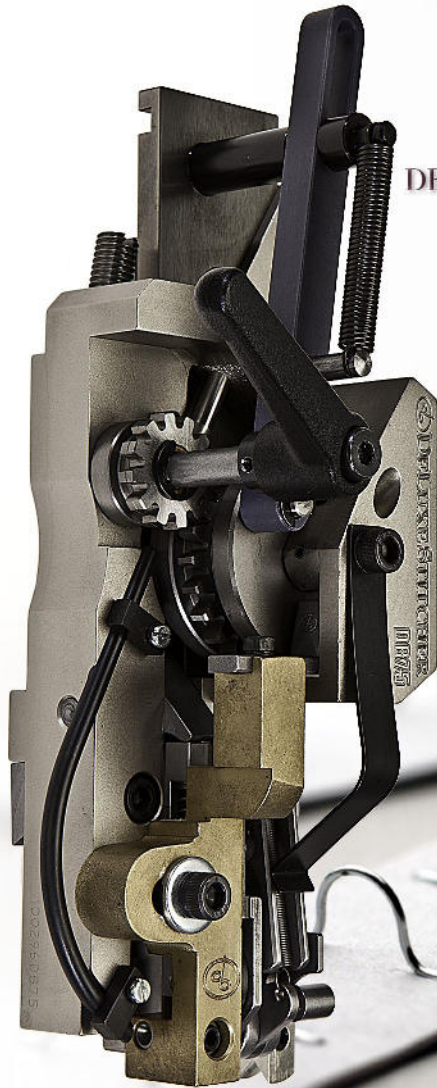

DB-75



DB-75V



DB-45

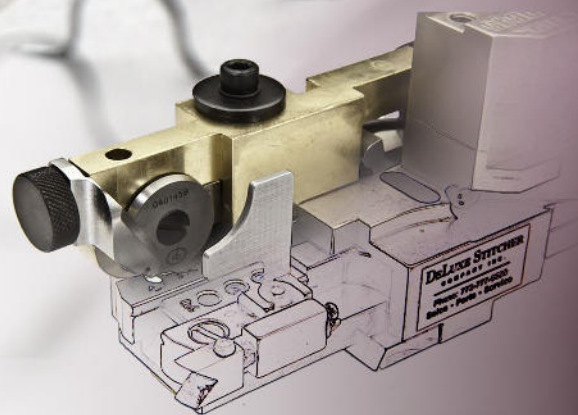

[WWW.DELUXESTITCHER.COM](http://WWW.DELUXESTITCHER.COM)

# SIDE FEED STITCHER HEADS

## ELIMINATE WIRE JAMMING AND DROPPED STITCHES

Deluxe's wide range of side feed heads gives you many choices for your saddlestitching needs. From the ultra narrow G5 to the versatile G8 to the heavy duty G20, we are sure to have the right solution.



G8

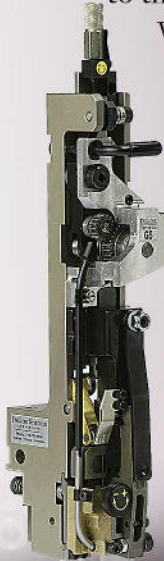

G5



G20

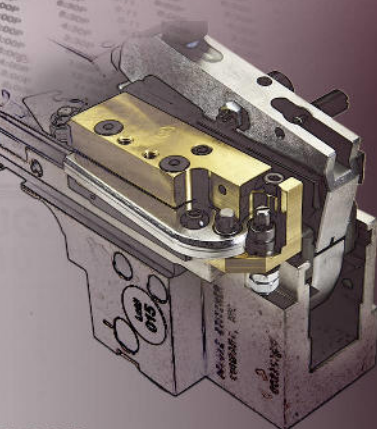
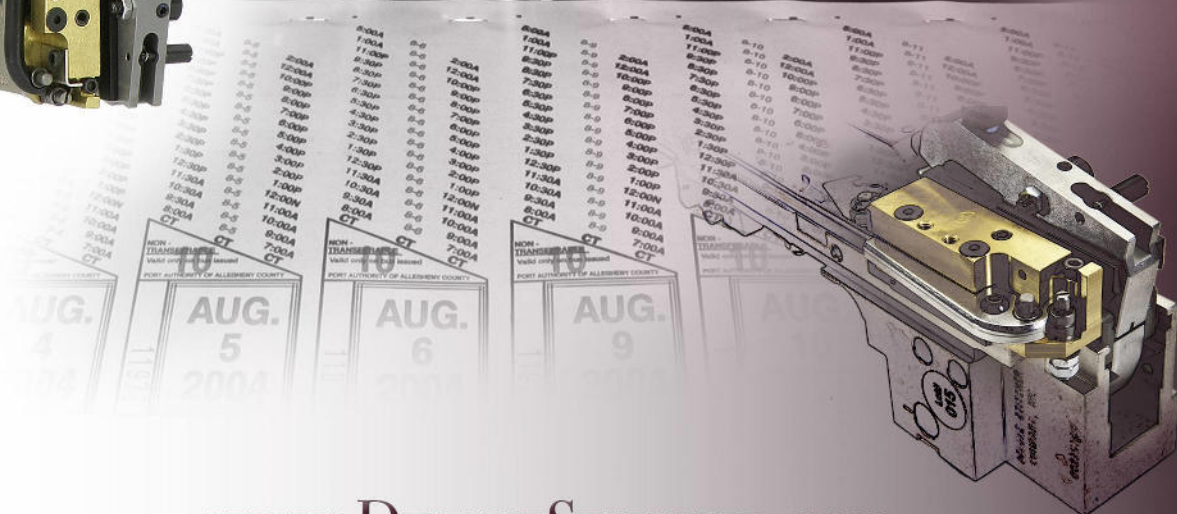
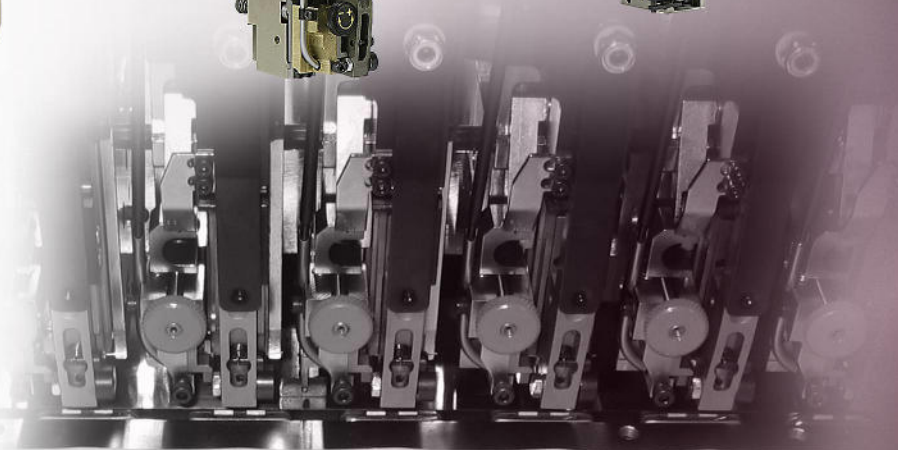

[WWW.DELUXESTITCHER.COM](http://WWW.DELUXESTITCHER.COM)

# SWIVEL STITCHER HEADS

## TRADITIONAL HEADS

For over 90 years, Deluxe has been manufacturing swivel style heads. The 18D & 26D heads have remained one of the most versatile heads on the market, now with the addition of ISP's M2000 Deluxe's extensive product range is sure to meet your needs.

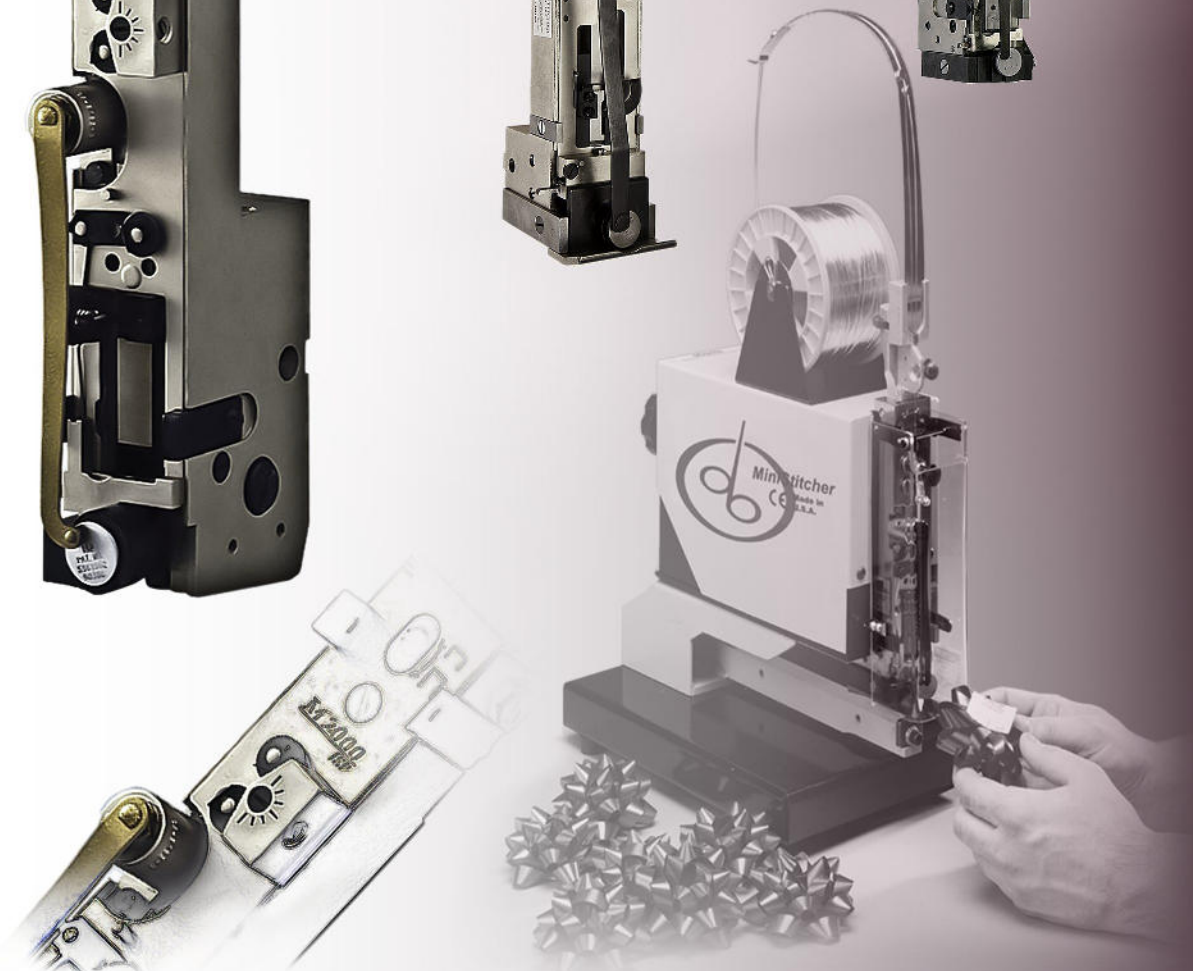
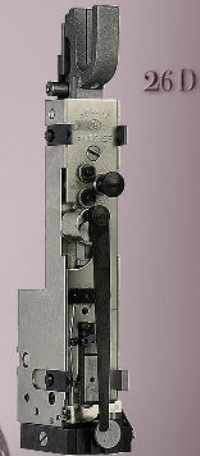

[WWW.DELUXESTITCHER.COM](http://WWW.DELUXESTITCHER.COM)

# OSAKO® HEADS

## SIMPLICITY AND DEPENDABILITY

Since 2005, Deluxe Stitcher has partnered with Osako® & Co. to produce stitching heads for new saddle stitchers. Together our blend of worldwide dealership networks will make getting the right Osako® stitcher head or spare part easier than ever.

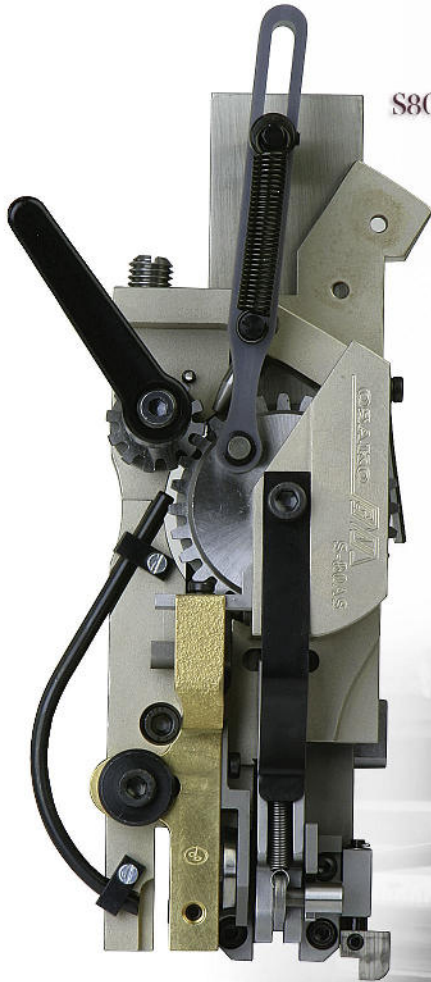

S80AS



S50



S80A

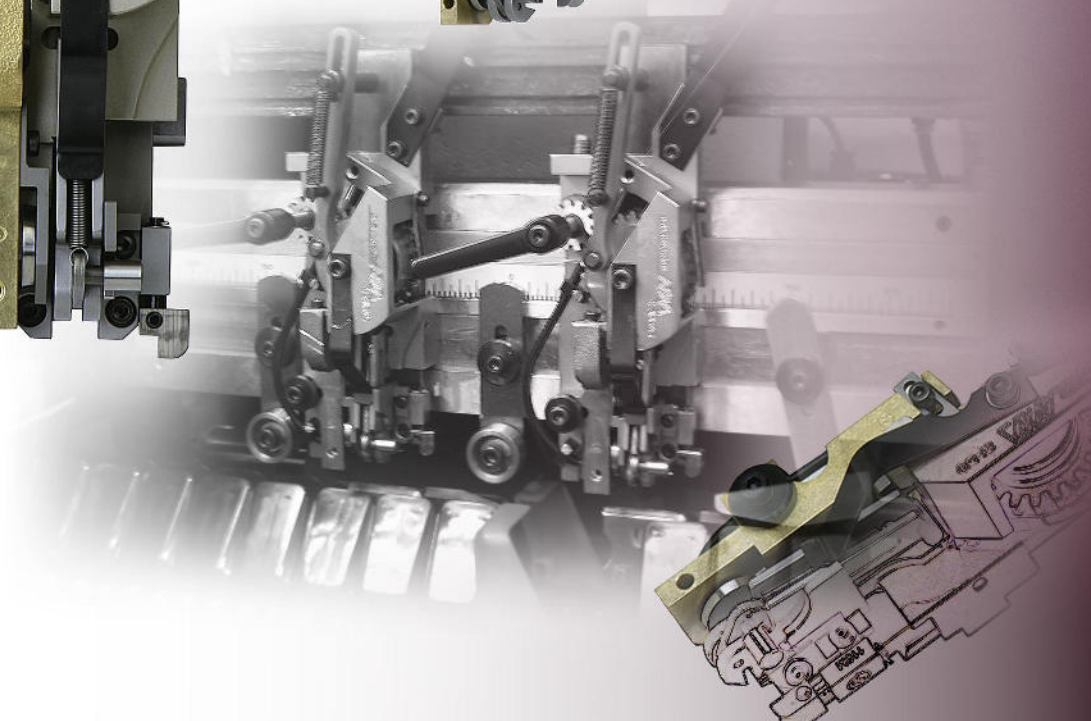

[WWW.DELUXESTITCHER.COM](http://WWW.DELUXESTITCHER.COM)

# TECHNICAL INFORMATION

	<b>G5</b>	<b>G8</b>	<b>G20</b>	<b>26/26D &amp; M2000</b>	<b>18D</b>	<b>DB Style DB45</b>	<b>DB Style DB75 Series</b>	<b>Osako Style S50</b>	<b>Osako Style S80</b>
<b>Capacity</b> May vary depending on material type & wire quality. Sheet count is based on 20 lb (75 gsm) paper	2 sheets to 3/16" [5 mm] Approx. 45 sheets	2 sheets to 5/16" [8 mm] Approx. 75 sheets	2 sheets to 3/4" [20 mm] Approx. 170 sheets	2 sheets to 1/4" [6 mm] Approx. 55 sheets	2 sheets to 9/16" [14mm] Approx. 130 sheets	2 sheets to 1/8" [3 mm] Approx. 25 sheets	DB75: 2 sheets to 3/16" [5 mm] 45 sheets  DB75V & 75VS 2 sheets to 1/4" [6 mm] 55 sheets  DB75V Loop: 1/8" [3mm] 25 sheets	2 sheets to 1/8" [3 mm] Approx. 25 sheets	2 sheets to 3/16" [5mm] Approx. 45 sheets
<b>Crown Size(s)</b> Standard crown size is shown in <b>bold</b> .	<b>1/2" [13 mm]</b>  13/64" [5 mm] Loop	<b>1/2" [13 mm]</b>  13/64" [5 mm] Loop	<b>1/2" [13 mm]</b>  5/8" [16 mm], 13/64" [5 mm] Loop	<b>1/2" [13 mm]</b>  5/16" [8 mm], 3/8" [10 mm], 5/8" [16 mm]	<b>1/2" [13 mm]</b>  3/8" [10 mm], 5/8" [16 mm], 3/4" [20 mm]	<b>7/16" [10 mm]</b>	<b>1/2" [13 mm]</b>  DB75V Loop: 3/16" [5 mm]	<b>1/2" [13 mm]</b>	<b>1/2" [13 mm]</b>
<b>Wire Size(s)</b> Non-standard wire size may require optional accessories.	25-28 gauge round 21x25 flat 25 gauge round wire is standard	23-28 gauge round, 20x24, 21x25 flat, 24 gauge round wire is standard	20-28 gauge round, 19x211/2, 20x24, 20x25, 21x25 flat 24 gauge round or 20x24 flat are standard	21-28 gauge round, 21x25 flat 25 gauge wire is standard	20-28 gauge round, 19x211/2, 20x24, 20x25, 21x25 flat, Hybar I & II .103 x .020 ribbon (25 gauge round or 20x24 flat are standard)	25-28 gauge round	20-28 gauge round, 20x24, 21x25 flat  DB75V Loop: 25 gauge round wire	25-28 gauge round	25-28 gauge round
<b>Minimum Head Centers</b> Machine may limit center to center distance	1-1/2" [39 mm] up to 1/32" [1 mm] material thickness	2-3/64" [52 mm] at two sheets up to 1/16" [1.5mm] material thickness	2-3/4" [70 mm] at two sheets up to 1/16" [1.5mm] material thickness	1-7/8" [48 mm] for all material thickness	3" [75 mm] for all material thickness Optional 2-3/4" version available	1-3/4" [45 mm] up to 1/16" [1.5mm] material thickness	3" [75 mm] up to 1/16" [1.5 mm] material thickness	2" [50 mm] up to 1/16" [1.5 mm] material thickness	3-1/8" [80 mm] up to 1/16" [1.5 mm] material thickness
<b>Stitch Speed</b> Sph=Stitches per hour Effective speed of machine capacity is highly dependant on operator.	Maximum 10,000 sph	Maximum 20,000 sph: 12,000 sph with Loop heads	Maximum 18,000 sph 12,000 sph with Loop heads	Maximum 12,000 sph	Maximum 16,000 sph	Maximum 12,000 sph	DB75 & DB75V: Max. 15,000 sph  DB75VS: Max. 20,000 sph  DB75V Loop Max. 10,000 sph	Maximum 12,000 sph	Maximum 15,000 sph
<b>Common Machine Uses</b>	C.P. Bourg, Duplo, Harris, Heidelberg, Horizon, Macey, McCain, Panduro, Plockmatic, Rosback, Stahl, Theisen & Bonitz, Watkiss And others	C.P. Bourg, Duplo, Harris, Heidelberg, Horizon, Macey, McCain, Plockmatic, Rosback, Stahl, Theisen & Bonitz and others.	AM Graphics, Bielomatik, Christensen, ECH Will, Goss, Harris, Heidelberg, Kugler, McCain, Sheridan and others.	C.P Bourg, Duplo, Harris, Heidelberg, Horizon, Macey, McCain, Plockmatic, Rosback, Stahl, Theisen & Bonitz, Watkiss and others.	AM Graphics, Bielomatik, Christensen, ECH Will, Goss, Harris, Heidelberg, Kugler, McCain, Sheridan and others.	Müller-Martini, Purlux and Sankoh	Müller-Martini, Purlux and Sankoh	OSAKO	OSAKO

3747 N Acorn Lane  
Franklin Park, IL 60131 - USA  
T: 847-455-4400 F: 847-455-4900

[WWW.DELUXESTITCHER.COM](http://WWW.DELUXESTITCHER.COM)