

DELUXE STITCHER

COMPANY INC.

solving your wire stitching needs for 125 years...

Head Serial Number : _____

Date Purchased : _____

Where Installed: _____

(make/model of machine)

MAGNATEK

OPERATION AND MAINTENANCE MANUAL

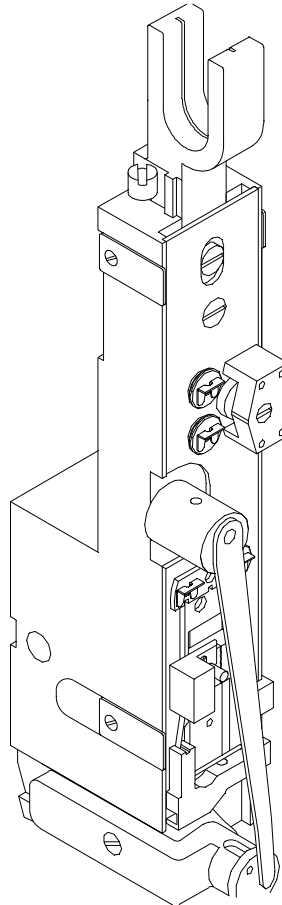

Before using this Stitcher Head, all operators must study this manual and follow the safety warnings and instructions. Keep these instructions with the MAGNATEK Stitcher Head for future reference. If you have any questions, contact your local DeLuxe Stitcher Company Graphic Arts Representative or Distributor.

CONTENTS

Section 1 **INTRODUCTION**

3. Model and Serial Number
3. Product Specifications

Section 2 **SAFETY PRECAUTIONS AND PROCEDURES**

4. Safety
4. Safety Guards/Cover

Section 3 **ASSEMBLIES, LUBRICATION, INSTALLATION**

5. Before Unpacking
5. After Unpacking
5. Assembly
5. Threading wire and adjusting wire straighteners
6. Lubrication

Section 4 **OPERATION**

7. General Stitching
7. Changing Work Thickness

Section 5 **MAINTENANCE, TROUBLE SHOOTING AND ADJUSTMENT**

8. General
8. Recommended Spare Parts
8. Cleaning and oiling
8. Stitching Adjustments
8. To Equalize Both Legs of Stitch
9. Trouble Shooting-MAGNATEK Head
12. Insufficient or Excessive Compression
12. Clincher
13. Head/Clincher Alignment
13. Bender bar
14. Bender bar Friction Plug
14. Driver Bar
15. Driver
15. Bender Bar Latch
15. Grip, Grip Release Slide and Faceplate
16. Wire Cutters
17. Wire cutter Operating Slide
17. Proper Wire
17. Rotator
18. Wire Straighteners
19. Supporter
19. Tension Pawl
20. Dismantling Magnatek Head

Section 6 **PART LIST**

22. MAGNATEK Head Stitcher
28. Registration Form

**USE ONLY REPLACEMENT PARTS
DESIGNED AND MANUFACTURED
BY
DeLuxe Stitcher / ISP
SPECIFICALLY FOR YOUR
MAGNATEK STITCHER**

Section 1

INTRODUCTION

Here are the instructions on how to install, operate, maintain and make repairs on your...

MAGNATEK STITCHER HEAD

Stitcher Head Serial Number _____ Stitcher Head Wire Size _____

Stitcher Head Part Number _____

Stitcher Head Crown Width _____

When ordering parts or requesting information, please state:

***Stitcher Head Serial Number,
Stitcher Head Part Number,
Model,
Wire Size,
Crown Width
Part Number
Part Name
Quantity Required***

The Magnatek Stitching Head has been engineered and developed to provide you with the finest equipment available for your stitching needs. With proper care and maintenance it will give you years of satisfactory, efficient service. This manual shows you how to get top performance from your stitcher and is divided into 7 major sections.

Read the Magnatek Manual thoroughly. Study it carefully. Best stitching performance will be assured, if all the adjustments are made as instructed.

PRODUCT SPECIFICATIONS

Unit Weight:	Lbs.		
	4.5 lbs.		
Unit Envelope Size:	Height	Length	Width
Magnatek Head Without Wire Guide:	11 in.	3.12 in.	1.82 in.

Section 2

SAFETY PRECAUTIONS AND PROCEDURES

SAFETY

1. Make sure electrical power is turned off before performing any adjustment or maintenance.
2. Keep hand, tools, hair, and clothing clear of stitching area.
3. Become familiar with the moving components of your machine. Keep fingers away from areas that could pinch or cut.
4. Wear adequate safety equipment for eye and face protection. Observe your plant safety rules.
5. Practice “good housekeeping” in your work area. Keep it as clean and uncluttered as possible.
6. A well maintained machine is a safer machine. Clean and lubricate the machine at regular intervals. Check machine daily for broken or worn parts. Replace as necessary. DO NOT attempt to operate the machine if a part is broken.
7. Route all electrical cables away from pedestrian transportation lanes.
8. Make sure adequate safety guards and covers are in place. If you are unsure how to safely operate or maintain your Stitcher, contact your Service Representative.

DANGER

**KEEP HANDS CLEAR OF
STITCHING AREA**

CAUTION

**FOR YOUR SAFETY, MAKE
SURE ALL COVERS ARE
PROPERLY IN PLACE BEFORE
OPERATING MACHINE**

Section 3

ASSEMBLY, LUBRICATION INSTALLATION

Note:

These instructions must be followed to insure proper installation, efficient operation and the prevention of serious damage to your stitcher.

Before Unpacking:

Examine the outside of the crate or carton for any visible damage. If damaged DO NOT UNPACK THE STITCHER. Notify the carrier who delivered the stitcher.

After Unpacking:

Examine your stitcher carefully for any damage in transit. If damaged, DO NOT INSTALL THE STITCHER. Notify your nearest representative and the carrier who delivered your stitcher.

Make certain that you get a signed copy of the Carrier Inspector's Report of the damage incurred.

ASSEMBLY

1. Clamp or bolt the Magnatek head to your machine
2. Install Wire Guide Spring into wire guide bracket of Magnatek Head.

THREADING WIRE AND ADJUSTING WIRE STRAIGHTENERS (See fig. 1)

1. Draw wire (Index A) by hand, from the coil.
2. Thread the wire through the slot (Index B) at the end of the wire guide spring, through the wire guides (Index C), through the upper wire straightener (Index D), and through the lower wire straightener (Index E).

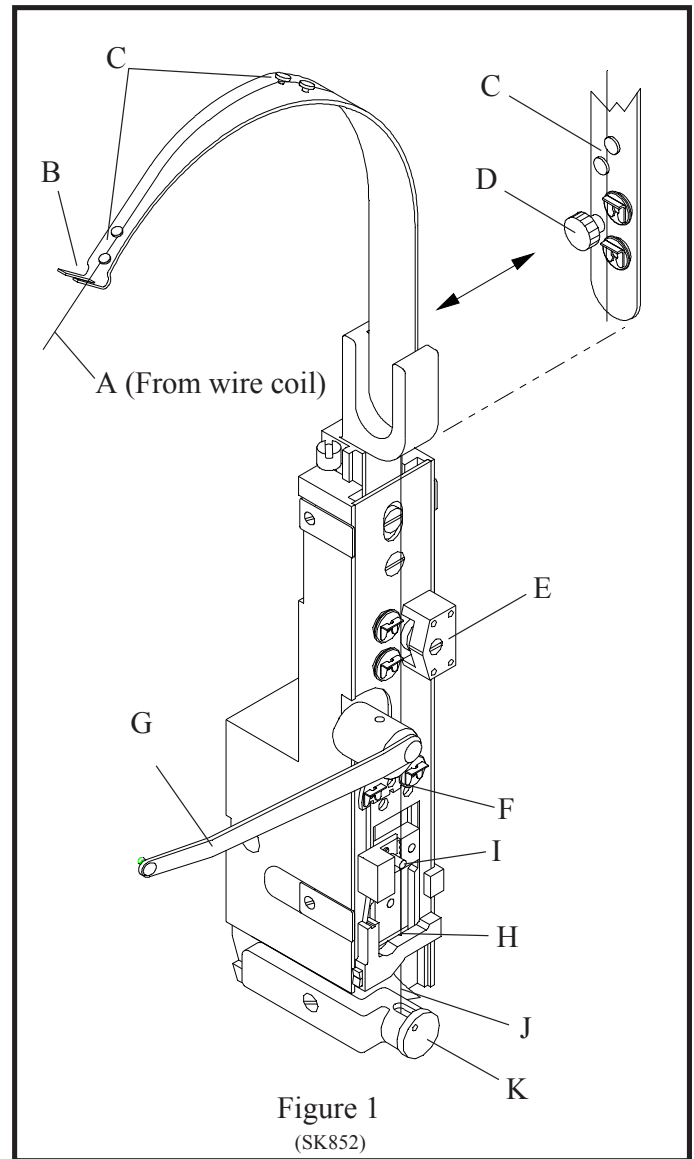

3. Release the rotator operating spring (Index G) from the rotator and swing it to the left. Remove Rotator (Index K).
4. Thread the wire between the tension pawl and tension roll (Index F). Feed the wire through the wire cutter lead-in hole (Index H) in the bottom of the face plate.
5. Push grip post to left to open the grip (Index I). Insert wire and release the post so that the grip engages the wire for feeding into the rotator.
6. To check adjustment, hold open grip (Index I) and pull about 1 1/2 feet of wire from below face plate. Cycle machine once by hand to cut wire. Cycle machine again by hand to observe wire straightness. The wire (Index J) should point straight down, prior to being cut.

7. Adjust the upper wire straightener, beginning at position shown, (Index D) so that the wire points straight down. Adjust the lower wire straightener, beginning at the 3:00 o'clock position, (Index E) so that the wire (Index J) feeds straight down.
8. Replace the rotator and rotator operating spring.

NOTE:

When changing coils or wire sizes, check straighteners to insure proper wire feed.

**STITCHING HEAD
LUBRICATION
(See fig. 2)**

Important! The stitching head must be lubricated before each spool of wire (50,000 to 70,000 stitches). Use **Deluxe / ISP** lubricant #CA9640.

- A. Inject lube into hole, or remove and lube shaft.
- B. Remove rotator spring and lube shaft.
- C. Inject a small amount of lube on cam surface of driver bar above and below grip housing.
- D. Wipe area clean, and inject a small amount of lube on grip release cam.
- E. Wipe driver clean, and apply a layer of lube.
- F. Inject lube into cutter operating slide.
- G. Very important! Remove rotator and clean inside of rotator holder.
- H. Carefully clean the rotator and apply lube to its body.
- I. Apply lube to the rotator's ramp.

For heavy duty applications, periodically disassemble the head and clean the parts. Lightly lube all sliding surfaces using **Deluxe / ISP** lubricant #CA9640. Double check lube points A through I.

CAUTION

Do not operate stitcher until operating instructions have been read and understood-do not operate stitcher at anytime without work under the head.

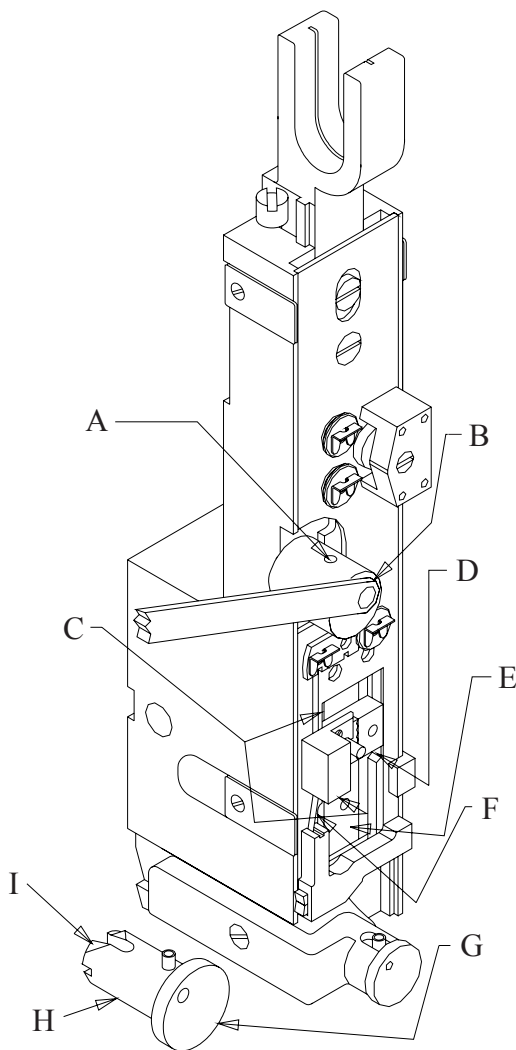

Figure 2
(SK852A)

Section 4

OPERATION

General:

After having properly installed and set up the machine, it is now ready for stitching. It is recommended that each operator be instructed as to correct operating procedure and normal adjustments necessary for varying work conditions.

WARNING

Prevent accidents by following these rules:

1. Do not put your hands near area to be stitched when machine is operating.
2. Turn the power off when the stitcher is not in use.

CAUTION

AVOID DAMAGE TO YOUR STITCHER BY FOLLOWING THESE RULES:

1. Never operate your stitcher with wire feeding unless you have work material between the clinchers and formers.
2. Do not drive one stitch on top of another.

Changing Work Thickness: (See Fig. 3)

Changing work thickness will probably require a change of the wire draw length used to make a stitch. This is done by raising or lowering the face plate. Change face plate position as follows:

1. Switch off power, loosen the face plate screw (Index A).
2. Turn grip release lever (Index B) clockwise to raise face plate for more wire draw or counter clockwise to lower face plate for less wire draw.

NOTE: Raising face plate too high may: (1.) Prevent the grip from closing and drawing wire; (2.) Prevent proper compression resulting in a loose stitch.

3. Retighten faceplate screw.

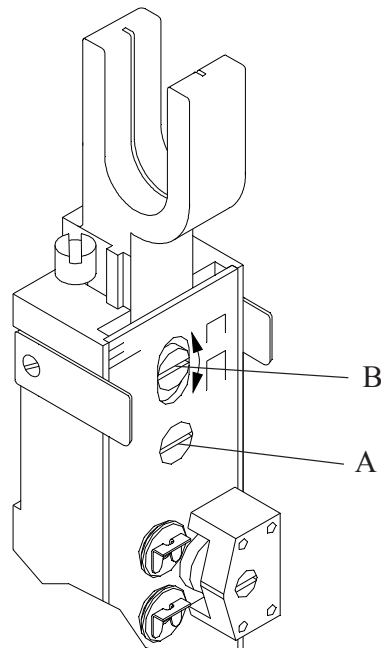

Figure 3
(SK852B)

Section 5

MAINTENANCE, TROUBLE SHOOTING AND ADJUSTMENTS

General

The Magnatek Stitcher is a friction-type head which depends on smooth sliding friction and proper timing to function correctly. Preventative maintenance will go far to insure trouble-free operation. Avoid production down time by keeping your stitcher lubricated and in top working condition at all times.

Recommended Spare Parts

Like any equipment that has moving parts, certain parts of your stitcher will be subjected to more wear than others and require replacement. The following listing includes all the parts required for minimum maintenance and good operation.

<u>PART NAME</u>	<u>QTY.</u>
Wire Cutters	2
Grip	1
Grip Spring	1
Driver	1
Tension Roll Clip	2
Rotator	1
Clincher Points	2

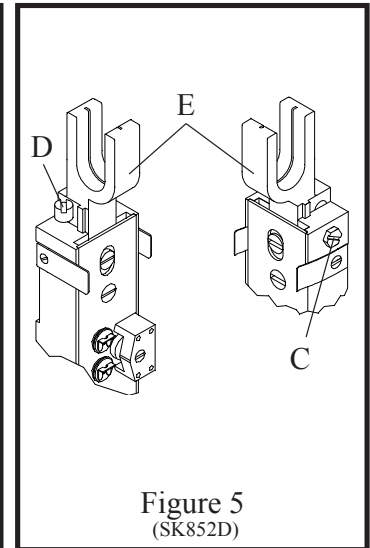
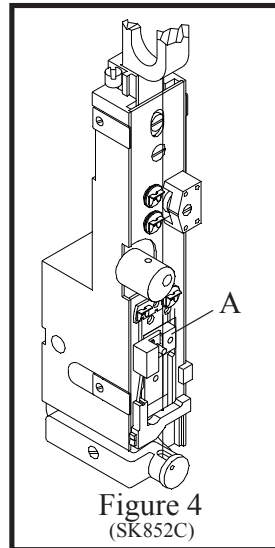

CAUTION

MAKE ALL ADJUSTMENTS WITH THE POWER OFF AND THE STITCHING HEAD IN NEUTRAL POSITION! (Fig. 4)

In neutral position, the wire grip assembly (Index A) is stopped at the top of the slot in the face plate.

Stitching Adjustments

Best stitching performance will be assured if all adjustments are made so that you get the following results:

1. Good Cut-Off
2. Uniform Wire Draw
3. Equal Leg Length
4. Proper Clincher Alignment
5. Sufficient Compression

To Equalize Both Legs of Stitch (See fig. 5)

1. Loosen the wire guide locking bolt (Index C).
2. Turn adjusting screw (Index D) clockwise to shorten left leg of stitch; counter clockwise to lengthen left leg.
3. Tap bracket (Index E) down before tightening screw (Index C).

Magnatek Head Trouble Shooting





HERE'S HOW A PERFECT STITCH LOOKS

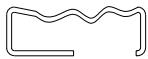
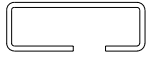

Should stitches appear in any form other than illustrated, one or more kinds of mechanical trouble may have caused the malformation. The possible causes and remedies are given for each kind of mechanical trouble and are listed under each section. The remedies are indexed to the Adjustments Section which gives more detailed information about your stitcher, the mechanical trouble that may occur and suggested remedies. Unless you recognize the correct cause, check each possible cause given.

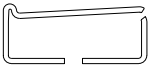
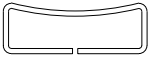
TROUBLE	POSSIBLE CAUSE	REMEDY
A. Defective Stitches		
<p>1. One or both legs buckled.</p>  <p>NOTE: Since buckled legs are often concealed in the work and may appear the same as a short leg, always remove two or more stitches to see which is occurring.</p>  <p>2. Wrinkled crown.</p>	<ol style="list-style-type: none"> 1. Clincher is worn or improperly aligned. 2. Insufficient compression. 3. Unequal leg length 4. Burred stitch leg. 5. Incorrect wire size. 6. Worn bender bar. 	<p>"B,C" Page 12,13</p> <p>"A" Page 12</p> <p>See "To Equalize Both Legs of Stitch" Page 8</p> <p>"J" Page 16</p> <p>"L" Page 17</p> <p>"D" Page 13</p>
<p>3. Length of one leg varies</p> 	<ol style="list-style-type: none"> 1. Leg Lengths not adjusted properly 2. Gripper is worn or dirty 3. Grip release slide is worn 4. Broken wire guide spring (Figs 20 page 22) 5. Excessive tension on wire straightener 6. Worn Driver bar 7. Worn Tension Pawl or weak tension pawl spring 8. Weak or broken grip spring 	<p>See "To Equalize Both Legs of Stitch" Page 8</p> <p>"I" Page 15</p> <p>"I" Page 15</p> <p>Replace</p> <p>"N" Page 18</p> <p>"F" Page 14</p> <p>"P" Page 19</p> <p>"I" Page 15</p>

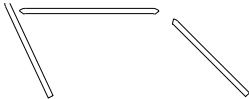
Magnatek Head Trouble Shooting

TROUBLE	POSSIBLE CAUSE	REMEDY
4. Corner of crown distorted or fractured 	1. Excessive compression 2. Broken driver end 3. Worn bender bar 4. Clincher improperly aligned or worn 5. Incorrect wire size	"A" Page 12 "G" Page 14 "D" Page 13 "B,C" Page 12,13 "L" Page 17
5. Stitch crown not flat and legs not bent into work 	1. Insufficient compression	"A" Page 12
6. One or both legs turn out 	1. Clincher improperly aligned 2. Dull cutters	"C" Page 13 "J" Page 16
7. Flat piece of wire 	1. Rotator is dirty 2. Improperly adjusted lower wire straightener 3. Broken or worn rotator 4. Improperly aligned rotator	"M" Page 17 "N" Page 18 "M" Page 17 "M" page 17
8. Stitches come out in pieces 	1. Improperly aligned rotator 2. Weak rotator operating spring 3. Improperly adjusted upper wire straightener 4. Incorrect wire size 5. Wire jammed in bender bar grooves	"M" Page 17 "M" Page 17 "N" Page 18 "L" Page 17 "D,G" Page 13,14
9. Both stitche legs are either too long or too short 	Face plate not adjusted properly	See "Changing Work Thickness" Page 7

Magnatek Head Trouble Shooting

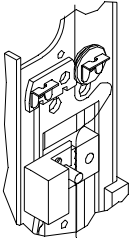
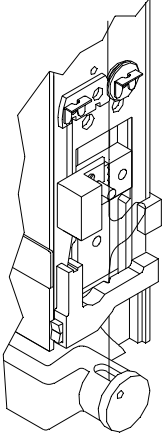
TROUBLE	POSSIBLE CAUSE	REMEDY
B. WIRE BUCKLES		
1. Wire buckles above the grip and below the tension pawl  <p style="text-align: center; font-size: small;">(SK852E)</p>	1. Worn driver bar 2. Worn bender bar latch 3. Worn or broken bender bar friction plug and/or spring	"F" Page 14 "H" Page 15 "E" Page 14
2. Wire Buckles above the wire cutters and below the grip  <p style="text-align: center; font-size: small;">(SK852E)</p>	1. Improperly aligned rotator 2. Worn or broken wire cutters 3. Burrs on rotator 4. Improperly adjusted lower wire straightener 5. Worn or broken wire cutter operating slide 6. Wire cutter slot in face plate worn	"M" Page 17 "J" Page 16 "M" Page 17 "N" Page 18 "K" Page 17 "J" Page 16
C. GRIP		
1. Grip does not close	1. Face plate is too high	See "Changing Work Thickness" Page 7

CAUTION

**Turn Power OFF Before
making Any Adjustments**

A. Insufficient or Excessive Compression

Proper compression of work between the clincher and the bender bars is necessary so that the stitch penetrates the work material and clinches correctly. To test for compression, drive several stitches into sample work material. With proper compression, stitches hold the work together firmly and the clinched legs do not overlap. In the following instances, either one or all of the conditions may exist: with insufficient compression, stitch legs overlap, crown of the stitch is fractured, and the work mutilated. The method for obtaining proper wire draw and compression is detailed in the Operation Section on Page 7 under the heading, "Changing Work Thickness".

B. Clincher (See fig. 6)

The purpose of the clincher is to turn the legs of the stitch back after they have penetrated the work material. There are two types of clinchers:

1. Solid (stationary) Type-makes a loop clinch.
2. Activated (moving) Type-makes a flat clinch.

With the Solid (stationary) Type clincher, the legs of the stitch must strike the clincher at the same time and with equal spacing from the outside edges of the grooves. The grooves in the clincher should be smooth. Any interference (particularly worn or pitted grooves), which change the original radii, will cause the stitch legs to buckle and/or the corners of the crown to fracture.

With the Activated (moving) Type clincher, the stitch legs must enter the clincher at the same time

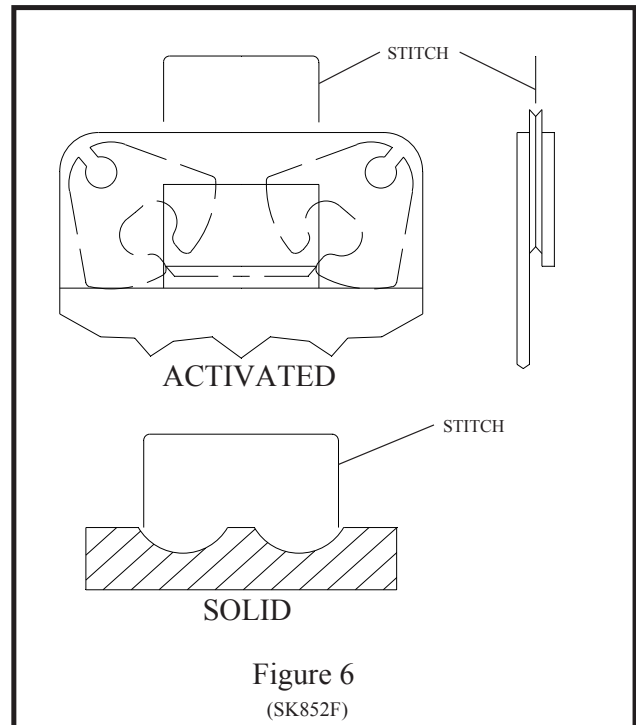

Figure 6
(SK852F)

and with equal spacing from each side. When the stitch legs have penetrated the work material, the moving clinchers are raised to bend the legs towards each other and up flat against the work. The clincher points must bend both legs of the stitch against the work with the same force. Clincher points must always move freely and not bind. Dirt, wire chips, etc. will cause the points to bind.

The clincher points are in a retracted position in the clincher box until the stitch legs penetrate the work material. After the legs penetrate, the clincher points move upward to give a neat, flat clinch against the bottom surface of the work material. If the clincher points remain in the up position, the legs of the next stitch cannot penetrate the work material, causing the stitch legs to buckle and/or the corners of the crown to fracture. Examine the clincher points, clincher slide for possible binding. Clean and oil.

If clincher points rise to high, they fracture the stitch legs and/or mar the work. If the points do not rise high enough, the legs will not clinch flat. Adjust the height of the clincher points. For most work the clincher points should rise to be level with the top of the clincher housing.

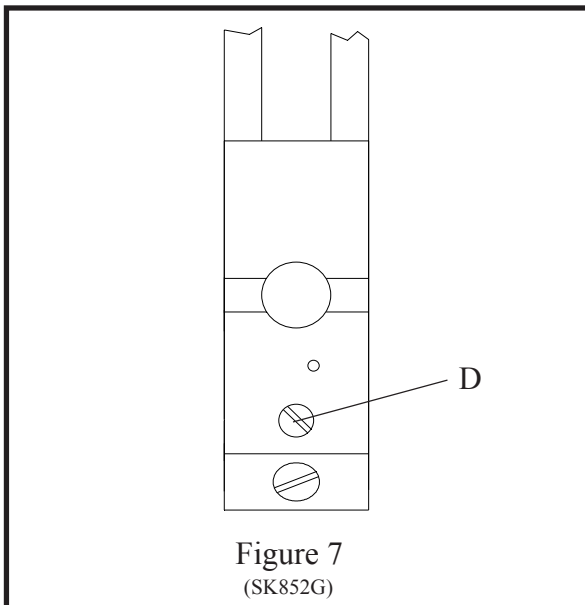

Figure 7
(SK852G)

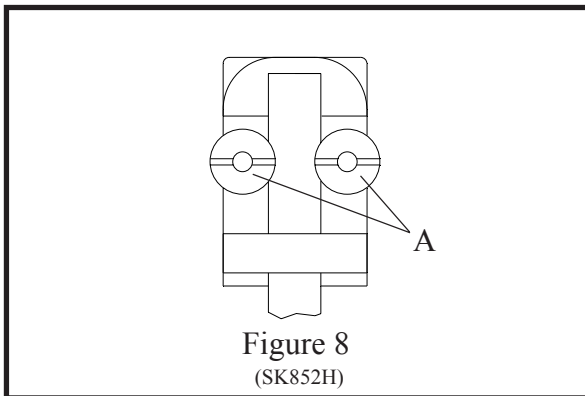

Figure 8
(SK852H)

C. Head/Clincher Alignment (See fig. 7)

To test alignment: Drive several stitches into a section of material identical to that which is to be stitched. The clinched legs should be identical and aligned with each other. If the legs are not in alignment make one of the following adjustments:

1. To adjust for front-to-rear alignment: (Fig. 7)
 - a. Turn power off. Cycle the stitcher by hand until legs of the stitch appear just below the bender bar to determine if the head should be moved to the front or rear.
 - b. Remove stitcher from machine.
 - c. Turn the head aligning screw (Index D) clockwise to move the head backward; counterclockwise to move the head forward.
 - d. Install stitcher head on machine.

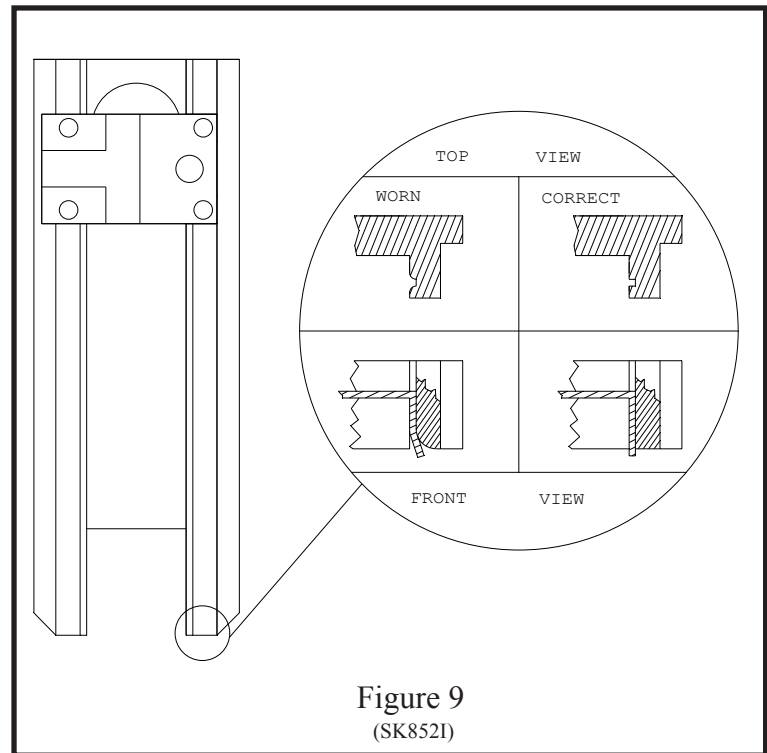

Figure 9
(SK852I)

2. To adjust for side-to-side alignment: (Fig. 8)
 - a. Turn power off. Cycle the stitcher by hand until legs of the stitch appear just below the bender bar to determine how far the head or clincher should be moved to the side.
 - b. Loosen clincher plate binder nuts (Index A).
 - c. Move clincher to left or right as required.
 - d. Tighten binder nuts.

D. Bender Bar (See fig. 9)

The bender bar bends the wire over the rotator and forms it into an unclinched stitch. The legs of the stitch are guided towards the work material by the bender bar grooves. The legs of the unclinched stitch should be perpendicular to the crown. When the bender bar grooves become worn, the legs tend to flare out (Figure 9) as they emerge from the grooves. This causes the legs to strike the clincher improperly. As a result, one or both legs will crumple and a broken driver bar or a broken bender bar can result. If the lower end of the bender bar grooves become chipped, it will not support the wire and may cause the stitch to break at the crown. Replace the bender bar assembly (See "H" page 15 or Fig. 10). Other bender bar functions are related to wire cutting ("J" page 16), and driving ("G" page 14).

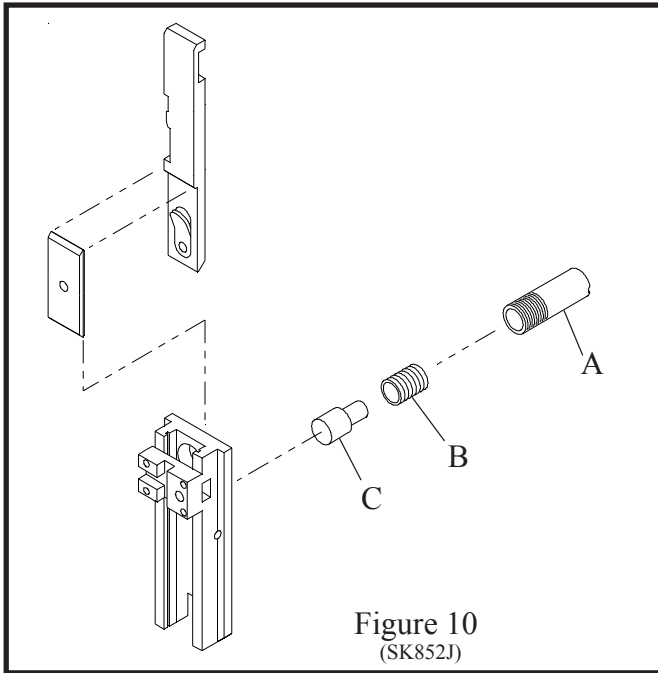

Figure 10
(SK852J)

E. Bender Bar Friction Plug And/Or Spring (See fig. 10)

Two parts furnish pressure to coordinate movement of driver bar and bender bar. If pressure is insufficient, proper timing is not maintained for the action of the grip. As a result, wire feeds backwards. Replace the plug and/or spring.

To replace bender bar friction plug and/or bender bar friction spring:

1. Remove bender bar assembly by following steps 1 through 16 of "Dismantling Magnatek Stitching Head", Pages 20 and 21.
2. Remove bender bar friction bushing (Index A). Bender bar friction plug (Index C) and spring (Index B) will be released forward from bender bar assembly.
3. Replace plug and/or spring and reassemble.

F. Driver Bar (See fig. 11)

The driver bar (Index A) has several functions:

1. It imparts the downward thrust from the driving slide assembly (Index B) to the bender bar assembly (Index C) and the driver (Index D).
2. It returns these parts to the neutral position on the upstroke.

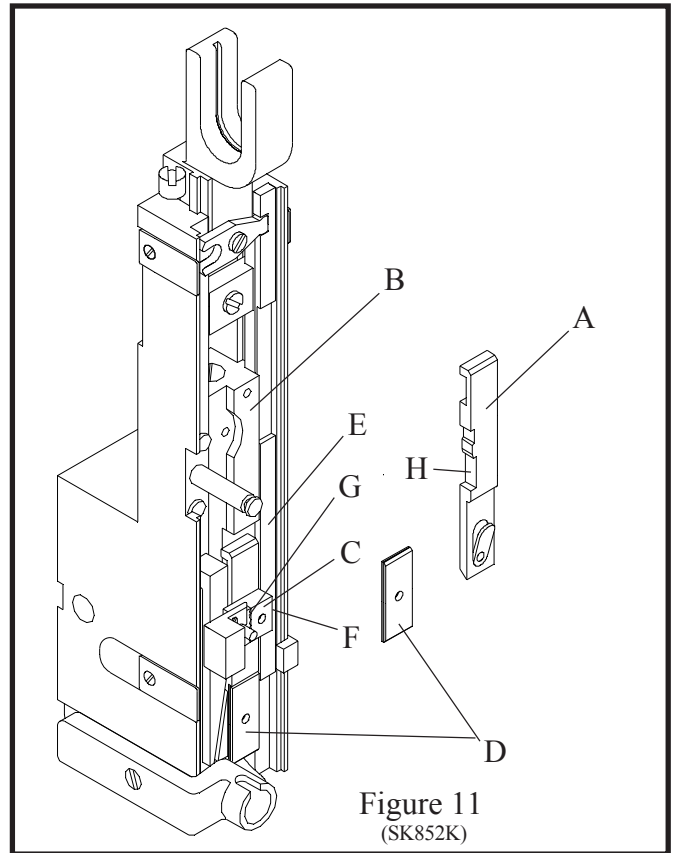

Figure 11
(SK852K)

3. In conjunction with the grip release slide (Index E), it controls the movement of the bender bar latch (Index F) that opens and closes the grip (Index G).

If the notches (Index H) at the top left side of the driver bar become worn, the grip will not remain open on the upstroke. As a result the wire feeds backwards and buckles above the grip and below the tension pawl. Worn notches can also cause uneven wire draw. Replace the driver bar. While driver bar is out for inspection check the driver end retaining spring for proper tension and to make certain there is not dirt lodged behind it.

The notches shown on left side of driver bar play an important part in function of bender bar assembly therefore, corners should be free of dirt and notches not marred.

G. Driver

The driver rides within the bender bar grooves as part of the bender bar assembly. As this assembly reaches the lower contact point of the cam in the grip release slide, the bender bar latch is forced inward, releasing the wire grip and permitting the bender bar assembly to continue downward with

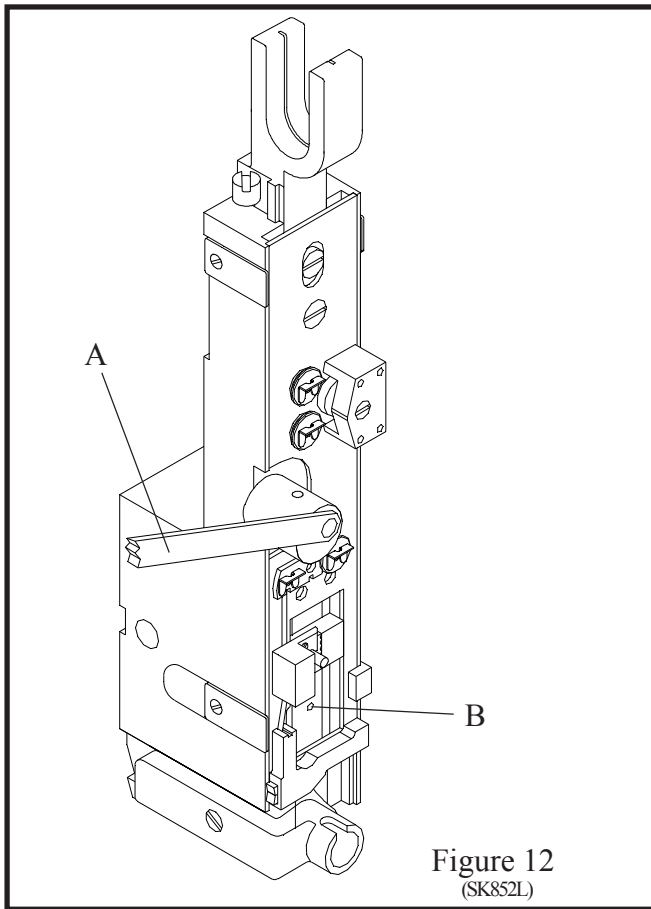

Figure 12
(SK852L)

the driver riding on top of the formed stitch. When the bender bar is stopped against the work material, the driver continues downward to exert pressure on the crown of the stitch, driving it through the work material.

If the driver is chipped it allows the legs of the stitch to back up into the broken area. This causes the corner of the crown to fracture or a "spike" section to protrude above the crown. A chipped driver is usually the result of driving a stitch on top of another stitch. A worn driver often causes deformed stitches or fracturing at the corners of the crown. The driver is reversible for longer use.

Occasionally, a stitch is caught behind the driver. This causes improper alignment of the driver. As a result, successive stitches are distorted at the crown. Remove the driver and clean the bottom portion of the driver bar.

To remove the driver: (See fig. 12)

1. Cut the wire at the bracket and pull the loose end out.

2. Swing the rotator operating spring (Index A) to the left.
3. Remove the rotator.
4. Insert a pointed object into the hole (Index B) on the driver and press in on the high end of the spring which is located behind it.
5. Slide the driver down and out of the head.
6. Clean, reverse or replace the driver.
7. Reassemble.

H. Bender Bar Latch

The bender bar latch opens and closes the grip and is actuated by the grip release slide and driver bar. If the contact points of the latch become worn, timing of the grip is erratic and uneven wire feed results. A dirty latch will decrease pressure of the grip on the wire. This causes wire slippage. Clean or replace the latch.

I. Grip, Grip Release Slide and Face Plate: (See fig. 13)

The grip spring (Index A) exerts pressure on the benderbar latch (Index B) to close the grip (Index C) at the start of the down stroke. The grip release slide (Index D) actuates the bender bar latch at point X to open the grip after the correct amount of wire has been fed to make a stitch. The serrated teeth on the grip must be sharp or slippage will occur, producing uneven wire draw.

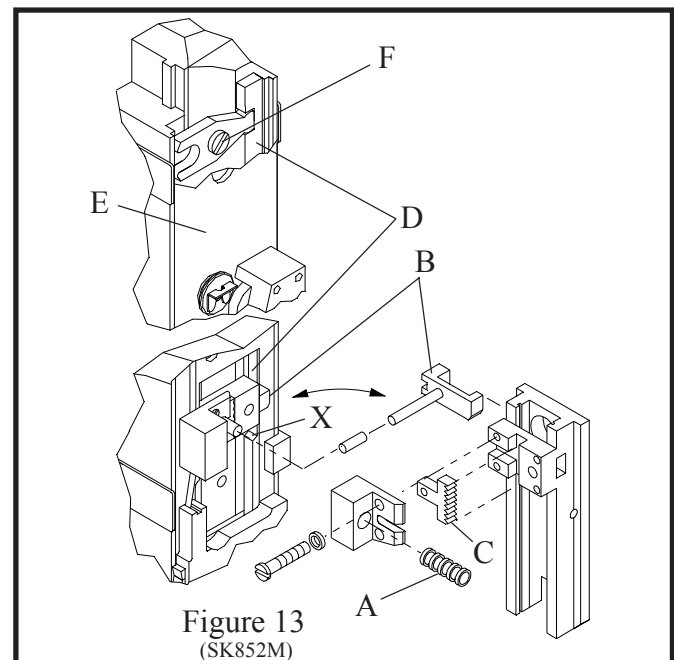

Figure 13
(SK852M)

When the face plate (Index E) is adjusted (See "Changing Work Thickness", page 7) a pivotal action (at point F) changes the position of the grip slide. When the face plate is raised, it moves the grip release slide down. The gripper can then remain closed longer, on the down stroke, feeding more wire for the stitch. When the face plate is lowered, it moves the grip release slide up. The gripper will open sooner on the down stroke, feeding less wire for the stitch.

If the grip is weak, uneven wire draw will result. Replace the grip spring. If the contact points on the grip release slide and/or the bender bar are worn, wire adjustment will not remain accurate.

The face plate stops the bender bar assembly at the top of its stroke and allows the bender bar latch to close the grip. When the face plate is too high, too much of the upstroke has been used before the bender bar hits the face plate. In the remaining portion of the upstroke, the driver bar cannot continue upward enough to release the bender bar latch so that it can close the grip.

J. Wire Cutters: (See fig. 14)

The purpose of the wire cutters is to shear the wire cleanly. There are two wire cutters, upper and lower. The upper wire cutter (Index A) receives wire from the grip through the wire cutter lead-in-hole (Index B). It also serves as the cutoff die. The lower wire cutter (Index C) is the cutting knife. If the cutter breaks, it will cover the lead-in hole. This prevents the wire from feeding into the rotator. If the cutting surfaces become worn, burrs will result on the end of the wire. This prevents the wire from feeding into the rotator. As a result, the wire buckles between the cutters and the wire grip. Reverse, interchange or replace the cutters.

To Reverse, Interchange, or Replace the Wire Cutters:

1. Loosen both face plate retaining clips (Index D) at bottom of bonnet.
2. Spring the face plate out 1/8" while holding the cutter slide in position (Index E).
3. Slide the cutters out to the left.

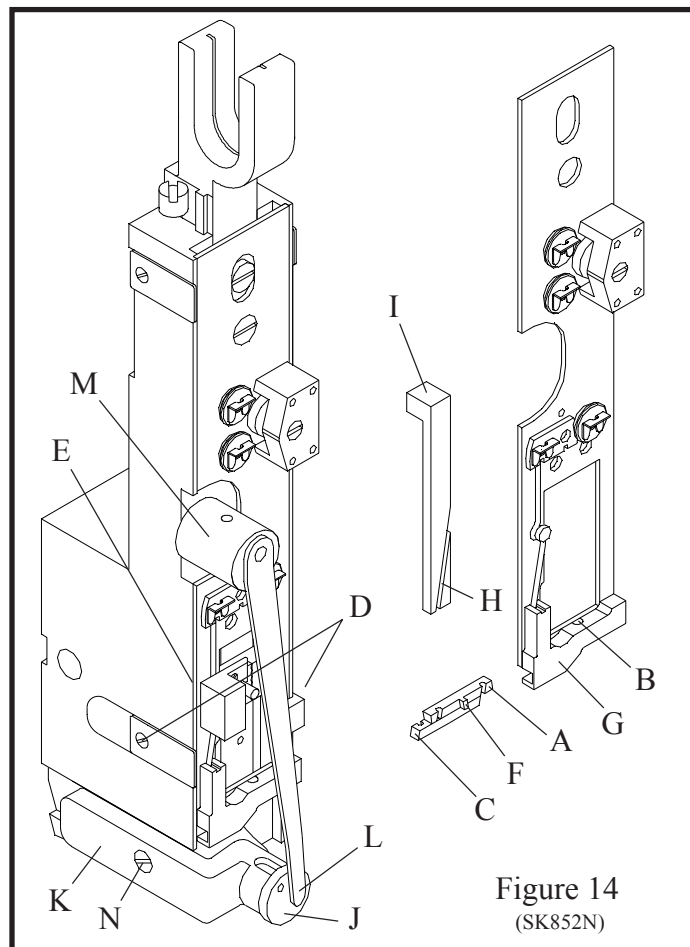

Figure 14
(SK852N)

4. Reverse, interchange or replace the cutters.

NOTE

While installing the cutters, make sure that (1): lip on upper cutter (Index F) fits into the recess behind the face plate (Index G) and (2): that the lip on the bottom cutter fits into the slot (Index H) in the wire cutter operating slide (Index I).

The wire cutter operating slide actuates the lower wire cutter. If the slide is worn or broken, the wire cutter is not actuated. Replace the operating slide. The slot in the lower part of the face plate contains the wire cutter and maintains a close fit for wire shearing. If this slot becomes oversized, the wire will not be cut off. Replace face plate. **To Replace Face Plate (See Steps 1 through 8, "K" page 17).**

NOTE: (See fig. 15)

The lug (Index C) in the faceplate must match the slot (Index D) in the grip release adjusting lever (Index E) or damage to the head may result.

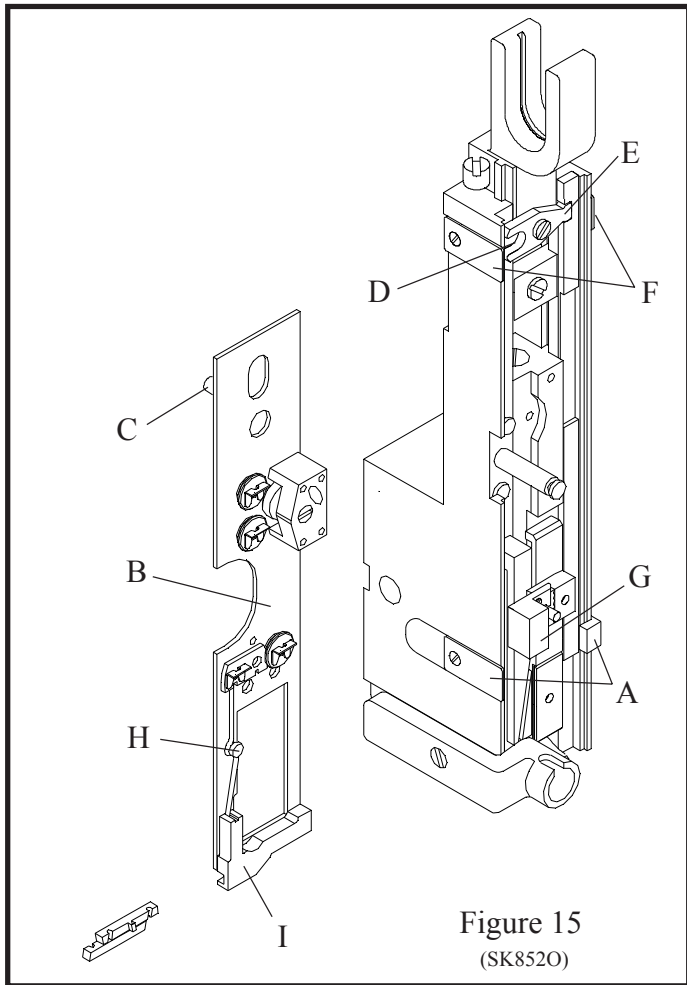

Figure 15
(SK8520)

K. Wire Cutter Operating Slide

The wire cutter operating slide actuates the lower wire cutter which acts as the cutting knife. If the slide is worn or broken, the wire cutter is not actuated. Replace the operating slide.

To Replace The Wire Cutter Operating Slide:

1. Cut the wire at the bracket and pull the loose end out.
2. Remove the stitcher head assembly.
3. Lift end of spring (Index L, Figure 14) out of rotator.
4. Swing the spring up to disengage it and lift out.
5. Slip the rotator operating cam (Index M, Figure 14) forward and off the stud.
6. Pull the rotator forward.
7. Loosen the two face plate retaining clips (Index A, Figure 15) and rotate them downward.

8. Push two face plate retaining clips (Index F) outward while lifting face plate up to release face plate.
9. Position grip spring housing (Index G) between tension pawl spring retainer (Index H) and cutter housing (Index I).
10. Remove face plate (Index B) by sliding face plate to the left and lifting up.
11. Remove the cutter operating slide (Index I, Figure 14).
12. Insert a new cutter operating slide.
13. Reassemble

L. Proper Wire

Depending on which Magnatek head is being used the wire range may be: 25 to 30 gauge round; 24 gauge round; 20x25 or 21x25 flat. 120,000 to 159,000 psi tensile strength bookbinders wire should be used.

If the wire used is larger than the bender bar grooves were designed for, it will fracture at the stitch corners and come out in pieces. Also, serious damage to the stitcher may result. If the wire used is smaller than the bender bar grooves were designed for, the legs of the stitch do not fit snugly in the grooves and may tend to buckle when they strike the work material because they are not fully supported.

M. Rotator (See fig. 14)

The rotator (Index J) (1) receives the wire from the cutoff die, (2) holds the wire while it is being cut, then (3) turns it to a horizontal position, moves it under the bender bar grooves and (4) supports the wire while it is being formed into a "U-shaped" stitch.

The wire lead-in-funnel of the rotator must be aligned with the wire as it comes through the wire cutters. If the rotator is improperly aligned, the wire hits the rotator and buckles. Adjust upper two wire straighteners until wire slips past rotator. Burrs on the rotator prevent the wire from entering the rotator. This causes wire buckling. Remove the rotator and polish the lead-in radius.

The magnets in the rotator hold the wire firmly in the rotator. If a magnet is broken or chipped the wire may fall out. To determine if the rotator has the proper holding strength, remove the rotator and insert a cut length of wire in the rotator. Hold rotator between thumb and forefinger. Attempt to jar wire loose by hitting heel of hand on top of table or against other hand. With proper magnetic holding force wire will remain in rotator. With insufficient holding force wire will fall from rotator. Replace the rotator.

The rotator holder and rotator operating spring are responsible for alignment of the wire beneath the bender bar grooves. The position of the rotator holder determines how far the rotator is pushed forward under the bender bar by the rotator operating spring (Index L, Figure 14). A weak spring will not push the rotator in far enough and with this improper alignment the bender bar will knock the wire from the rotator or will shear the wire into pieces. To secure proper alignment, check the position of the rotator holder and the tension applied by the rotator operating spring. Make any necessary adjustment of the rotator holder or replace the rotator operating spring if weak.

The wire is fed into the rotator and held for forming. If the rotator is dirty, the wire is not gripped securely enough and drops out. Remove and clean the rotator. If the edges over which the wire is formed are sharp, the corners of the stitch crown will fracture. Remove the rotator and polish the edges with a fine emery cloth.

To remove, Adjust or Replace the Rotator Holder:

1. Swing the rotator operating spring to the left.
2. Remove the rotator.
3. Loosen the rotator holder screw (Index N, Figure 14).
4. Adjust the rotator holder screw.
5. Reassemble.

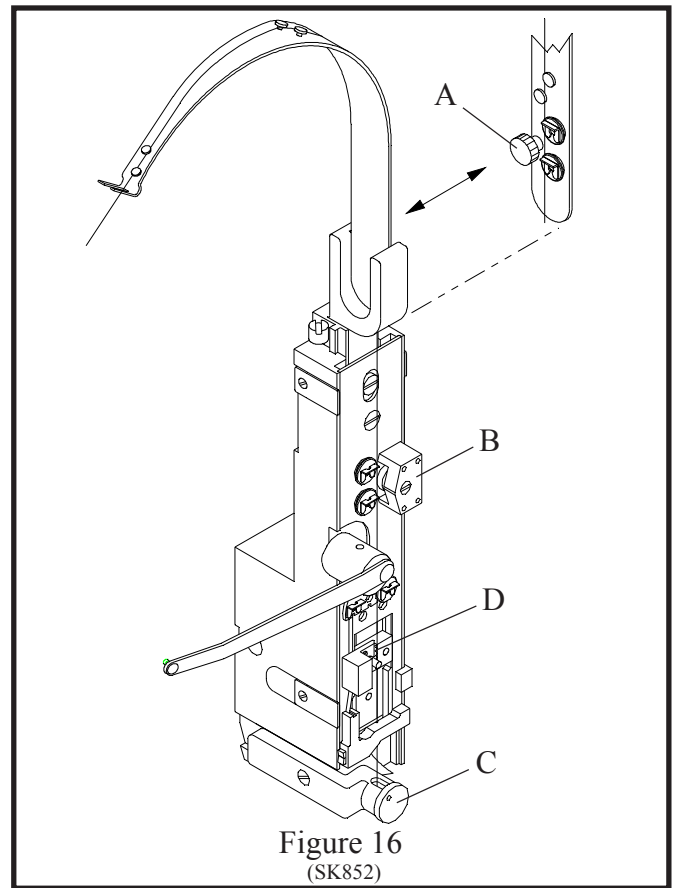

Wire Straighteners (See fig. 16)

All coils of stitching wire have a certain amount of bundle curve. The purpose of a wire straightener is to remove this curve. There is both an upper wire straightener (Index A) and a lower wire straightener (Index B) on all Magnatek Model Stitchers. See "Threading Wire and Adjusting Wire Straighteners" page 5.

The upper wire straightener should feed wire parallel to the faceplate. This insures that the wire will properly enter the rotator and will be aligned with the grooves in the bender bar.

If the wire is not parallel to the face plate the wire is sheared in the rotator as the bender bar descends. Adjust the upper wire straightener.

The lower wire straightener directs the wire straight down so that it enters the rotator (Index C). If the wire is not straight enough it hits the rotator and buckles. Adjust the lower wire straightener so that

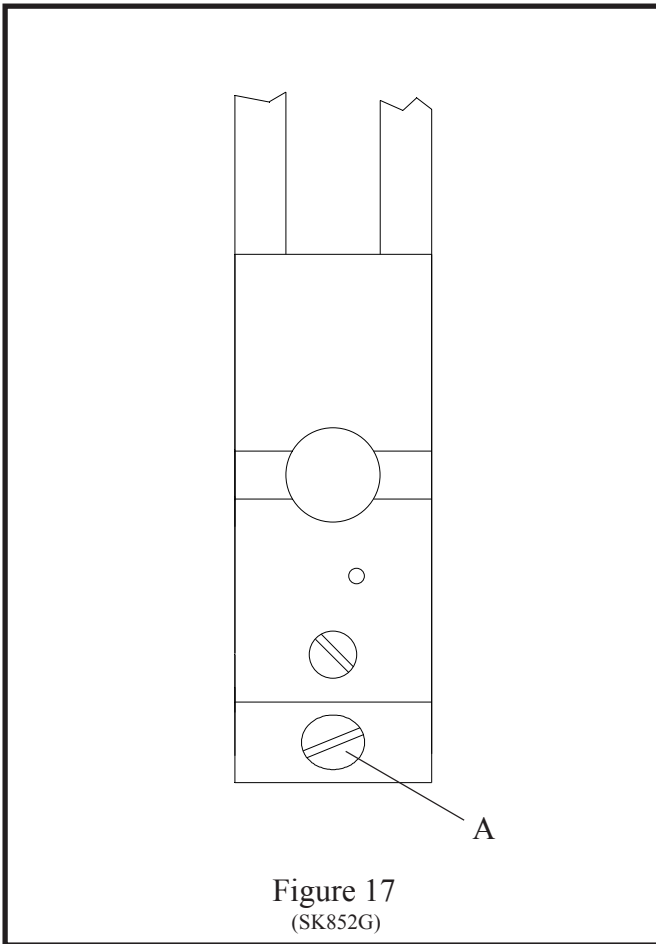

the wire points straight down as in figure 16. Improper straightening of the wire can also cause the stitch legs to buckle or turn out because they strike the clincher improperly. Excessive tension on the wire straightener prevents the grip (Index D) from feeding the wire smoothly. This causes variation in leg length.

NOTE:

Check the wire straighteners when changing the coils to insure the accurate feeding of wire.

O. Supporter

The supporter furnishes the necessary support to the inside surface of the stitch so that it does not buckle as it is being driven into the work material. A lack of (or insufficient) support will often cause the stitch crown to wrinkle or the legs of the stitch to buckle. Tighten the supporter spring bushing (Index A, Figure 17) or replace the spring.

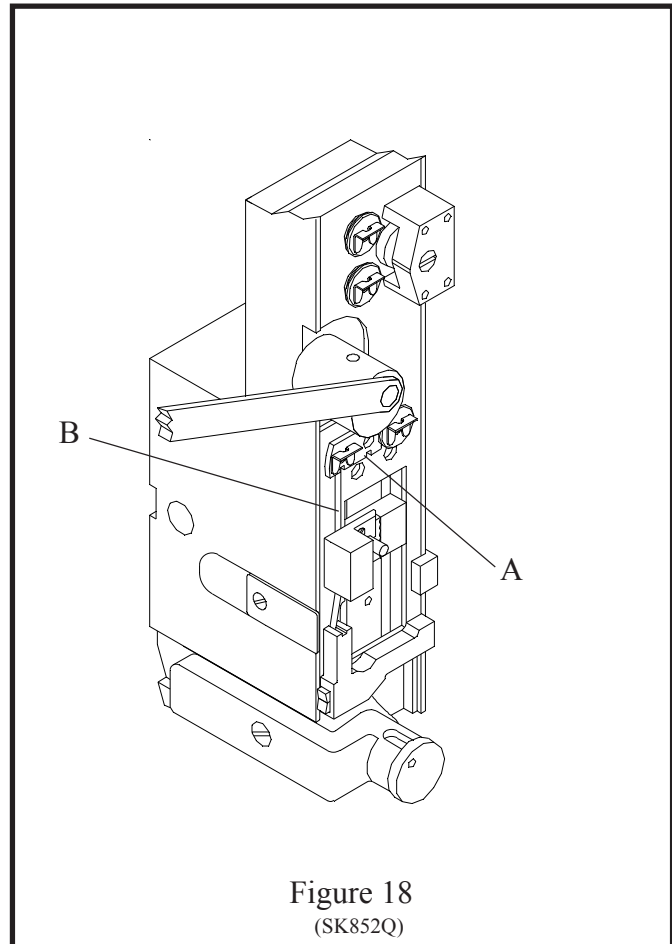

If the corners of the top surface of the supporter are too sharp, or nicked, the corners of the stitch crown will fracture. If operating properly the supporter should function as follows:

1. When the bender bar touches the work material and the legs of the stitch are about to leave the bender bar grooves the supporter should be touching the underside of the crown.
2. As the stitch is driven through the work the supporter is gradually retracted by the driver. It should remain under the crown of the stitch until the last instant before the crown touches the work material.

P. Tension Pawl: (See fig. 18)

The tension pawl (Index A) and spring (Index B) apply pressure on the wire to prevent back feed. If the pawl becomes worn or the spring becomes weak, the wire feeds backwards resulting in a short wire draw. Reverse or replace the tension pawl and/or spring.

DISMANTLING MAGNATEK STITCHING HEAD

CAUTION

As a precautionary measure-When removing the head from any stitching machine make **SURE** that the power to the machine has been turned **OFF** or disconnected.

CAUTION

The rotator operating cam can be installed backwards. Be sure to read and follow the instructions on page 21 before reassembling.

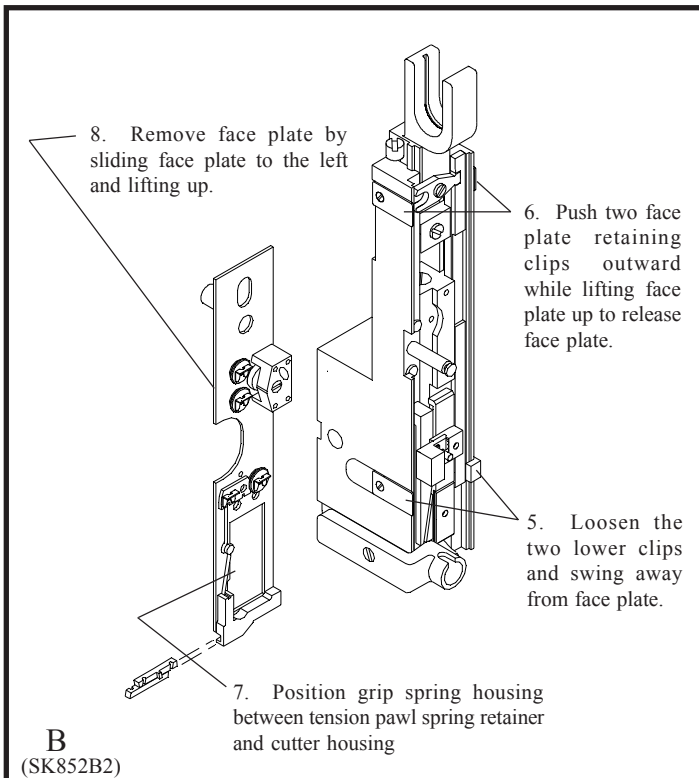
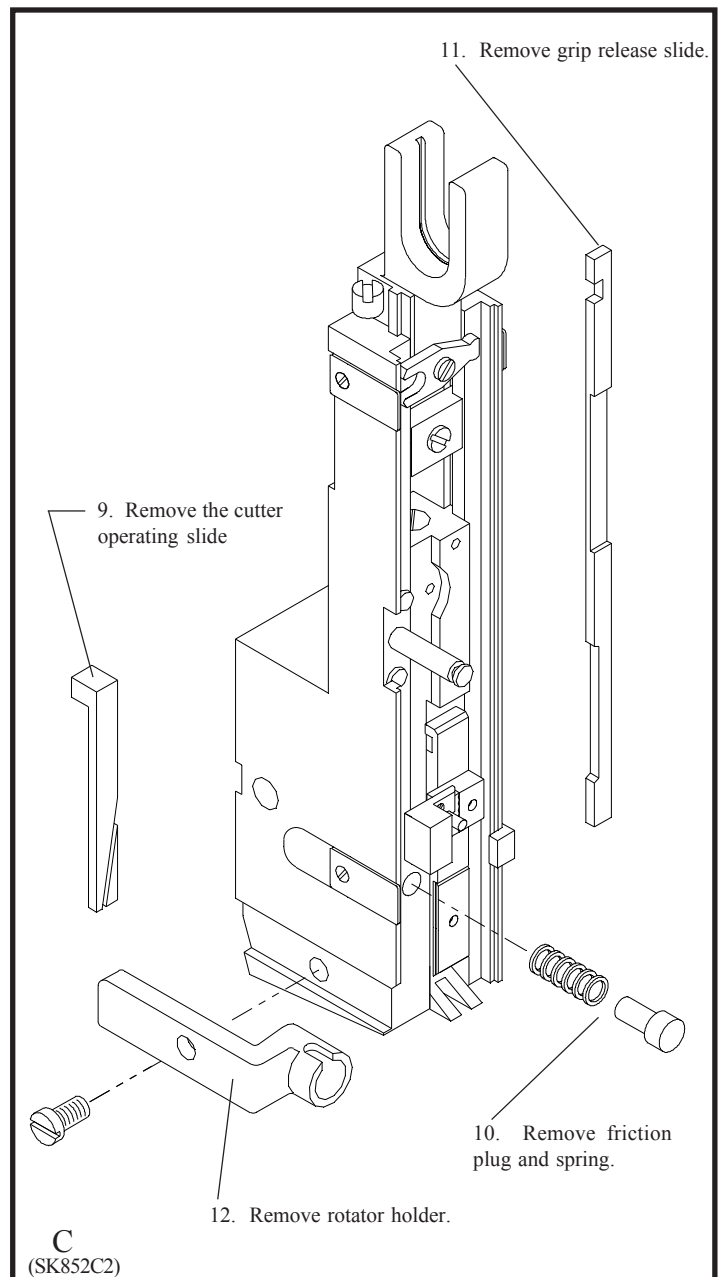
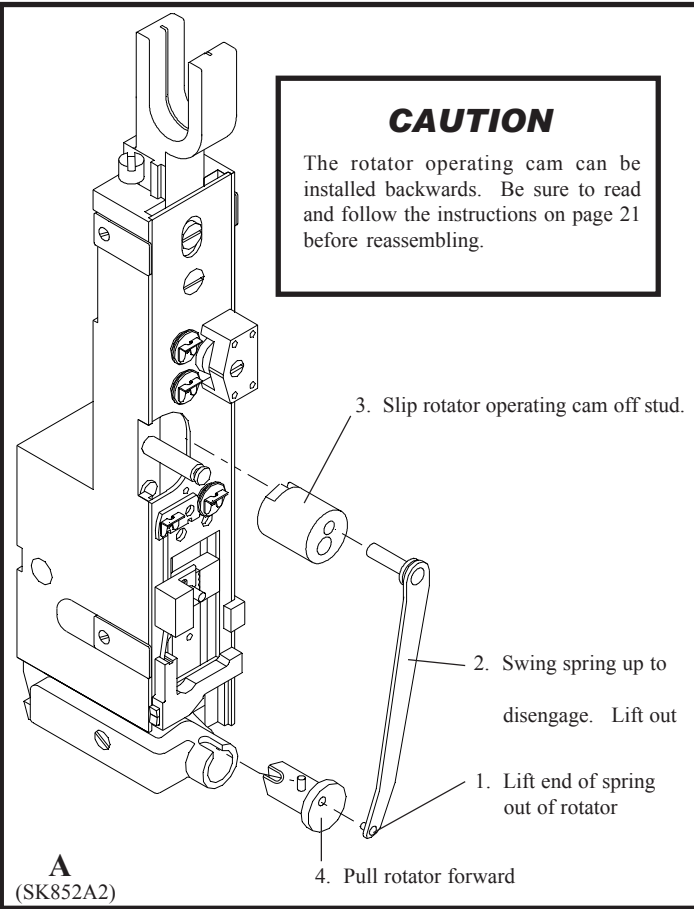

DISMANTLING/REASSEMBLING MAGNATEK HEAD

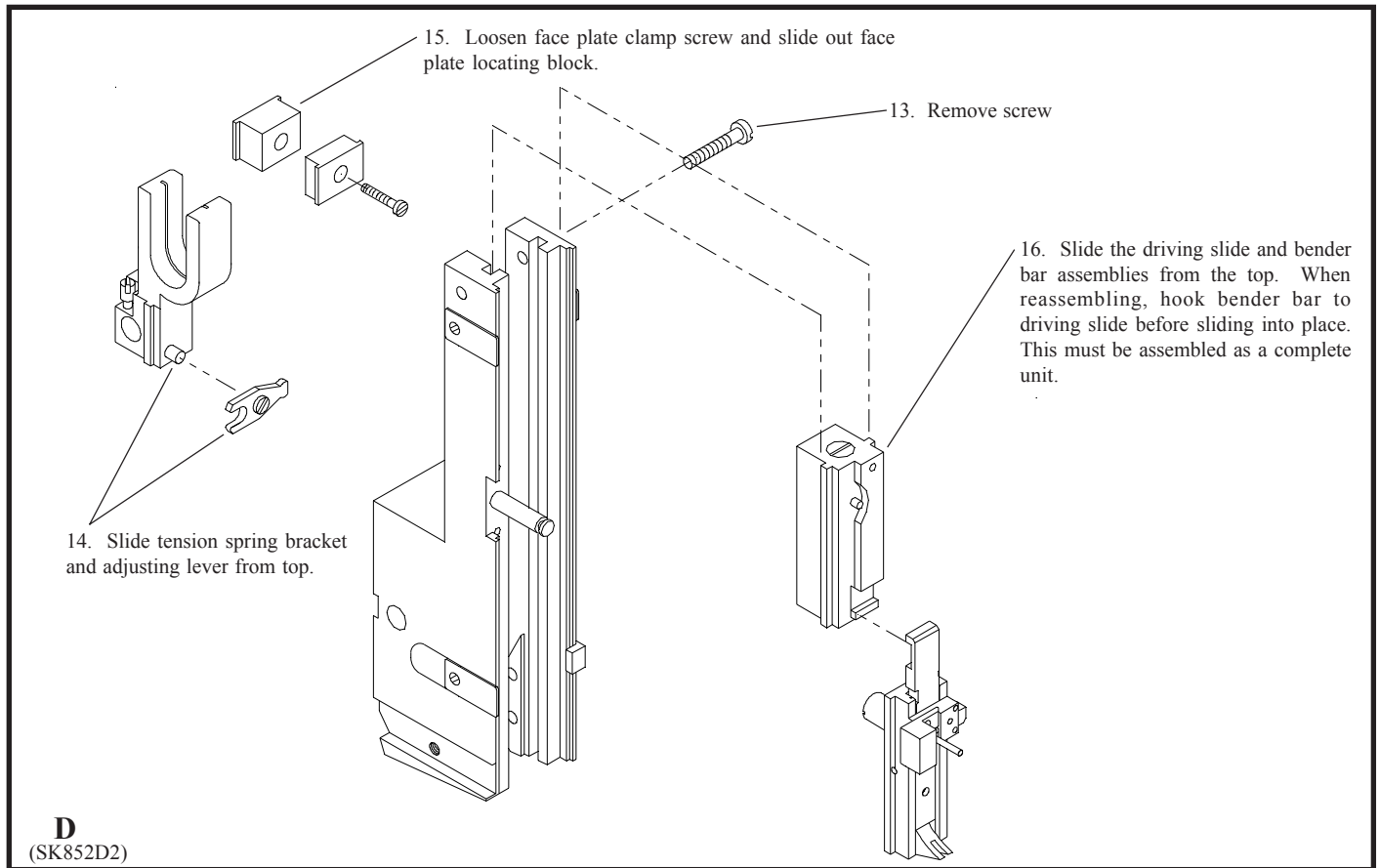

How To Install Swivel Operating Cam

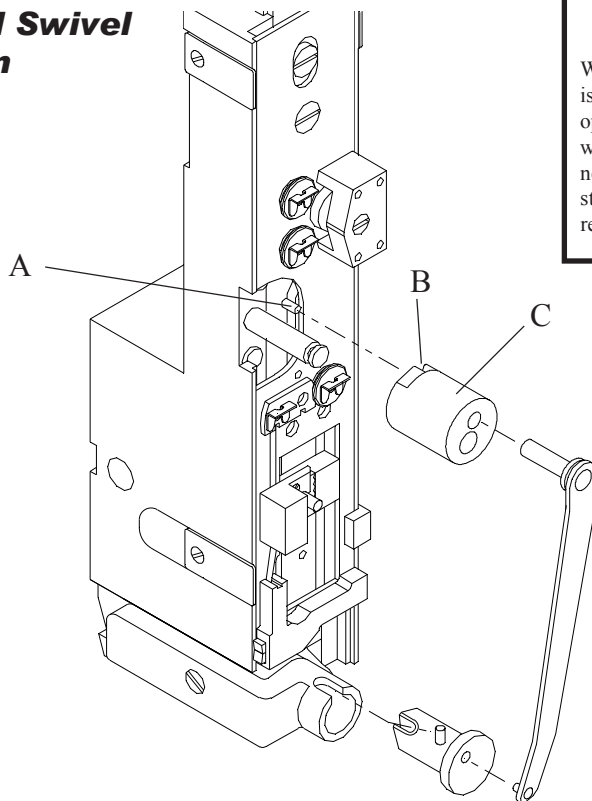

Caution

When reassembling, make certain that pin (Index A) is visible and is aligned with slot (Index B) of rotator operating cam (Index C). If not assembled in this way, the bonnet casting will crack or break on the next cycle under power. It is recommended that the stitcher be turned over by hand to test that proper reassembly procedure has been followed.

E
(SK852E2)

Section 6

PARTS LIST

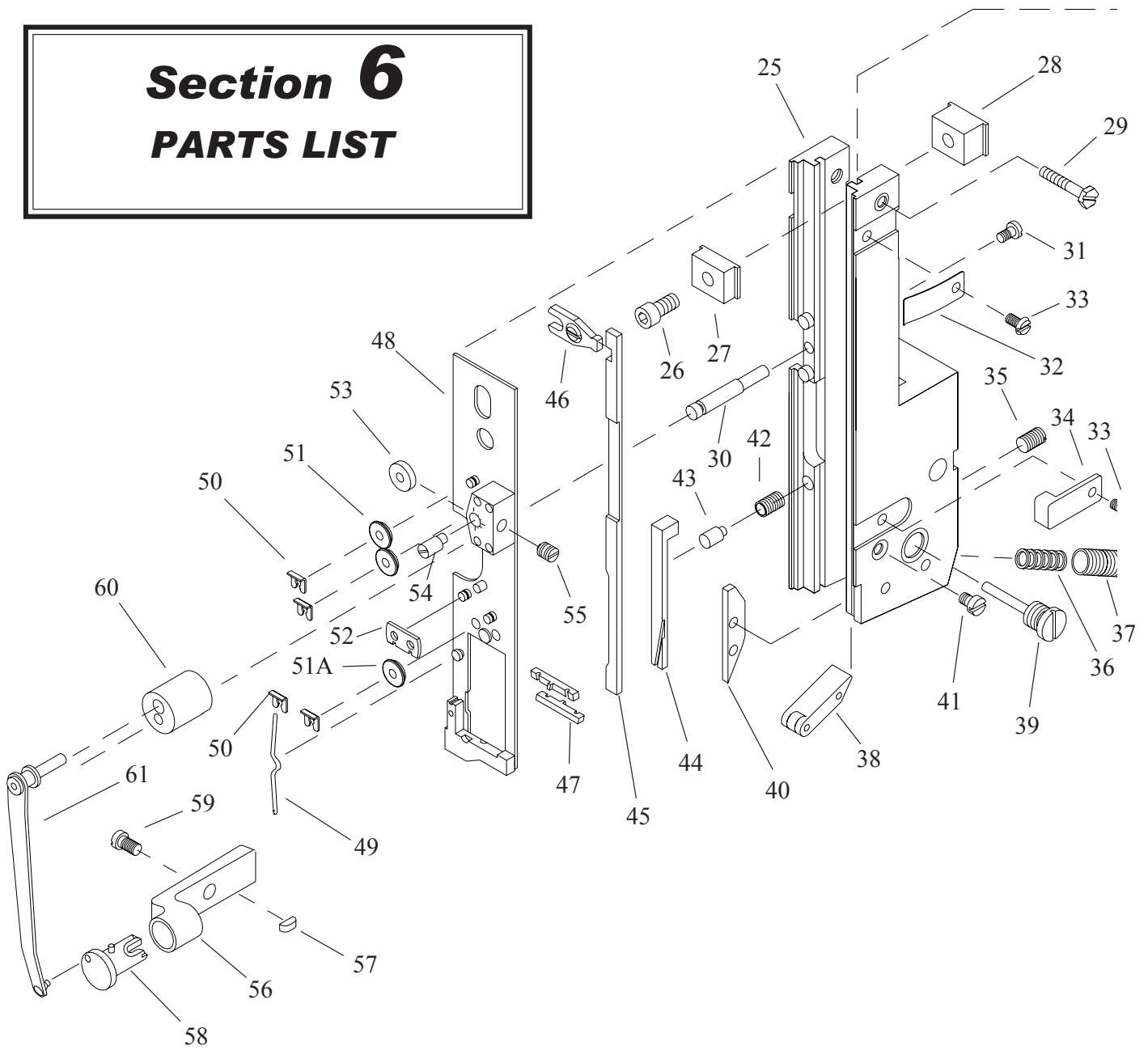
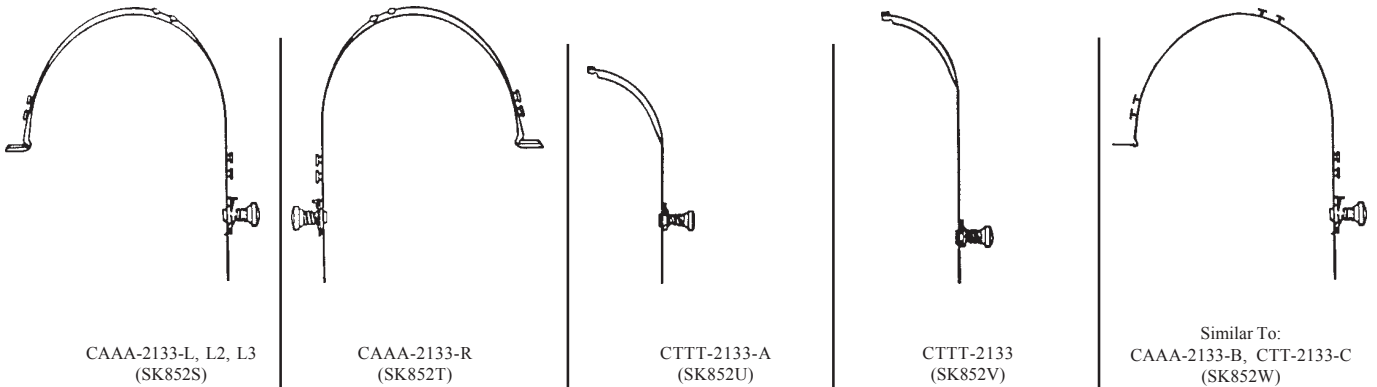

Figure 19
(SK852R)

Wire Guide Springs Figures 20



CAAA-2133-L, L2, L3
(SK852S)

CAAA-2133-R
(SK852T)

CTTT-2133-A
(SK852U)

CTTT-2133
(SK852V)

Similar To:
CAAA-2133-B, CTT-2133-C
(SK852W)

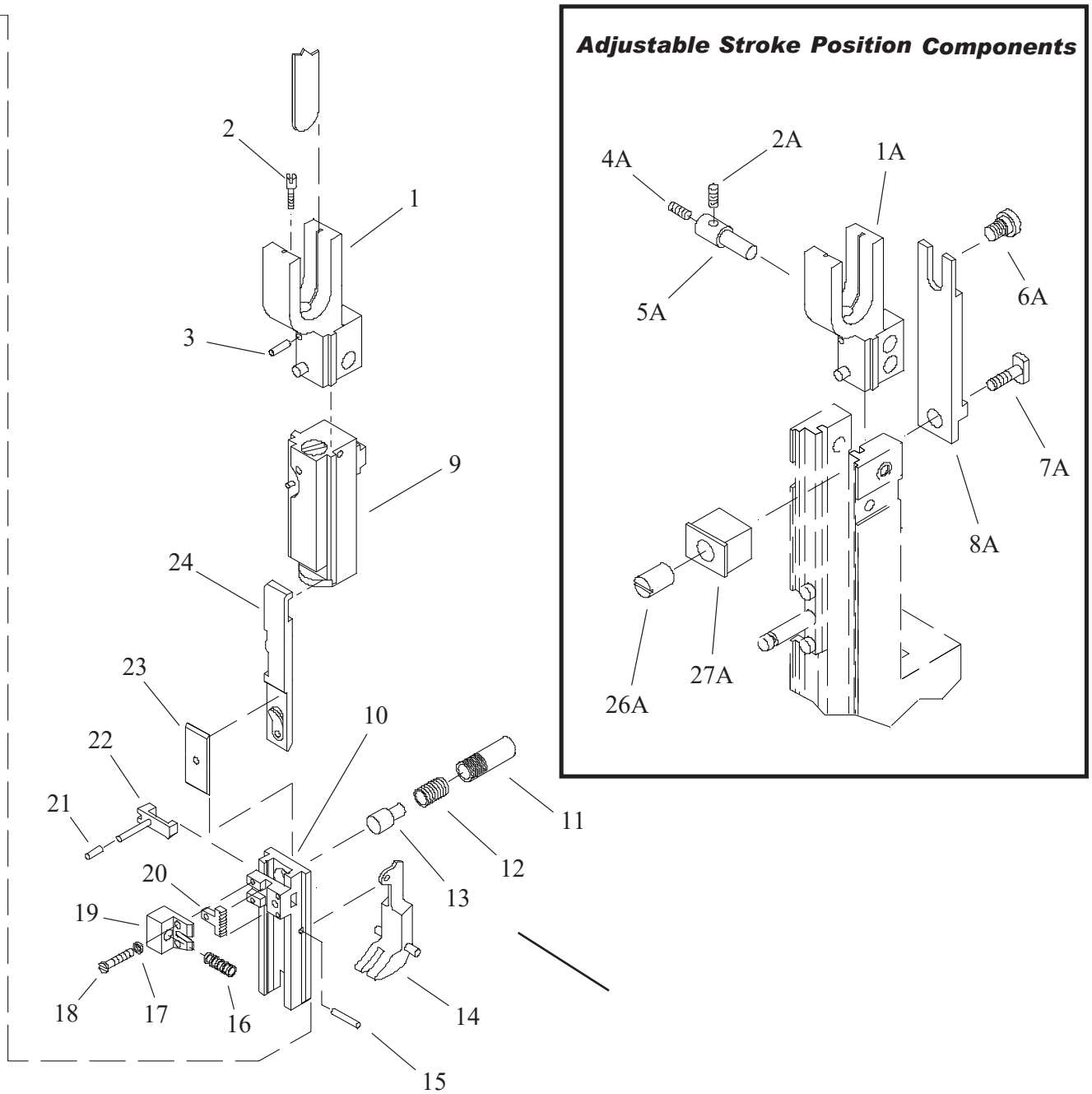

Bolt-On and Clamp-On Heads Figures 21

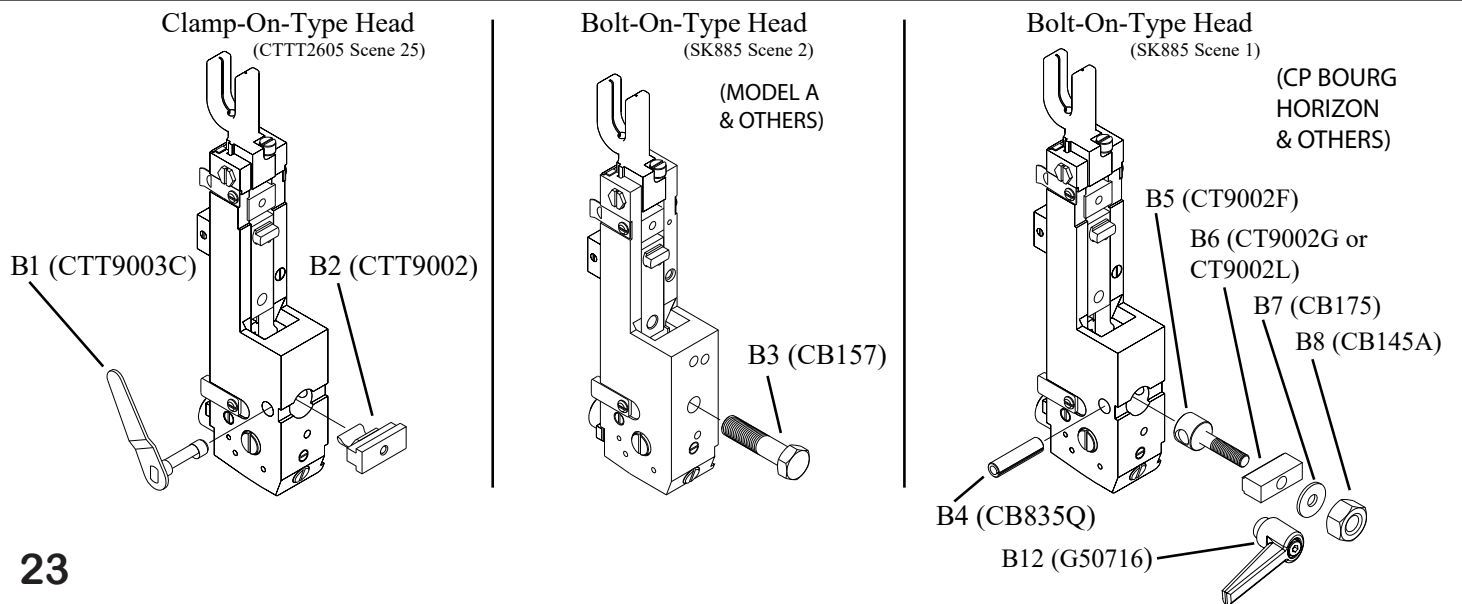

MAGNATEK HEAD

PARTS LIST

ITEM	PART NO.	DESCRIPTION	QTY
1	CAA9074Z	WIRE GUIDE BRACKET ASSEMBLY	1
1A	CTT2615B	WIRE GUIDE BRACKET ASSEMBLY	1
2	CA9076	WIRE GUIDE SPRING BRKT ADJ SCREW	1
2A	CT56	WIRE GUIDE SPRING BRKT ADJ SCREW	1
3	CA9077	WIRE GUIDE SPRING BRKT SET SCREW	1
4A	CT1060	SET SCREW	1
5A	CT2616	WIRE GUIDE BRACKET ADJ. SCREW STUD	1
6A	CT2614	FACE PLATE ADJ. SLIDE GUIDE STUD	1
7A	CT2612	FACE PLATE LOCATING BLOCK STUD	1
8A	CT2610	FACE PLATE ADJUSTING SLIDE	1
9	See TABLE 1	DRIVING SLIDE ASSEMBLY	1
		NOTE: The Driving Slide Assembly includes the following parts:	
		DRIVING SLIDE (ONLY)	1
a,c,d,f		CA-2623 (standard)	
b		CT-2623 (2 sheets to .125 in. thick work)	
e		CA-2623-B (pin holds in driving slide spring)	
		DRIVING SLIDE SPRING PLUNGER	1
a,b,c,d,f		CA-2007	
e		CA-2007-A	
		DRIVING SLIDE SPRING	1
a,b,c,d,f		CA-9006	
e		CA-9006-A	
		DRIVING SLIDE SPRING SCREW	1
a,b,c,d,f		CA-9021-A	
		DRIVING SLIDE SPRING PIN	1
e		D-37327-F	
		DRIVING SLIDE ROTATOR OP. PIN	1
all		CA-9028	
		DRIVING SLIDE SPRING SCREW LOCK PIN	1
a,b,c,d,f		CA-9028-A	
10		BENDER BAR ASSY. COMPLETE	1
a	CAAA9013W	1/2" Cr., 25 to 30 Rd wire	
b	CAAA9013C3	1/2" Cr., 25 to 30 Rd. wire (McCain)	
c	CAAA9013G2	1/2" Cr., 24 Rd. wire	
d	CAAA9013J2	1/2" Cr., 20-21 x 25 wire	
e	CAAA9013Q2	1/2" Cr., 22 Rd. wire	
f	CAAA9513H	3/8" Cr., 25 to 30 Rd. wire	
g	CAAA9513K	3/8" Cr., 20-21x25 wire	
h	CAAA9613C	5/16" Cr., 25 Rd. wire	

ITEM	PART NO.	DESCRIPTION	QTY
		NOTE: The above Bender Bar Assembly includes the following items through item 24	
		BENDER BAR SUB ASSEMBLY	1
a	CAA9013U	1/2" Cr., 25 to 30 rd. wire	
b	CAA9013Z	1/2" Cr., 25 to 30 rd. wire (McCain, Macey)	
c	CAA9013F2	1/2" Cr., 24 rd. wire	
d	CAA9013H2	1/2" Cr., 20-21 x 25 wire	
e	CAA9013K2	1/2" Cr., 24 rd. wire (McCain)	
f	CAA9013P2	1/2" Cr., 22 rd. wire	
g	CAA9513G	3/8" Cr., 25 to 30 rd. wire	
h	CAA9513K	3/8" Cr., 20-21x25 wire	
i	CAA9613C	5/16" Cr., 25 Rd. wire	
11	CA9115	BENDER BAR FRICTION PLUG BUSHING	1
12	CA9113A	BENDER BAR FRICTION PLUG SPRING	1
13	CA9112A	BENDER BAR FRICTION PLUG	1
14		SUPPORTER ASSEMBLY	1
	CAA9026	1/2" Cr.	
	CAA9526	3/8" Cr.	
	CAA9626	5/16" Cr	
15	CA9029	SUPPORTER PIVOT PIN	1
16	CA168	EXTERNAL GRIP SPRING	1
17	CB371K	LOCKWASHER	1
18	CA9024A	GRIP HOUSING RETAINING SCREW	1
19	CT413A	GRIP SPRING HOUSING	1
20	CA9015D	GRIP	1
21	CA173	PLASTIC PIN CAP	1
22		BENDER BAR LATCH	1
	CAA9014E	(All Except McCain)	
	CAA9014F	(McCain)	
23		DRIVER	1
	CA9009	1/2" Cr. 24 to 30 Rd.	
	CA9009C	1/2" Cr. 20x25 & 21x25 wire	
	CA9509	3/8" Cr. 24 to 30 Rd.	
	CA9509F	3/8" Cr. 21x25 wire	
	CA9609	5/16" Cr. 25 Rd. wire	
24		DRIVER BAR ASSEMBLY	1
	CAA9012A	1/2" Cr.	
	CAA9012D	1/2" Cr. (McCain)	
	CAA9512A	3/8" Cr.	
	CAA9612A	5/16" Cr	

TABLE 1

(For use in determining customer's Driving Slide Assembly)

ITEM	PART NO.	DESCRIPTION	Driving Slide Style/Use	Lug Style
9		DRIVING SLIDE ASSEMBLY		
a	CTT2623		standard, raised lug	.187 lg. rectangular (CT2602)
b	CTT2623A		lowered lug for 2 sheets to .125 in. thick work	.187 lg. rectangular (CT2602)
c	CTT2623C		standard, raised lug	.25 lg. rectangular (CT2602A)
d	CAA2623		standard, raised lug	round (CA2103) w/.031 thk. washer (CT32B)
e	CAA2623C		pin (D37327F) holds in driving slide spring	round (CA2103) w/.031 thk. washer (CT32B)
f	CAA2623D		standard, raised lug	round (CA2103B) w/.079 thk. washer
g	CTT2623H		standard, raised lug	.187 lg. rectangular (CT2602)

* Contact **Deluxe Stitcher** customer service for Magnatek heads not listed

MAGNATEK HEAD

PARTS LIST

ITEM	PART NO.	DESCRIPTION	QTY
25		BONNET CASTING SUB ASSEMBLY	1
		<u>*Magnatek Heads that use bonnet sub assembly</u>	
	CAA2004	CAAA2004	
	CAA2004B	CAAA2004J	
	CAA2004E	CAAA2504G,L,R, CAAA2004F,G	
	CTT2604	CTTT2604,A,C,E,F,G,O,U,E2,R2, H3,P3,R3,G4,H4,J4,R10,W3	
	CTT2604A2	CTTT2604A2	
	CTT2604P	CTTT2604P2	
	CTT2604H	CTTT2604M3	
	CTT2604L	CTTT2604Q3	
	CTT2604N	CTTT2604T3,V3	
	CTT2604G	CTTT2604U3	
26	CT2608	FACE PLATE LOCATING BLOCK SCREW	1
26A	CT2613	FACE PLATE LOCATING BLOCK NUT	1
27	CT2606	FACE PLATE LOCATING CLAMP	1
27A	CT2611	FACE PLATE ADJ. SLIDE BLOCK	1
28	CT2607	FACE PLATE LOCATING BLOCK	1
29	CA9075	WIRE GUIDE BRACKET SCREW	1
30	CA9127	ROTATOR OPERATING CAM STUD	1
31	CA9058	ROTATOR OPERATING CAM STUD SCREW	1
32	CA9056C	FACE PLATE RETAINING CLIP	3
33	CA2081	FACE PLATE RETAINING CLIP SCREW	4
34	CA9056A	FACE PLATE RETAINING CLIP	1
35	CT9109	BONNET ALIGNING SCREW 0 to 2 as req'd.	
36	CA9032	SUPPORTER SPRING	1
37	CA9037	SUPPORTER SPRING BUSHING	1
38		SUPPORTER SPRING LEVER ASSEMBLY	1
	CAA9036	Standard (1.625 in. long)	
	CAA9036A	Special (1.494 in. long)	
	CAA9036B	Special (1.312 in. long)	
39	CA9034	SUPPORTER SPRING LEVER SCREW	1
40		SUPPORTER GUIDE PLATE	1
	CA9030	All except listed below. 2 Qty. used on: CAAA2004F,G	
	CA9030A	2 Qty. used on: CTTT2604A2 (McCain)	
41	CA9081	SUPPORTER GUIDE PLATE SCREW	1
42	CA9051A	WIRE CUTTER OPERATING SLIDE	1
		FRICTION PLUG SPRING	
43	CA9050A	WIRE CUTTER OPERATING SLIDE	1
		FRICTION PLUG	
44		WIRE CUTTER OPERATING SLIDE	1
	CA9049	1/2" Cr. (All 1/8", .155", 3/16" capacity heads, and CTTT2604F4,H4 heads.)	
	CA9049A	1/2" Cr. (All other 1/2" Cr Heads not listed above)	
	CA9549	3/8" Cr. 5/16" Cr. Head (8mm)	
45		GRIP RELEASE SLIDE	
	CA9022	1/2" Crown	1
	CA9522	3/8" Crown	1

ITEM	PART NO.	DESCRIPTION	QTY
46		FACE PLATE ADJUSTING LEVER	1
	CA9025	For Non-Slotted Face Plates	
	CA9025D	For Slotted Face Plates	
47	CA9048	WIRE CUTTER	2
48		FACE PLATE ASSEMBLY	1
	CAAA2132H	1/2" Crown, Slotted	
	CAAA2132K	1/2" Crown, No Slot	
	CAAA2132L	1/2" Crown, Fixed (Bypass)	
	CAAA2579C	3/8" Crown, Slotted	
		5/16" Crown Head (8mm)	
	CAAA2579D	3/8" Crown, No Slot	
	NOTE: The above face plate assemblies include indexes 48 to 55		
48		FACE PLATE SUB ASSEMBLY	1
	CAA2132H	1/2" Crown, Slotted	
	CAA2132K	1/2" Crown, No Slot	
	CAA2132L	1/2" Crown, Fixed (By-Pass)	
	CAA2579C	3/8" Crown, Slotted or 5/16 5/16" Crown Head (8mm)	
	CAA2579D	3/8" Crown, No Slot	
49	CA9134	TENSION PAWL SPRING	1
50	CA9124	TENSION ROLL CLIP	4
51	CA9103C	WIRE STRAIGHTENER ROLL	2
51A	CA9103A	CHECK PAWL ROLLER	1
52	CA9098	TENSION PAWL	1
53	CA9065A	STRAIGHTENER ECCENTRIC ROLL	1
54	CA9066A	WIRE STRAIGHTENER ECCENTRIC	1
55	CA172	ECCENTRIC FRICTION LOCKING SCREW	1
56		ROTATOR HOLDER	1
	CA9043H	1/2" CR., 25 TO 30 RD. WIRE, TAPERED END	
	CA9043E	3/8" CR., 25 TO 30 RD. WIRE, R.H. MOUNT	
	CA9543A	3/8" CR., 25 TO 30 RD. WIRE 5/16" Cr. Head (8mm)	
	CA9043A	1/2" CR., 25 TO 30 RD. WIRE	
	CA9043C	1/2" CR., 20-21X25 WIRE	
57	CB75B	KEY, WOODRUFF (for use with CA-9043-H Rotator Holder only)	1
58		MAGNETIC ROTATOR	1
	CAA9038M	1/2" CROWN 5/16" Cr. Head (8mm)	
	CAA9538M	3/8" CROWN	
	CAA9638	5/16" CROWN	
59		ROTATOR HOLDER SCREW	1
	CA9044A	all except below	
	CA9044B	CTTT2604W2,Y2,Z2,A3,X3,R7 CAAA2004K	
60		ROTATOR OPERATING CAM	1
	CA9163C	standard oiling	
	CA9163D	inverted oiling	
61		ROTATOR OPERATING SPRING ASSEMBLY	1
	CAA9046A	5/16" Cr. Head (8mm)	

(For use in determining customer's special components)

ITEM	PART NO.	DESCRIPTION	QTY	USAGE
B1	CTT9003C	BONNET CLAMP LEVER	1	CTTT2605,C,G,R3,F4
B2	CTT9002	BONNET CLAMP ASSEMBLY	1	CTTT2605,C,G,R3,F4
B3	CB157	BONNET BINDER SCREW	1	
B4	CB835Q	ROLL PIN	1	CTTT2605P2,P4,Q3,R2
B5		BONNET BINDER STUD	1	
	CT9002A	.500-13 NC Thread		CTTT2605R2
	CT9002F	M8 X 1.25-8g Thread		CTTT2605P2,P4,Q3
B6		TEE BAR	1	
	CT9002G	.625 Long		CTTT2605P2
	CT9002L	.841 Long		CTTT2605Q3
B7	CB175	WASHER	1	CTTT2605P2,Q3
B8	CB145A	NUT, .500-13 NC	1	CTTT2605R2
B9	CT9109A	BONNET ALIGNMENT PIN	2	CTTT2605Q3
B10	CT9111	CONE POINT SET SCREW	2	CTTT2605Q3
B11	CA44	HEAD OPERATING LINK	1	CTTT2605R2 (For use <u>only</u> with round lug driving slide assemblies)
B12	G50716	MOUNTING BLOCK HANDLE	1	

CLINCHER PLATE ASSEMBLIES

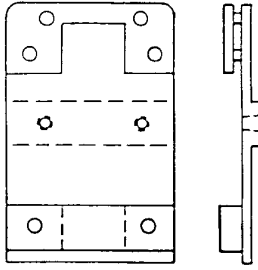

TYPE A
(SK852F2)

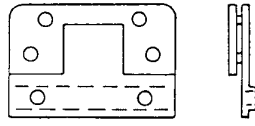

TYPE B
(SK852G2)

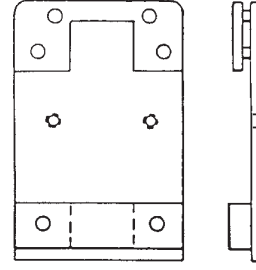

TYPE C
(SK852H2)

CROWN SIZE	CLINCHER POINT	TYPE	CLINCHER PLATE ASSY.
3/8	CA-9583-A Thick	A	CTT-9586-A
3/8	CA-9583-A Thick	C	CAA-2589-B
1/2	CA-9083 Thin	A	CTT-9086
1/2	CA-9083-A Thick	A	CTT9086-A
1/2	CA-9083 Thin	A	CTTT-9086*
1/2	CA-9083-A Thick	A	CTTT9086-A**
1/2	CA-9083 Thin	B	CTT-9086-B
1/2	CA-9083-A Thick	B	CTT9086-F
1/2	CA-9083 Thin	C	CAA-2089
1/2	CA-9083-A Thick	C	CAA-2089-A



CA-2090
STUD

(SK852J2)

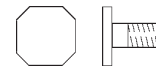

CT-9088
BINDER
BOLT

(SK852K2)

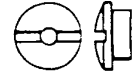

CA-2091
NUT

(SK852L2)

* Includes CA-9083, CTT-9086, CT-9093, CA-2091, CT-9088.
** Includes CA-9083-A, CTT-9086-A, CT-9093-A, CA-2091, CT-9088.

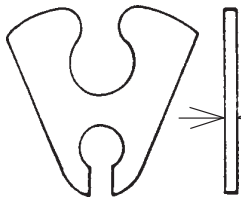

(SK852I2)

CLINCHER POINT

1/16 Nominal, CA-9583-A, Thick, 3/8 Crown
1/16 Nominal, CA-9083-A, Thick, 1/2 Crown
1/32 Nominal, CA-9083, Thin, 1/2 Crown

CLINCHER SLIDES

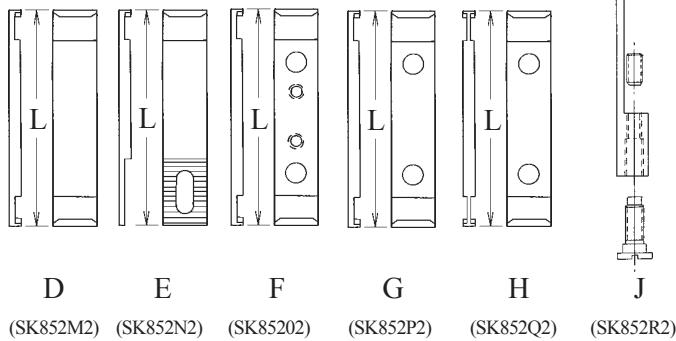

D (SK852M2)
E (SK852N2)
F (SK852O2)
G (SK852P2)
H (SK852Q2)
J (SK852R2)

TYPE	L	CLINCHER SLIDE	CLINCHER POINT
D	3-17/32	CT-9093	Thin
D	3-37/64	CT-9093-A	Thick
E	5-9/16	CT-9093-R	Thin
E	5-9/16	CT-9093-S	Thick
F	3-31/64	CA-2095-G	Thick
G	12-25/32	CA-2095-A	Thick
H	12-25/32	CA-2095	Thin
J	3-17/32 Adjustable	CTT-9093-Y	Thin/Thick

NOTES:

REGISTRATION

To better service your wire stitching needs, please take a moment to fill out and return this registration card.

CUSTOMER

Name: _____ (First) _____ (Middle Initial) _____ (Last)
Company: _____
Street Address: _____
City: _____ State/Province: _____ Zip: _____
Country: _____
Phone: _____ Fax: _____ E-mail: _____

PRODUCT

Machine(s) Purchased: _____
Serial Number(s): _____
With Head(s): _____ (Type/Quantity Purchased)
Serial Number(s): _____
Head(s) Purchased: _____
Serial Number(s): _____

DEALER

Date Received: _____
Dealer Name: _____
Dealer Street Address: _____
City: _____ State/Province: _____ Zip: _____
Country: _____
Dealer Phone: _____

Other Bindery Products Used: _____

Please take a moment to fill out the attached card and mail it to DeLuxe Stitcher Company, Inc. In addition, duplicate the information for your records to assist when making further inquiries.

PRODUCT

Machine(s) Purchased: _____
Serial Number(s): _____
With Head(s): _____ (Type/Quantity Purchased)
Serial Number(s): _____
Head(s) Purchased: _____
Serial Number(s): _____

DE LUXE STITCHER GRAPHIC ARTS REPRESENTATIVE

Date Received: _____
Dealer Name: _____
Dealer Street Address: _____
City: _____ State/Province: _____ Zip: _____
Country: _____
Dealer Phone: _____

Would you like information sent to you about new products that would benefit your company? Yes No

Common Replacement Parts for 1/2" Crown

Below is a list of the most common wear/replacement parts for the G8 Stitcher Head. This guide should help you when ordering replacement parts. If the part you need is not listed below, please refer to the more detailed parts list on pages 38-40 in this manual.

Description	Item Number
Clincher Point - Thick, Round	CA9083A
Latch Release Cam	G20115
Feed Slide Retain Screw Assy	G20122A
Follower Ball Bearing	G20140
Moving Wire Cutter	G20145
Bender Bar Latch	G20149
Bender Bar Latch Spring	G20150
Driver Bar	G20151
Driver, 24W	G20152
Driver Retaining Screw	G20153
Bender Bar Friction Plug	G20159
Bender Bar Friction Spring	G20160B
Wire Holder Retaining Spring Foot	G20184
Feed Gear Friction Strip	G20187
Fixed Wire Cutter	G20200
Wire Hook	G20252
Lever Pivot Pin	G20307

PLACE
STAMP
HERE

DELUXE STITCHER
COMPANY INC.
3747 N. Acorn Lane
Franklin Park, IL 60131U.S.A.
Attn: Customer Service

* You can purchase the G8RPK which includes these and other common replacement parts.

WHEN ORDERING PARTS, PLEASE STATE: QUANTITY REQUIRED, PART NUMBER, PART NAME, WIRE SIZE AND CROWN WIDTH OF YOUR STITCHER.



3747 Acorn Lane • Franklin Park • Illinois 60131
Phone: 847-455-4400 • 800-634-0810
Fax: 847-455-4900 • 800-417-9251
<http://www.deluxestitcher.com>

FORM QF76 06-2019