

 **DELUXE STITCHER**
COMPANY INC.
ISP Stitching & Bindery Products

OWNERS
MANUAL

EZ Thread

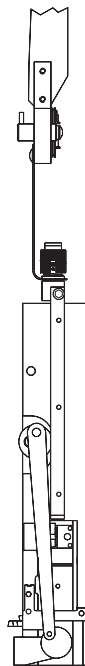

Exclusive Patented
Magnetic Technology

EZ Thread

CONTENTS

Safety	2
Lubrication.....	3
Threading.....	3
Parts: Stitching Head	4
Parts: Face Plate.....	6
Parts: Wire Guide	7

SAFETY

SAFETY PRECAUTIONS AND PROCEDURES

1. *Make sure electrical power is turned off before performing any adjustment or maintenance.*
2. *Keep hands, hair, tools, and clothing clear of stitching area.*
3. *Become familiar with the moving components of your machine. Keep fingers away from areas that could pinch or cut.*
4. *A well maintained machine is a safer machine. Clean and lubricate the machine at regular intervals. Check machine daily for broken or worn parts. Replace as necessary. DO NOT attempt to operate the machine if a part is broken.*
5. *If you are unsure how to safely operate your Bookletmaker, contact your Service Representative.*



KEEP HANDS CLEAR OF STITCHING AREA!

CAUTION

Be sure your stitcher or collator has adequate guards to keep fingers out of the *EZ Thread's* point of operation.

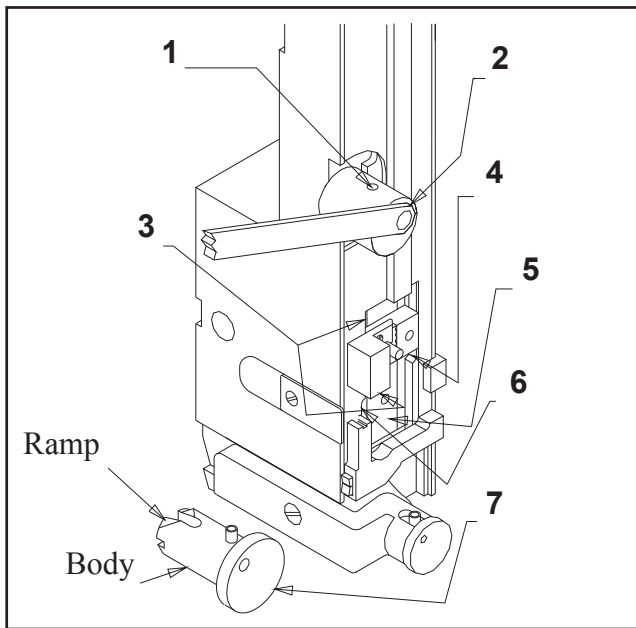

LUBRICATION

Important! The stitching head must be lubricated before each spool of wire (50,000 to 70,000 stitches). Use ISP lubricant #CA9640.

1. Inject lube into hole, or remove and lube shaft.
2. Remove rotator spring and lube shaft.
3. Inject a small amount of lube on cam surface of driver bar above and below grip housing.
4. Wipe area clean, and inject a small amount of lube on grip release cam.
5. Wipe driver clean, and apply a layer of lube.
6. Inject lube into cutter operating slide.
7. Very important! Remove rotator and clean inside of rotator holder. Carefully clean the rotator and apply lube to its body and ramp.

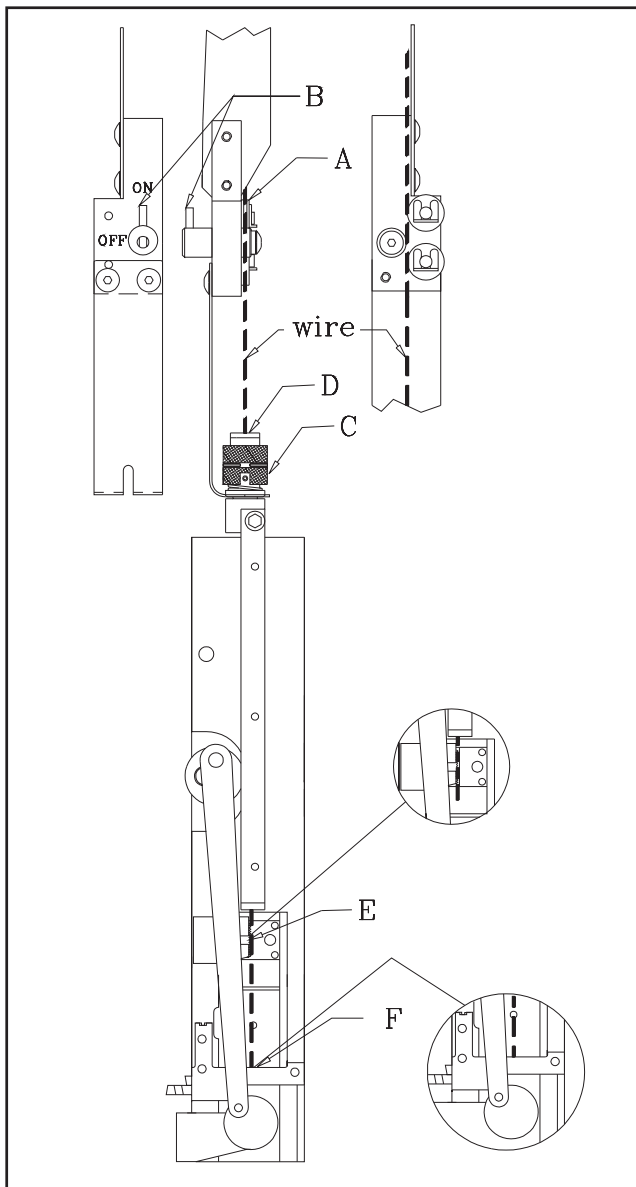

THREADING

1. Rotate the wire threading lever (B) counter clockwise to the "OFF" position.
2. Feed the wire through the rollers on the wire guide as indicated (A).
3. Open the check pawl (D) by pushing downward and turning the collar (C) clockwise until locked.
4. Feed the wire into the funnel at the top of the check pawl (D) until it comes out past the gripper (E).
5. Continue to feed the wire, guiding it into the hole in the top of the cutter (F). Allow the wire to enter this hole about 1/8".
6. Release the collar (C) of the check pawl by rotating counterclockwise until it returns to the upper or unlocked position.
7. Turn wire threading lever (B) clockwise to the "ON" position.

The head is now ready to operate. Please note that two cycles of the newly threaded head will be required before you get a proper stitch.

EZ Thread

STITCHING HEAD ASSEMBLY

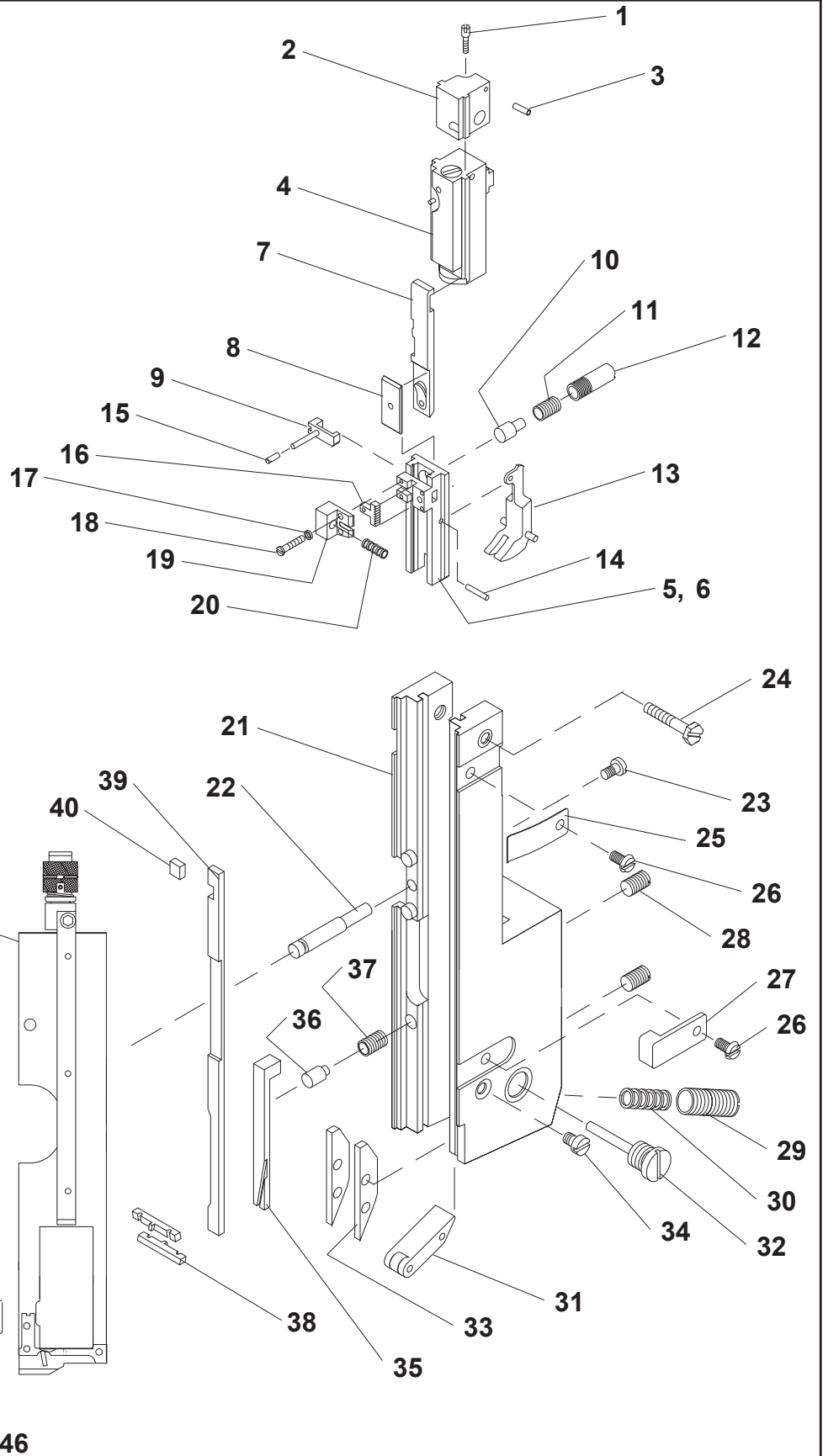

Index Number	Part Number	Part Name	Number Required
1	CA9076	Adjusting Screw	1
2	CA9074C2	Leg Balance Block	1
3	D31028F	Set Screw	1
4	CTT2623	Driving Slide Assy	1
5	CAA9013S2	Bender Bar Assy (Includes Items #6 - #14)	1
6	CAA9013S2	Bender Bar	1
7	CAA9012A	Driver Bar	1
8	CA9009	Driver End	1
9	CAA9014E	Latch Assy	1
10	CA9112A	Friction Plug	1
11	CA9113A	Spring	1
12	CCA9115	Bushing	1
13	CA9026	Supporter	1
14	CA9029	Pivot Pin	1
15	CA173	Black Cap	1
16	CA9015D	Grip	1
17	CB371K	Lockwasher	1
18	CA9024A	Screw	1
19	CT413A	Grip Spring Housing	1
20	CA168	Grip Spring	1
21	CAA2004G	Bonnet Assy (Includes Items #22 & #23)	1
22	CA9127	Cam Stud	1
23	CA9058	Screw	1
24	CA9075	Screw	1
25	CA9056C	Face Plate Clip	3
26	CA2081	Clip Screw	4
27	CA9056A	Face Plate Clip	1
28	CT9109	Bonnet Aligning Screw	2
29	CA9037	Supporter Spring Bushing	1
30	CA9032	Supporter Spring	1
31	CAA9036	Supporter Spring Lever	1
32	CA9034	Supporter Spring Lever Screw	1
33	CA9030	Supporter Guide Plate	2
34	CA9081	Supporter Guide Plate Screw	2
35	CA9049	Cutter Operating Slide	1
36	CA9050A	Friction Plug	1
37	CA9051A	Friction Plug Spring	1
38	CA9048	Wire Cutter	2
39	CA9022G	Grip Release Slide	1
40	CA9025A	Key	1
41	CAA2132R	Face Plate Assy (See next page for details.)	1
42	CA9163C	Rotator Operating Cam	1
43	CAA9046A	Rotator Operating Spring	1
44	CA9043A	Rotator Holder	1
45	CA9044A	Rotator Holder Screw	1
46	CAA9038M	Magnetic Rotator	1

EZ Thread

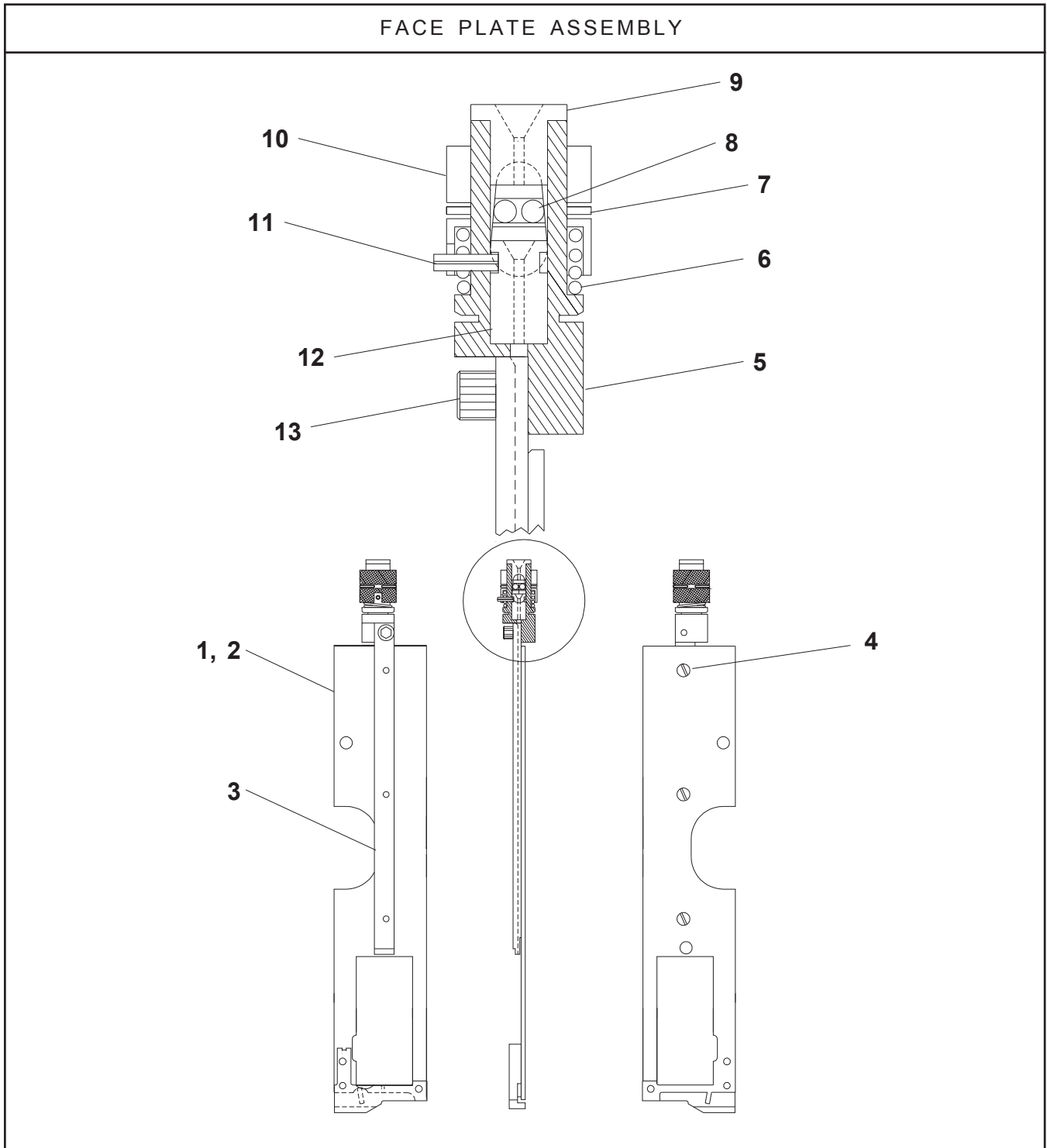

Index Number	Part Number	Part Name	Number Required	Index Number	Part Number	Part Name	Number Required
1	CAAA2132R	Face Plate Assy (Includes Items #2 - #13.)	1	7	CB517	Retaining Ring	1
2	CAA2132R	Face Plate	1	8	CB516	Check Pin	2
3	CA182A	Feed Tube	1	9	CA180	Top Wire Guide Bushing	1
4	CA9643	Flat Head Screw	3	10	CB515B	Check Sleeve	1
5	CB513E	Check Pawl Body	1	11	CB835R2	Roll Pin	1
6	CB337	Spring	1	12	CA181A	Bottom Wire Guide Bushing	1
				13	D30676F	Cap Screw	1

WIRE GUIDE ASSEMBLY

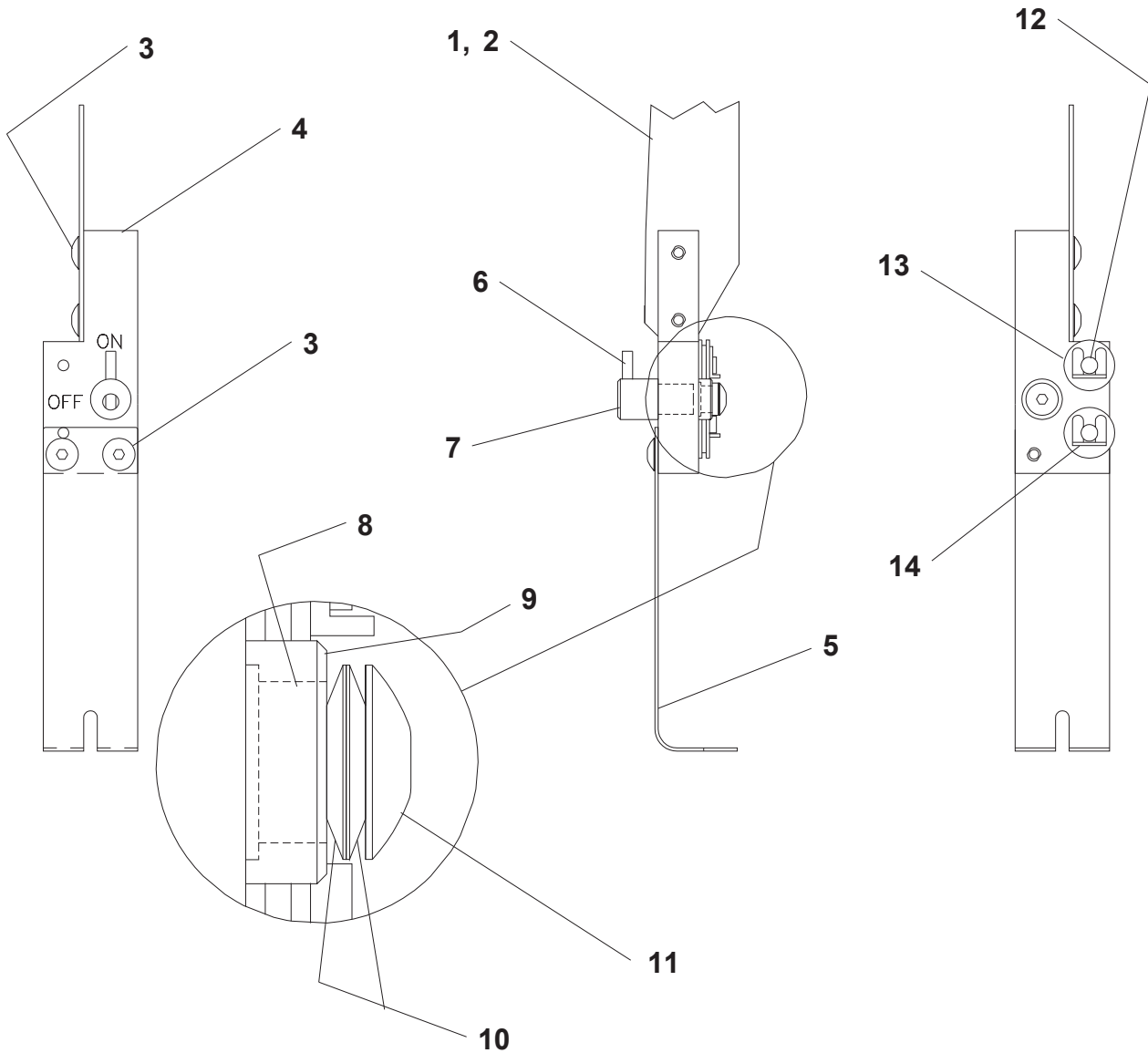

Index Number	Part Number	Part Name	Number Required	Index Number	Part Number	Part Name	Number Required
1	CAAA2133V	Wire Guide Assy (Includes Items #2 - #14.)	1	8	CA9068	Bushing	1
2	CAA2133V	Wire Guide	1	9	CA9065	Roller	1
3	CG26N	Button Head Screw	4	10	CL44A	Spring Washer	2
4	RBM1422F	Straightener Body	1	11	RBM1424F	Button Head Screw	1
5	RBM1421F	Straightener Bracket	1	12	CA9123B	Stud	2
6	D41302F	Roll Pin	1	13	CA9103C	Roll	2
7	RBM1423F	Straightener Eccentric	1	14	CA9124	Clip	2

EZ Thread



6635 West Irving Park Road, Chicago, Illinois 60634-2410

Phone: 773-777-6500 800-634-0810

Fax: 773-777-0156 800-417-9251

E-mail: info@deluxestitcher.com

<http://www.deluxestitcher.com>